

4.23.18 class 25: *Symmetry Principles for Advanced Atomic-Molecular-Optical-Physics*

William G. Harter - University of Arkansas

$(S_3)^*(U(3)) \subset U(6)$ models of p^3 electronic spin-orbit states and couplings

[2,1] tableau states lowered by $L_- = \sqrt{2}(E_{21} + E_{32})$

Top-(J,M) states thru mid-level states

$\ell=1$ p -shell LS states combined to states of definite J

J=3/2 at L=0 (4S). J=5/2 at L=2 (2D)

Clebsch-Gordon coupling; J=3/2 at L=2 (2D)

J=3/2 at L=1 (2P)

J=1/2 at L=1 (2P)

Spin-orbit state assembly formula and Slater determinants

The simplest assembly (Detailed)

$\ell=1$ p -shell LSJ states transformed to Slater determinants from J=3/2 (4S)

Slater functions for J=5/2 (2D)

Slater functions for J=3/2 (2D)

Slater functions for J=3/2 (2P)

Slater functions for J=1/2 (2P)

Application to spin-orbit and entanglement break-up scattering (next class)

AMOP reference links (Updated list given on 2nd and 3rd pages of each class presentation)

[Web Resources - front page](#)

[Quantum Theory for the Computer Age](#)

[2014 AMOP](#)

[UAF Physics UTube channel](#)

[Principles of Symmetry, Dynamics, and Spectroscopy](#)

[2017 Group Theory for QM](#)

[Classical Mechanics with a Bang!](#)

[2018 AMOP](#)

[Modern Physics and its Classical Foundations](#)

[Representations Of Multidimensional Symmetries In Networks - harter-jmp-1973](#)

Alternative Basis for the Theory of Complex Spectra

[Alternative Basis for the Theory of Complex Spectra I - harter-pra-1973](#)

[Alternative Basis for the Theory of Complex Spectra II - harter-patterson-pra-1976](#)

[Alternative Basis for the Theory of Complex Spectra III - patterson-harter-pra-1977](#)

[Frame Transformation Relations And Multipole Transitions In Symmetric Polyatomic Molecules - RMP-1978](#)

[Asymptotic eigensolutions of fourth and sixth rank octahedral tensor operators - Harter-Patterson-JMP-1979](#)

[Rotational energy surfaces and high- J eigenvalue structure of polyatomic molecules - Harter - Patterson - 1984](#)

[Galloping waves and their relativistic properties - ajp-1985-Harter](#)

[Rovibrational Spectral Fine Structure Of Icosahedral Molecules - Cpl 1986 \(Alt Scan\)](#)

Theory of hyperfine and superfine levels in symmetric polyatomic molecules.

I) [Trigonal and tetrahedral molecules: Elementary spin-1/2 cases in vibronic ground states - PRA-1979-Harter-Patterson \(Alt scan\)](#)

II) [Elementary cases in octahedral hexafluoride molecules - Harter-PRA-1981 \(Alt scan\)](#)

Rotation-vibration spectra of icosahedral molecules.

I) [Icosahedral symmetry analysis and fine structure - harter-weeks-jcp-1989 \(Alt scan\)](#)

II) [Icosahedral symmetry, vibrational eigenfrequencies, and normal modes of buckminsterfullerene - weeks-harter-jcp-1989 \(Alt scan\)](#)

III) [Half-integral angular momentum - harter-reimer-jcp-1991](#)

[Rotation-vibration scalar coupling zeta coefficients and spectroscopic band shapes of buckminsterfullerene - Weeks-Harter-CPL-1991 \(Alt scan\)](#)

[Nuclear spin weights and gas phase spectral structure of ¹²C₆₀ and ¹³C₆₀ buckminsterfullerene -Harter-Reimer-Cpl-1992 - \(Alt1, Alt2 Erratum\)](#)

[Gas Phase Level Structure of C₆₀ Buckyball and Derivatives Exhibiting Broken Icosahedral Symmetry - reimer-diss-1996](#)

[Fullerene symmetry reduction and rotational level fine structure/ the Buckyball isotopomer ¹²C ¹³C₅₉ - jcp-Reimer-Harter-1997 \(HiRez\)](#)

[Wave Node Dynamics and Revival Symmetry in Quantum Rotors - harter - jms - 2001](#)

[Molecular Symmetry and Dynamics - Ch32-Springer Handbooks of Atomic, Molecular, and Optical Physics - Harter-2006](#)

Resonance and Revivals

I) [QUANTUM ROTOR AND INFINITE-WELL DYNAMICS - ISMSLi2012 \(Talk\) OSU knowledge Bank](#)

II) [Comparing Half-integer Spin and Integer Spin - Alva-ISMS-Ohio2013-R777 \(Talks\)](#)

III) [Quantum Resonant Beats and Revivals in the Morse Oscillators and Rotors - \(2013-Li-Diss\)](#)

[Resonance and Revivals in Quantum Rotors - Comparing Half-integer Spin and Integer Spin - Alva-ISMS-Ohio2013-R777 \(Talk\)](#)

[Molecular Eigensolution Symmetry Analysis and Fine Structure - IJMS-harter-mitchell-2013](#)

[Quantum Revivals of Morse Oscillators and Farey-Ford Geometry - Li-Harter-cpl-2013](#)

[QTCA Unit 10 Ch 30 - 2013](#)

[AMOP Ch 0 Space-Time Symmetry - 2019](#)

**In development - a web based A.M.O.P. oriented reference page, with thumbnail/previews, greater control over the information display, and eventually full on Apache-SOLR Index and search for nuanced, whole-site content/metadata level searching.*

AMOP reference links (Updated list given on 2nd and 3rd pages of each class presentation)

(Int.J.Mol.Sci, 14, 714(2013) p.755-774 ,

QTCA Unit 7 Ch. 23-26),

(PSDS - Ch. 5, 7)

[Int.J.Mol.Sci, 14, 714\(2013\),](#)

[QTCA Unit 8 Ch. 23-25,](#)

[QTCA Unit 9 Ch. 26,](#)

[PSDS Ch. 5,](#)

[PSDS Ch. 7](#)

Intro spin ½ coupling

[Unit 8 Ch. 24 p3](#)

Irrep Tensor building

[Unit 8 Ch. 25 p5.](#)

Intro 3-particle coupling.

[Unit 8 Ch. 25 p28.](#)

H atom hyperfine-B-level crossing

[Unit 8 Ch. 24 p15](#)

Irrep Tensor Tables

[Unit 8 Ch. 25 p12.](#)

Intro 3,4-particle Young Tableaus

[GrpThLect29 p42.](#)

Hyperf. theory [Ch. 24 p48.](#)

Hyperf. theory Ch. 24 p48.

[Deeper theory ends p53](#)

Wigner-Eckart tensor Theorem.

[Unit 8 Ch. 25 p17.](#)

Young Tableau Magic Formulae

[GrpThLect29 p46-48.](#)

Intro 2p3p coupling

[Unit 8 Ch. 24 p17.](#)

Tensors Applied to d,f-levels.

[Unit 8 Ch. 25 p21.](#)

Intro LS-jj coupling

[Unit 8 Ch. 24 p22.](#)

CG coupling derived (start)

[Unit 8 Ch. 24 p39.](#)

Tensors Applied to high J levels.

[Unit 8 Ch. 25 p63.](#)

CG coupling derived (formula)

[Unit 8 Ch. 24 p44.](#)

Lande' g-factor

[Unit 8 Ch. 24 p26.](#)

AMOP reference links (Updated list given on 2nd and 3rd and 4th pages of each class presentation)

Predrag Cvitanovic's: Birdtrack Notation, Calculations, and Simplification

[Chaos Classical and Quantum - 2018-Cvitanovic-ChaosBook](#)
[Group Theory - PUP Lucy Day - Diagrammatic notation - Ch4](#)
[Simplification Rules for Birdtrack Operators - Alcock-Zeilinger-Weigert-zeilinger-jmp-2017](#)
[Group Theory - Birdtracks Lies and Exceptional Groups - Cvitanovic-2011](#)
[Simplification rules for birdtrack operators- jmp-alcock-zeilinger-2017](#)
[Birdtracks for SU\(N\) - 2017-Keppeler](#)

Frank Rioux's: UMA method of vibrational induction

[Quantum Mechanics Group Theory and C60 - Frank Rioux - Department of Chemistry Saint Johns U](#)
[Symmetry Analysis for H2O- H2OGrpTheory- Rioux](#)
[Quantum Mechanics-Group Theory and C60 - JChemEd-Rioux-1994](#)
[Group Theory Problems- Rioux- SymmetryProblemsX](#)
[Comment on the Vibrational Analysis for C60 and Other Fullerenes Rioux-RSP](#)

Supplemental AMOP Techniques & Experiment

[Many Correlation Tables are Molien Sequences - Klee \(Draft 2016\)](#)
[High-resolution spectroscopy and global analysis of CF4 rovibrational bands to model its atmospheric absorption- carlos-Boudon-iqsrt-2017](#)
[Symmetry and Chirality - Continuous Measures - Avnir](#)

*

Special Topics & Colloquial References

[r-process nucleosynthesis from matter ejected in binary neutron star mergers-PhysRevD-Bovard-2017](#)

$\begin{array}{|c|c|} \hline \square & \square \\ \hline \end{array} = [2,1]$ tableau states lowered by $L_- = \sqrt{2}(E_{21} + E_{32})$

	$M=2$	$M=1$	$M=0$	$M=-1$	$M=-2$			
E_{jk}	$\begin{array}{ c } \hline 11 \\ \hline 2 \end{array}$	$\begin{array}{ c } \hline 12 \\ \hline 2 \end{array}$	$\begin{array}{ c } \hline 11 \\ \hline 3 \end{array}$	$\begin{array}{ c } \hline 12 \\ \hline 3 \end{array}$	$\begin{array}{ c } \hline 13 \\ \hline 2 \end{array}$			
$\langle \begin{array}{ c } \hline 11 \\ \hline 2 \end{array} $	$\begin{array}{cc} (11) & (22) \\ 2 & +1 \end{array}$	$\begin{array}{cc} (12) & (23) \\ 1 & 1 \end{array}$	$\begin{array}{cc} (13) \\ -\sqrt{\frac{1}{2}} \end{array}$	$\begin{array}{cc} (13) \\ \sqrt{\frac{3}{2}} \end{array}$	\cdot			
$\langle \begin{array}{ c } \hline 12 \\ \hline 2 \end{array} $	$\begin{array}{cc} (21) \\ 1 \end{array}$	$\begin{array}{cc} (11) & (22) \\ 1 & +2 \end{array}$	$\begin{array}{cc} (23) \\ \sqrt{\frac{1}{2}} \end{array}$	$\begin{array}{cc} (23) \\ \sqrt{\frac{3}{2}} \end{array}$	$\begin{array}{cc} (13) \\ -1 \end{array}$			
$\langle \begin{array}{ c } \hline 11 \\ \hline 3 \end{array} $	$\begin{array}{cc} (32) \\ 1 \end{array}$	\cdot	$\begin{array}{cc} (11) & (33) \\ 2 & +1 \end{array}$	$\begin{array}{cc} (12) \\ \sqrt{2} \end{array}$	$\begin{array}{cc} (13) \\ 1 \end{array}$			
$\langle \begin{array}{ c } \hline 12 \\ \hline 3 \end{array} $	$\begin{array}{cc} (31) \\ -\sqrt{\frac{1}{2}} \end{array}$	$\begin{array}{cc} (32) \\ \sqrt{\frac{1}{2}} \end{array}$	$\begin{array}{cc} (21) \\ \sqrt{2} \end{array}$	$\begin{array}{ccc} (11) & (22) & (33) \\ 1 & +1 & +1 \end{array}$	$\begin{array}{cc} (23) \\ \sqrt{\frac{1}{2}} \end{array}$	$\begin{array}{cc} (12) \\ \sqrt{2} \end{array}$	$\begin{array}{cc} (13) \\ \sqrt{\frac{1}{2}} \end{array}$	
$\langle \begin{array}{ c } \hline 13 \\ \hline 2 \end{array} $	$\begin{array}{cc} (31) \\ \sqrt{\frac{3}{2}} \end{array}$	$\begin{array}{cc} (32) \\ \sqrt{\frac{3}{2}} \end{array}$	\cdot	$\begin{array}{ccc} (11) & (22) & (33) \\ 1 & +1 & +1 \end{array}$	$\begin{array}{cc} (23) \\ \sqrt{\frac{3}{2}} \end{array}$	\cdot	$\begin{array}{cc} (13) \\ \sqrt{\frac{3}{2}} \end{array}$	
$\langle \begin{array}{ c } \hline 13 \\ \hline 3 \end{array} $	\cdot	\cdot	$\begin{array}{cc} (31) \\ 1 \end{array}$	$\begin{array}{cc} (32) \\ \sqrt{\frac{1}{2}} \end{array}$	$\begin{array}{cc} (32) \\ \sqrt{\frac{3}{2}} \end{array}$	$\begin{array}{cc} (11) & (33) \\ 1 & +2 \end{array}$	\cdot	$\begin{array}{cc} (12) \\ 1 \end{array}$
$\langle \begin{array}{ c } \hline 22 \\ \hline 3 \end{array} $	\cdot	$\begin{array}{cc} (31) \\ -1 \end{array}$	\cdot	$\begin{array}{cc} (21) \\ \sqrt{2} \end{array}$	\cdot	$\begin{array}{cc} (22) & (33) \\ 2 & +1 \end{array}$	$\begin{array}{cc} (23) \\ 1 \end{array}$	\cdot
$\langle \begin{array}{ c } \hline 23 \\ \hline 3 \end{array} $	\cdot	\cdot	\cdot	$\begin{array}{cc} (31) \\ \sqrt{\frac{1}{2}} \end{array}$	$\begin{array}{cc} (31) \\ \sqrt{\frac{3}{2}} \end{array}$	$\begin{array}{cc} (21) & (32) \\ 1 & 1 \end{array}$	$\begin{array}{cc} (22) & (33) \\ 1 & +2 \end{array}$	\cdot

$L_z \equiv \begin{pmatrix} 1 & \cdot & \cdot \\ \cdot & 0 & \cdot \\ \cdot & \cdot & -1 \end{pmatrix} = (E_{11} - E_{33}) = \sqrt{2} \mathbf{v}_0^1$ dipole ($k=1$)
 \angle -momentum
L-operators

E_{jk} -matrix
 Lect. 23
 p. 7-16
 and p. 74

$L_+ \equiv \sqrt{2} \begin{pmatrix} \cdot & 1 & \cdot \\ \cdot & \cdot & 1 \\ \cdot & \cdot & \cdot \end{pmatrix} = \sqrt{2}(E_{12} + E_{23}) = L_x + iL_y = -\sqrt{2} \mathbf{v}_1^1$

$L_- \equiv \sqrt{2} \begin{pmatrix} \cdot & \cdot & \cdot \\ 1 & \cdot & \cdot \\ \cdot & 1 & \cdot \end{pmatrix} = \sqrt{2}(E_{21} + E_{32}) = L_x - iL_y = \sqrt{2} \mathbf{v}_{-1}^1$

$L_- \begin{array}{|c|} \hline L \\ \hline M \end{array} \rangle = \sqrt{(L+M)(L-M+1)} \begin{array}{|c|} \hline L \\ \hline M-1 \end{array} \rangle$
 $L_- \begin{array}{|c|} \hline 2 \\ \hline 2 \end{array} \rangle = \sqrt{(2+2)(2-2+1)} \begin{array}{|c|} \hline 2 \\ \hline 1 \end{array} \rangle = 2 \begin{array}{|c|} \hline 2 \\ \hline 1 \end{array} \rangle$

Start with top $[2,1]$ -state:
 $\begin{array}{|c|} \hline 2 \\ \hline 2 \end{array} \rangle = \begin{array}{|c|c|} \hline \square & \square \\ \hline \square \\ \hline \end{array} \rangle = \begin{array}{|c|} \hline 2 \\ \hline D_{M=2} \end{array} \rangle$

$\begin{array}{|c|c|} \hline \square & \square \\ \hline \square & \square \\ \hline \end{array} = [2,1]$ tableau states lowered by $L_- = \sqrt{2}(E_{21} + E_{32})$

E_{jk}	$M=2$	$M=1$	$M=0$	$M=-1$	$M=-2$
$\begin{array}{ c } \hline \langle 11 \\ \hline \end{array}$	$\begin{array}{ c } \hline \langle 11 \\ \hline \end{array}$	$\begin{array}{ c } \hline \langle 12 \\ \hline \end{array}$	$\begin{array}{ c } \hline \langle 11 \\ \hline \end{array}$	$\begin{array}{ c } \hline \langle 12 \\ \hline \end{array}$	$\begin{array}{ c } \hline \langle 13 \\ \hline \end{array}$
$\begin{array}{ c } \hline \langle 12 \\ \hline \end{array}$	$\begin{array}{ c } \hline \langle 12 \\ \hline \end{array}$	$\begin{array}{ c } \hline \langle 11 \\ \hline \end{array}$	$\begin{array}{ c } \hline \langle 11 \\ \hline \end{array}$	$\begin{array}{ c } \hline \langle 12 \\ \hline \end{array}$	$\begin{array}{ c } \hline \langle 13 \\ \hline \end{array}$
$\begin{array}{ c } \hline \langle 11 \\ \hline \end{array}$	$\begin{array}{ c } \hline \langle 11 \\ \hline \end{array}$	$\begin{array}{ c } \hline \langle 11 \\ \hline \end{array}$	$\begin{array}{ c } \hline \langle 11 \\ \hline \end{array}$	$\begin{array}{ c } \hline \langle 12 \\ \hline \end{array}$	$\begin{array}{ c } \hline \langle 13 \\ \hline \end{array}$
$\begin{array}{ c } \hline \langle 12 \\ \hline \end{array}$	$\begin{array}{ c } \hline \langle 12 \\ \hline \end{array}$	$\begin{array}{ c } \hline \langle 12 \\ \hline \end{array}$	$\begin{array}{ c } \hline \langle 12 \\ \hline \end{array}$	$\begin{array}{ c } \hline \langle 12 \\ \hline \end{array}$	$\begin{array}{ c } \hline \langle 12 \\ \hline \end{array}$
$\begin{array}{ c } \hline \langle 13 \\ \hline \end{array}$	$\begin{array}{ c } \hline \langle 13 \\ \hline \end{array}$	$\begin{array}{ c } \hline \langle 13 \\ \hline \end{array}$	$\begin{array}{ c } \hline \langle 13 \\ \hline \end{array}$	$\begin{array}{ c } \hline \langle 13 \\ \hline \end{array}$	$\begin{array}{ c } \hline \langle 13 \\ \hline \end{array}$
$\begin{array}{ c } \hline \langle 22 \\ \hline \end{array}$	$\begin{array}{ c } \hline \langle 22 \\ \hline \end{array}$	$\begin{array}{ c } \hline \langle 22 \\ \hline \end{array}$	$\begin{array}{ c } \hline \langle 22 \\ \hline \end{array}$	$\begin{array}{ c } \hline \langle 22 \\ \hline \end{array}$	$\begin{array}{ c } \hline \langle 22 \\ \hline \end{array}$
$\begin{array}{ c } \hline \langle 23 \\ \hline \end{array}$	$\begin{array}{ c } \hline \langle 23 \\ \hline \end{array}$	$\begin{array}{ c } \hline \langle 23 \\ \hline \end{array}$	$\begin{array}{ c } \hline \langle 23 \\ \hline \end{array}$	$\begin{array}{ c } \hline \langle 23 \\ \hline \end{array}$	$\begin{array}{ c } \hline \langle 23 \\ \hline \end{array}$

E_{jk} -matrix
Lect. 23
p. 7-16
and p. 74

$L_z \equiv \begin{pmatrix} 1 & \cdot & \cdot \\ \cdot & 0 & \cdot \\ \cdot & \cdot & -1 \end{pmatrix} = (E_{11} - E_{33}) = \sqrt{2} \mathbf{v}_0^1$ dipole ($k=1$)
 \angle -momentum
 L -operators

$L_+ \equiv \sqrt{2} \begin{pmatrix} \cdot & 1 & \cdot \\ \cdot & \cdot & 1 \\ \cdot & \cdot & \cdot \end{pmatrix} = \sqrt{2}(E_{12} + E_{23}) = L_x + iL_y = -\sqrt{2} \mathbf{v}_1^1$

$L_- \equiv \sqrt{2} \begin{pmatrix} \cdot & \cdot & \cdot \\ 1 & \cdot & \cdot \\ \cdot & 1 & \cdot \end{pmatrix} = \sqrt{2}(E_{21} + E_{32}) = L_x - iL_y = \sqrt{2} \mathbf{v}_{=1}^1$

$L_- \begin{array}{|c|} \hline \langle L \\ \hline \end{array} \begin{array}{|c|} \hline M \\ \hline \end{array} \rangle = \sqrt{(L+M)(L-M+1)} \begin{array}{|c|} \hline \langle L \\ \hline \end{array} \begin{array}{|c|} \hline M-1 \\ \hline \end{array} \rangle$

$L_- \begin{array}{|c|} \hline \langle 2 \\ \hline \end{array} \begin{array}{|c|} \hline 2 \\ \hline \end{array} \rangle = \sqrt{(2+2)(2-2+1)} \begin{array}{|c|} \hline \langle 2 \\ \hline \end{array} \begin{array}{|c|} \hline 1 \\ \hline \end{array} \rangle = 2 \begin{array}{|c|} \hline \langle 2 \\ \hline \end{array} \begin{array}{|c|} \hline 1 \\ \hline \end{array} \rangle$

$\begin{array}{|c|} \hline \langle 2 \\ \hline \end{array} \begin{array}{|c|} \hline 1 \\ \hline \end{array} \rangle = \frac{1}{2} L_- \begin{array}{|c|} \hline \langle 2 \\ \hline \end{array} \begin{array}{|c|} \hline 2 \\ \hline \end{array} \rangle = \frac{1}{2} \sqrt{2} (E_{21} + E_{32}) \begin{array}{|c|} \hline \langle 11 \\ \hline \end{array} \begin{array}{|c|} \hline 2 \\ \hline \end{array} \rangle = \frac{1}{\sqrt{2}} \begin{array}{|c|} \hline \langle 11 \\ \hline \end{array} \begin{array}{|c|} \hline 2 \\ \hline \end{array} \rangle + \frac{1}{\sqrt{2}} \begin{array}{|c|} \hline \langle 11 \\ \hline \end{array} \begin{array}{|c|} \hline 3 \\ \hline \end{array} \rangle = \begin{array}{|c|} \hline \langle 2 \\ \hline \end{array} \begin{array}{|c|} \hline 1 \\ \hline \end{array} \rangle$

Start with top $[2,1]$ -state:

$\begin{array}{|c|} \hline \langle 2 \\ \hline \end{array} \begin{array}{|c|} \hline 2 \\ \hline \end{array} \rangle = \begin{array}{|c|} \hline \langle 11 \\ \hline \end{array} \begin{array}{|c|} \hline 2 \\ \hline \end{array} \rangle = \begin{array}{|c|} \hline \langle 2 \\ \hline \end{array} \begin{array}{|c|} \hline D_{M=2} \\ \hline \end{array} \rangle$

$\square\square = [2,1]$ tableau states lowered by $L_- = \sqrt{2}(E_{21} + E_{32})$

	$M=2$	$M=1$	$M=0$	$M=-1$	$M=-2$	
E_{jk}	$\begin{matrix} 11\rangle \\ 2 \end{matrix}$	$\begin{matrix} 12\rangle \\ 2 \end{matrix}$ $\begin{matrix} 11\rangle \\ 3 \end{matrix}$	$\begin{matrix} 12\rangle \\ 3 \end{matrix}$ $\begin{matrix} 13\rangle \\ 2 \end{matrix}$	$\begin{matrix} 13\rangle \\ 3 \end{matrix}$ $\begin{matrix} 22\rangle \\ 3 \end{matrix}$	$\begin{matrix} 23\rangle \\ 3 \end{matrix}$	
$\langle 11 $	$\begin{matrix} (11) & (22) \\ 2 & +1 \end{matrix}$	$\begin{matrix} (12) & (23) \\ 1 & 1 \end{matrix}$	$\begin{matrix} (13) \\ -\sqrt{\frac{1}{2}} \end{matrix}$ $\begin{matrix} (13) \\ \sqrt{\frac{3}{2}} \end{matrix}$	\cdot \cdot	\cdot	
$\langle 12 $	$\begin{matrix} (21) \\ 1 \end{matrix}$	$\begin{matrix} (11) & (22) \\ 1 & +2 \end{matrix}$	$\begin{matrix} (23) \\ \sqrt{\frac{1}{2}} \end{matrix}$ $\begin{matrix} (23) \\ \sqrt{\frac{3}{2}} \end{matrix}$	\cdot $\begin{matrix} (13) \\ -1 \end{matrix}$	\cdot	
$\langle 11 $	$\begin{matrix} (32) \\ 1 \end{matrix}$	\cdot	$\begin{matrix} (11) & (33) \\ 2 & +1 \end{matrix}$	$\begin{matrix} (12) \\ \sqrt{2} \end{matrix}$	$\begin{matrix} (13) \\ 1 \end{matrix}$ \cdot	\cdot
$\langle 12 $	$\begin{matrix} (31) \\ -\sqrt{\frac{1}{2}} \end{matrix}$	$\begin{matrix} (32) \\ \sqrt{\frac{1}{2}} \end{matrix}$ $\begin{matrix} (21) \\ \sqrt{2} \end{matrix}$	$\begin{matrix} (11) & (22) & (33) \\ 1 & +1 & +1 \end{matrix}$	\cdot	$\begin{matrix} (23) \\ \sqrt{\frac{1}{2}} \end{matrix}$ $\begin{matrix} (12) \\ \sqrt{2} \end{matrix}$	$\begin{matrix} (13) \\ \sqrt{\frac{1}{2}} \end{matrix}$
$\langle 13 $	$\begin{matrix} (31) \\ \sqrt{\frac{3}{2}} \end{matrix}$	$\begin{matrix} (32) \\ \sqrt{\frac{3}{2}} \end{matrix}$	\cdot	$\begin{matrix} (11) & (22) & (33) \\ 1 & +1 & +1 \end{matrix}$	$\begin{matrix} (23) \\ \sqrt{\frac{3}{2}} \end{matrix}$	$\begin{matrix} (13) \\ \sqrt{\frac{3}{2}} \end{matrix}$
$\langle 13 $	\cdot	\cdot	$\begin{matrix} (31) \\ 1 \end{matrix}$	$\begin{matrix} (32) \\ \sqrt{\frac{1}{2}} \end{matrix}$ $\begin{matrix} (32) \\ \sqrt{\frac{3}{2}} \end{matrix}$	$\begin{matrix} (11) & (33) \\ 1 & +2 \end{matrix}$	$\begin{matrix} (12) \\ 1 \end{matrix}$
$\langle 22 $	\cdot	$\begin{matrix} (31) \\ -1 \end{matrix}$	\cdot	$\begin{matrix} (21) \\ \sqrt{2} \end{matrix}$	\cdot $\begin{matrix} (22) & (33) \\ 2 & +1 \end{matrix}$	$\begin{matrix} (23) \\ 1 \end{matrix}$
$\langle 23 $	\cdot	\cdot	\cdot	$\begin{matrix} (31) \\ \sqrt{\frac{1}{2}} \end{matrix}$ $\begin{matrix} (31) \\ \sqrt{\frac{3}{2}} \end{matrix}$	$\begin{matrix} (21) & (32) \\ 1 & 1 \end{matrix}$	$\begin{matrix} (22) & (33) \\ 1 & +2 \end{matrix}$

E_{jk} -matrix
Lect. 23
p. 7-16
and p. 74

$$L_z \equiv \begin{pmatrix} 1 & \cdot & \cdot \\ \cdot & 0 & \cdot \\ \cdot & \cdot & -1 \end{pmatrix} = (E_{11} - E_{33}) = \sqrt{2} \mathbf{v}_0^1 \text{ dipole } (k=1) \text{ } \angle\text{-momentum } \mathbf{L}\text{-operators}$$

$$L_+ \equiv \sqrt{2} \begin{pmatrix} \cdot & 1 & \cdot \\ \cdot & \cdot & 1 \\ \cdot & \cdot & \cdot \end{pmatrix} = \sqrt{2}(E_{12} + E_{23}) = L_x + iL_y = -\sqrt{2} \mathbf{v}_1^1$$

$$L_- \equiv \sqrt{2} \begin{pmatrix} \cdot & \cdot & \cdot \\ 1 & \cdot & \cdot \\ \cdot & 1 & \cdot \end{pmatrix} = \sqrt{2}(E_{21} + E_{32}) = L_x - iL_y = \sqrt{2} \mathbf{v}_{=1}^1$$

$$L_- \begin{matrix} L \\ M \end{matrix} \rangle = \sqrt{(L+M)(L-M+1)} \begin{matrix} L \\ M-1 \end{matrix} \rangle$$

$$L_- \begin{matrix} 2 \\ 2 \end{matrix} \rangle = \sqrt{(2+2)(2-2+1)} \begin{matrix} 2 \\ 1 \end{matrix} \rangle = 2 \begin{matrix} 2 \\ 1 \end{matrix} \rangle$$

Start with top $[2,1]$ -state:

$$\begin{matrix} 2 \\ 2 \end{matrix} \rangle = \begin{matrix} \square \square \\ \square \end{matrix} \rangle = \begin{matrix} 2 \\ D_{M=2} \end{matrix} \rangle$$

$$\begin{matrix} 2 \\ 1 \end{matrix} \rangle = \frac{1}{2} L_- \begin{matrix} 2 \\ 2 \end{matrix} \rangle = \frac{1}{2} \sqrt{2} (E_{21} + E_{32}) \begin{matrix} \square \square \\ \square \end{matrix} \rangle = \frac{1}{\sqrt{2}} \begin{matrix} \square \square \\ \square \end{matrix} \rangle + \frac{1}{\sqrt{2}} \begin{matrix} \square \square \\ \square \end{matrix} \rangle = \begin{matrix} 2 \\ D_{M=1} \end{matrix} \rangle$$

Orthogonal $M=1$ state: $\begin{matrix} 2 \\ P_{M=1} \end{matrix} \rangle = \begin{matrix} 1 \\ 1 \end{matrix} \rangle = \frac{1}{\sqrt{2}} \begin{matrix} \square \square \\ \square \end{matrix} \rangle - \frac{1}{\sqrt{2}} \begin{matrix} \square \square \\ \square \end{matrix} \rangle = \begin{matrix} 2 \\ P_{M=1} \end{matrix} \rangle$

$\square\square = [2,1]$ tableau states lowered by $L_- = \sqrt{2}(E_{21} + E_{32})$

E_{jk}	$M=2$	$M=1$	$M=0$	$M=-1$	$M=-2$
$\begin{vmatrix} 11 \\ 2 \end{vmatrix}$	$\begin{vmatrix} 11 \\ 2 \end{vmatrix}$	$\begin{vmatrix} 12 \\ 2 \end{vmatrix}$	$\begin{vmatrix} 11 \\ 3 \end{vmatrix}$	$\begin{vmatrix} 12 \\ 3 \end{vmatrix}$	$\begin{vmatrix} 13 \\ 2 \end{vmatrix}$
$\langle \begin{vmatrix} 11 \\ 2 \end{vmatrix} $	$\begin{matrix} (11) & (22) \\ 2 & +1 \end{matrix}$	$\begin{matrix} (12) & (23) \\ 1 & 1 \end{matrix}$	$\begin{matrix} (13) \\ -\sqrt{\frac{1}{2}} \end{matrix}$	$\begin{matrix} (13) \\ \sqrt{\frac{3}{2}} \end{matrix}$	$\begin{matrix} \cdot & \cdot \\ \cdot & \cdot \end{matrix}$
$\langle \begin{vmatrix} 12 \\ 2 \end{vmatrix} $	$\begin{matrix} (21) \\ 1 \end{matrix}$	$\begin{matrix} (11) & (22) \\ 1 & +2 \end{matrix}$	$\begin{matrix} (23) \\ \sqrt{\frac{1}{2}} \end{matrix}$	$\begin{matrix} (23) \\ \sqrt{\frac{3}{2}} \end{matrix}$	$\begin{matrix} \cdot & (13) \\ \cdot & -1 \end{matrix}$
$\langle \begin{vmatrix} 11 \\ 3 \end{vmatrix} $	$\begin{matrix} (32) \\ 1 \end{matrix}$	\cdot	$\begin{matrix} (11) & (33) \\ 2 & +1 \end{matrix}$	$\begin{matrix} (12) \\ \sqrt{2} \end{matrix}$	$\begin{matrix} (13) \\ 1 \end{matrix}$
$\langle \begin{vmatrix} 12 \\ 3 \end{vmatrix} $	$\begin{matrix} (31) \\ -\sqrt{\frac{1}{2}} \end{matrix}$	$\begin{matrix} (32) \\ \sqrt{\frac{1}{2}} \end{matrix}$	$\begin{matrix} (21) \\ \sqrt{2} \end{matrix}$	$\begin{matrix} (11) & (22) & (33) \\ 1 & +1 & +1 \end{matrix}$	$\begin{matrix} (23) & (12) \\ \sqrt{\frac{1}{2}} & \sqrt{2} \end{matrix}$
$\langle \begin{vmatrix} 13 \\ 2 \end{vmatrix} $	$\begin{matrix} (31) \\ \sqrt{\frac{3}{2}} \end{matrix}$	$\begin{matrix} (32) \\ \sqrt{\frac{3}{2}} \end{matrix}$	\cdot	$\begin{matrix} (11) & (22) & (33) \\ 1 & +1 & +1 \end{matrix}$	$\begin{matrix} (23) & \cdot \\ \sqrt{\frac{3}{2}} & \cdot \end{matrix}$
$\langle \begin{vmatrix} 13 \\ 3 \end{vmatrix} $	\cdot	\cdot	$\begin{matrix} (31) \\ 1 \end{matrix}$	$\begin{matrix} (32) \\ \sqrt{\frac{1}{2}} \end{matrix}$	$\begin{matrix} (11) & (33) \\ 1 & +2 \end{matrix}$
$\langle \begin{vmatrix} 22 \\ 3 \end{vmatrix} $	\cdot	$\begin{matrix} (31) \\ -1 \end{matrix}$	\cdot	$\begin{matrix} (21) \\ \sqrt{2} \end{matrix}$	$\begin{matrix} (22) & (33) \\ 2 & +1 \end{matrix}$
$\langle \begin{vmatrix} 23 \\ 3 \end{vmatrix} $	\cdot	\cdot	\cdot	$\begin{matrix} (31) \\ \sqrt{\frac{1}{2}} \end{matrix}$	$\begin{matrix} (31) \\ \sqrt{\frac{3}{2}} \end{matrix}$

$L_z \equiv \begin{pmatrix} 1 & \cdot & \cdot \\ \cdot & 0 & \cdot \\ \cdot & \cdot & -1 \end{pmatrix} = (E_{11} - E_{33}) = \sqrt{2} \mathbf{v}_0^1$ dipole ($k=1$)
 \angle -momentum
L-operators

E_{jk} -matrix
 Lect.23
 p.7-16
 and p.74

$L_+ \equiv \sqrt{2} \begin{pmatrix} \cdot & 1 & \cdot \\ \cdot & \cdot & 1 \\ \cdot & \cdot & \cdot \end{pmatrix} = \sqrt{2}(E_{12} + E_{23}) = L_x + iL_y = -\sqrt{2} \mathbf{v}_1^1$

$L_- \equiv \sqrt{2} \begin{pmatrix} \cdot & \cdot & \cdot \\ 1 & \cdot & \cdot \\ \cdot & 1 & \cdot \end{pmatrix} = \sqrt{2}(E_{21} + E_{32}) = L_x - iL_y = \sqrt{2} \mathbf{v}_{=1}^1$

$L_- \begin{vmatrix} L \\ M \end{vmatrix} = \sqrt{(L+M)(L-M+1)} \begin{vmatrix} L \\ M-1 \end{vmatrix}$

$L_- \begin{vmatrix} 2 \\ 2 \end{vmatrix} = \sqrt{(2+2)(2-2+1)} \begin{vmatrix} 2 \\ 1 \end{vmatrix} = 2 \begin{vmatrix} 2 \\ 1 \end{vmatrix}$

$\begin{vmatrix} 2 \\ 1 \end{vmatrix} = \frac{1}{2} L_- \begin{vmatrix} 2 \\ 2 \end{vmatrix} = \frac{1}{2} \sqrt{2} (E_{21} + E_{32}) \begin{vmatrix} 11 \\ 2 \end{vmatrix} = \frac{1}{\sqrt{2}} \begin{vmatrix} 12 \\ 2 \end{vmatrix} + \frac{1}{\sqrt{2}} \begin{vmatrix} 11 \\ 3 \end{vmatrix} = \begin{vmatrix} 2 \\ 1 \end{vmatrix}$

Orthogonal $M=1$ state: $\begin{vmatrix} 2 \\ 1 \end{vmatrix} = \begin{vmatrix} 1 \\ 1 \end{vmatrix} = \frac{1}{\sqrt{2}} \begin{vmatrix} 12 \\ 2 \end{vmatrix} - \frac{1}{\sqrt{2}} \begin{vmatrix} 11 \\ 3 \end{vmatrix} = \begin{vmatrix} 2 \\ 1 \end{vmatrix}$

Start with top $[2,1]$ -state:

$\begin{vmatrix} 2 \\ 2 \end{vmatrix} = \begin{vmatrix} 11 \\ 2 \end{vmatrix} = \begin{vmatrix} 2 \\ 2 \end{vmatrix}$

$\begin{vmatrix} 2 \\ 1 \end{vmatrix} = \frac{1}{\sqrt{2}} \begin{vmatrix} 12 \\ 2 \end{vmatrix} + \frac{1}{\sqrt{2}} \begin{vmatrix} 11 \\ 3 \end{vmatrix} = \begin{vmatrix} 2 \\ 1 \end{vmatrix}$

4.23.18 class 25: *Symmetry Principles for Advanced Atomic-Molecular-Optical-Physics*

William G. Harter - University of Arkansas

$(S_3)^*(U(3)) \subset U(6)$ models of p^3 electronic spin-orbit states and couplings

$[2,1]$ tableau states lowered by $L_- = \sqrt{2}(E_{21} + E_{32})$

Top-(J,M) states  thru mid-level states

$\ell=1$ p -shell LS states combined to states of definite J

J=3/2 at L=0 (4S). J=5/2 at L=2 (2D)

Clebsch-Gordon coupling; J=3/2 at L=2 (2D)

J=3/2 at L=1 (2P)

J=1/2 at L=1 (2P)

Spin-orbit state assembly formula and Slater determinants

The simplest assembly

$\ell=1$ p -shell LSJ states transformed to Slater determinants from J=3/2 (4S)

Slater functions for J=5/2 (2D)

Slater functions for J=3/2 (2D)

Slater functions for J=3/2 (2P)

Application to spin-orbit and entanglement break-up scattering

$\square\square = [2,1]$ tableau states lowered by $L_- = \sqrt{2}(E_{21} + E_{32})$

	$M=2$	$M=1$	$M=0$	$M=-1$	$M=-2$		
E_{jk}	$\begin{vmatrix} 11 \\ 2 \end{vmatrix}$	$\begin{vmatrix} 12 \\ 2 \end{vmatrix}$ $\begin{vmatrix} 11 \\ 3 \end{vmatrix}$	$\begin{vmatrix} 12 \\ 3 \end{vmatrix}$ $\begin{vmatrix} 13 \\ 2 \end{vmatrix}$	$\begin{vmatrix} 13 \\ 3 \end{vmatrix}$ $\begin{vmatrix} 22 \\ 3 \end{vmatrix}$	$\begin{vmatrix} 23 \\ 3 \end{vmatrix}$		
$\langle \begin{vmatrix} 11 \\ 2 \end{vmatrix} $	$\begin{matrix} (11) & (22) \\ 2 & + & 1 \end{matrix}$	$\begin{matrix} (12) & (23) \\ 1 & & 1 \end{matrix}$	$\begin{matrix} (13) \\ -\sqrt{\frac{1}{2}} \end{matrix}$ $\begin{matrix} (13) \\ \sqrt{\frac{3}{2}} \end{matrix}$	\cdot \cdot	\cdot		
$\langle \begin{vmatrix} 12 \\ 2 \end{vmatrix} $	$\begin{matrix} (21) \\ 1 \end{matrix}$	$\begin{matrix} (11) & (22) \\ 1 & + & 2 \end{matrix}$	$\begin{matrix} (23) \\ \sqrt{\frac{1}{2}} \end{matrix}$ $\begin{matrix} (23) \\ \sqrt{\frac{3}{2}} \end{matrix}$	\cdot $\begin{matrix} (13) \\ -1 \end{matrix}$	\cdot		
$\langle \begin{vmatrix} 11 \\ 3 \end{vmatrix} $	$\begin{matrix} (32) \\ 1 \end{matrix}$	\cdot	$\begin{matrix} (11) & (33) \\ 2 & + & 1 \end{matrix}$	$\begin{matrix} (12) \\ \sqrt{2} \end{matrix}$	$\begin{matrix} (13) \\ 1 \end{matrix}$ \cdot	\cdot	
$\langle \begin{vmatrix} 12 \\ 3 \end{vmatrix} $	$\begin{matrix} (31) \\ -\sqrt{\frac{1}{2}} \end{matrix}$	$\begin{matrix} (32) \\ \sqrt{\frac{1}{2}} \end{matrix}$	$\begin{matrix} (21) \\ \sqrt{2} \end{matrix}$	$\begin{matrix} (11) & (22) & (33) \\ 1 & + & 1 & + & 1 \end{matrix}$	\cdot	$\begin{matrix} (23) & (12) \\ \sqrt{\frac{1}{2}} & \sqrt{2} \end{matrix}$	$\begin{matrix} (13) \\ \sqrt{\frac{1}{2}} \end{matrix}$
$\langle \begin{vmatrix} 13 \\ 2 \end{vmatrix} $	$\begin{matrix} (31) \\ \sqrt{\frac{3}{2}} \end{matrix}$	$\begin{matrix} (32) \\ \sqrt{\frac{3}{2}} \end{matrix}$	\cdot	\cdot	$\begin{matrix} (11) & (22) & (33) \\ 1 & + & 1 & + & 1 \end{matrix}$	$\begin{matrix} (23) \\ \sqrt{\frac{3}{2}} \end{matrix}$ \cdot	$\begin{matrix} (13) \\ \sqrt{\frac{3}{2}} \end{matrix}$
$\langle \begin{vmatrix} 13 \\ 3 \end{vmatrix} $	\cdot	\cdot	$\begin{matrix} (31) \\ 1 \end{matrix}$	$\begin{matrix} (32) \\ \sqrt{\frac{1}{2}} \end{matrix}$ $\begin{matrix} (32) \\ \sqrt{\frac{3}{2}} \end{matrix}$	$\begin{matrix} (11) & (33) \\ 1 & + & 2 \end{matrix}$	\cdot	$\begin{matrix} (12) \\ 1 \end{matrix}$
$\langle \begin{vmatrix} 22 \\ 3 \end{vmatrix} $	\cdot	$\begin{matrix} (31) \\ -1 \end{matrix}$	\cdot	$\begin{matrix} (21) \\ \sqrt{2} \end{matrix}$	\cdot	$\begin{matrix} (22) & (33) \\ 2 & + & 1 \end{matrix}$	$\begin{matrix} (23) \\ 1 \end{matrix}$
$\langle \begin{vmatrix} 23 \\ 3 \end{vmatrix} $	\cdot	\cdot	\cdot	$\begin{matrix} (31) \\ \sqrt{\frac{1}{2}} \end{matrix}$ $\begin{matrix} (31) \\ \sqrt{\frac{3}{2}} \end{matrix}$	$\begin{matrix} (21) & (32) \\ 1 & & 1 \end{matrix}$	$\begin{matrix} (22) & (33) \\ 1 & + & 2 \end{matrix}$	$\begin{matrix} (22) & (33) \\ 1 & + & 2 \end{matrix}$

$L_z \equiv \begin{pmatrix} 1 & \cdot & \cdot \\ \cdot & 0 & \cdot \\ \cdot & \cdot & -1 \end{pmatrix} = (E_{11} - E_{33}) = \sqrt{2} \mathbf{v}_0^1$ dipole ($k=1$)
 \angle -momentum
L-operators

E_{jk} -matrix
 Lect. 23
 p. 7-16
 and p. 74

$L_+ \equiv \sqrt{2} \begin{pmatrix} \cdot & 1 & \cdot \\ \cdot & \cdot & 1 \\ \cdot & \cdot & \cdot \end{pmatrix} = \sqrt{2}(E_{12} + E_{23}) = L_x + iL_y = -\sqrt{2} \mathbf{v}_1^1$

$L_- \equiv \sqrt{2} \begin{pmatrix} \cdot & \cdot & \cdot \\ 1 & \cdot & \cdot \\ \cdot & 1 & \cdot \end{pmatrix} = \sqrt{2}(E_{21} + E_{32}) = L_x - iL_y = \sqrt{2} \mathbf{v}_{=1}^1$

$L_- | \begin{vmatrix} 2 \\ 1 \end{vmatrix} \rangle = \sqrt{(2+1)(2-1+1)} | \begin{vmatrix} 2 \\ 1 \end{vmatrix} \rangle = \sqrt{6} | \begin{vmatrix} 2 \\ 0 \end{vmatrix} \rangle$

$L_- | \begin{matrix} L \\ M \end{matrix} \rangle = \sqrt{(L+M)(L-M+1)} | \begin{matrix} L \\ M-1 \end{matrix} \rangle$ Start with top $[2,1]$ -state:

$L_- | \begin{vmatrix} 2 \\ 2 \end{vmatrix} \rangle = \sqrt{(2+2)(2-2+1)} | \begin{vmatrix} 2 \\ 1 \end{vmatrix} \rangle = 2 | \begin{vmatrix} 2 \\ 1 \end{vmatrix} \rangle$ $| \begin{vmatrix} 2 \\ 2 \end{vmatrix} \rangle = | \begin{vmatrix} \square\square \\ \square \end{vmatrix} \rangle = | {}^2D_{M=2} \rangle$

$| \begin{vmatrix} 2 \\ 1 \end{vmatrix} \rangle = \frac{1}{2} L_- | \begin{vmatrix} 2 \\ 2 \end{vmatrix} \rangle = \frac{1}{2} \sqrt{2} (E_{21} + E_{32}) | \begin{vmatrix} \square\square \\ \square \end{vmatrix} \rangle = \frac{1}{\sqrt{2}} | \begin{vmatrix} \square\square \\ \square \end{vmatrix} \rangle + \frac{1}{\sqrt{2}} | \begin{vmatrix} \square\square \\ \square \end{vmatrix} \rangle = | {}^2D_{M=1} \rangle$

Orthogonal $M=1$ state: $| {}^2P_{M=1} \rangle = | \begin{vmatrix} 1 \\ 1 \end{vmatrix} \rangle = \frac{1}{\sqrt{2}} | \begin{vmatrix} \square\square \\ \square \end{vmatrix} \rangle - \frac{1}{\sqrt{2}} | \begin{vmatrix} \square\square \\ \square \end{vmatrix} \rangle = | {}^2P_{M=1} \rangle$

$\square\square = [2,1]$ tableau states lowered by $L_- = \sqrt{2}(E_{21} + E_{32})$

	$M=2$	$M=1$	$M=0$	$M=-1$	$M=-2$
E_{jk}	$\begin{smallmatrix} 11 \\ 2 \end{smallmatrix}$	$\begin{smallmatrix} 12 \\ 2 \end{smallmatrix}$ $\begin{smallmatrix} 11 \\ 3 \end{smallmatrix}$	$\begin{smallmatrix} 12 \\ 3 \end{smallmatrix}$ $\begin{smallmatrix} 13 \\ 2 \end{smallmatrix}$	$\begin{smallmatrix} 13 \\ 3 \end{smallmatrix}$ $\begin{smallmatrix} 22 \\ 3 \end{smallmatrix}$	$\begin{smallmatrix} 23 \\ 3 \end{smallmatrix}$
$\langle \begin{smallmatrix} 11 \\ 2 \end{smallmatrix} $	$\begin{smallmatrix} (11) & (22) \\ 2 & +1 \end{smallmatrix}$	$\begin{smallmatrix} (12) & (23) \\ 1 & 1 \end{smallmatrix}$	$\begin{smallmatrix} (13) & (13) \\ -\sqrt{\frac{1}{2}} & \sqrt{\frac{3}{2}} \end{smallmatrix}$	\cdot \cdot	\cdot
$\langle \begin{smallmatrix} 12 \\ 2 \end{smallmatrix} $	$\begin{smallmatrix} (21) \\ 1 \end{smallmatrix}$	$\begin{smallmatrix} (11) & (22) \\ 1 & +2 \end{smallmatrix}$	$\begin{smallmatrix} (23) & (23) \\ \sqrt{\frac{1}{2}} & \sqrt{\frac{3}{2}} \end{smallmatrix}$	\cdot $\begin{smallmatrix} (13) \\ -1 \end{smallmatrix}$	\cdot
$\langle \begin{smallmatrix} 11 \\ 3 \end{smallmatrix} $	$\begin{smallmatrix} (32) \\ 1 \end{smallmatrix}$	\cdot	$\begin{smallmatrix} (11) & (33) \\ 2 & +1 \end{smallmatrix}$	$\begin{smallmatrix} (12) \\ \sqrt{2} \end{smallmatrix}$	\cdot
$\langle \begin{smallmatrix} 12 \\ 3 \end{smallmatrix} $	$\begin{smallmatrix} (31) \\ -\sqrt{\frac{1}{2}} \end{smallmatrix}$	$\begin{smallmatrix} (32) \\ \sqrt{\frac{1}{2}} \end{smallmatrix}$	$\begin{smallmatrix} (21) \\ \sqrt{2} \end{smallmatrix}$	$\begin{smallmatrix} (11) & (22) & (33) \\ 1 & +1 & +1 \end{smallmatrix}$	\cdot
$\langle \begin{smallmatrix} 13 \\ 2 \end{smallmatrix} $	$\begin{smallmatrix} (31) \\ \sqrt{\frac{3}{2}} \end{smallmatrix}$	$\begin{smallmatrix} (32) \\ \sqrt{\frac{3}{2}} \end{smallmatrix}$	\cdot	$\begin{smallmatrix} (11) & (22) & (33) \\ 1 & +1 & +1 \end{smallmatrix}$	$\begin{smallmatrix} (23) & (12) \\ \sqrt{\frac{3}{2}} & \cdot \end{smallmatrix}$
$\langle \begin{smallmatrix} 13 \\ 3 \end{smallmatrix} $	\cdot	\cdot	$\begin{smallmatrix} (31) \\ 1 \end{smallmatrix}$	$\begin{smallmatrix} (32) \\ \sqrt{\frac{1}{2}} \end{smallmatrix}$ $\begin{smallmatrix} (32) \\ \sqrt{\frac{3}{2}} \end{smallmatrix}$	$\begin{smallmatrix} (11) & (33) \\ 1 & +2 \end{smallmatrix}$ $\begin{smallmatrix} (12) \\ 1 \end{smallmatrix}$
$\langle \begin{smallmatrix} 22 \\ 3 \end{smallmatrix} $	\cdot	$\begin{smallmatrix} (31) \\ -1 \end{smallmatrix}$	\cdot	$\begin{smallmatrix} (21) \\ \sqrt{2} \end{smallmatrix}$	\cdot $\begin{smallmatrix} (22) & (33) \\ 2 & +1 \end{smallmatrix}$ $\begin{smallmatrix} (23) \\ 1 \end{smallmatrix}$
$\langle \begin{smallmatrix} 23 \\ 3 \end{smallmatrix} $	\cdot	\cdot	\cdot	$\begin{smallmatrix} (31) \\ \sqrt{\frac{1}{2}} \end{smallmatrix}$ $\begin{smallmatrix} (31) \\ \sqrt{\frac{3}{2}} \end{smallmatrix}$	$\begin{smallmatrix} (21) & (32) \\ 1 & 1 \end{smallmatrix}$ $\begin{smallmatrix} (22) & (33) \\ 1 & +2 \end{smallmatrix}$

$L_z \equiv \begin{pmatrix} 1 & \cdot & \cdot \\ \cdot & 0 & \cdot \\ \cdot & \cdot & -1 \end{pmatrix} = (E_{11} - E_{33}) = \sqrt{2} \mathbf{v}_0^1$ dipole ($k=1$)
 \angle -momentum
L-operators

E_{jk}-matrix
Lect.23
p.7-16
and p.74

$L_+ \equiv \sqrt{2} \begin{pmatrix} \cdot & 1 & \cdot \\ \cdot & \cdot & 1 \\ \cdot & \cdot & \cdot \end{pmatrix} = \sqrt{2}(E_{12} + E_{23}) = L_x + iL_y = -\sqrt{2} \mathbf{v}_1^1$

$L_- \equiv \sqrt{2} \begin{pmatrix} \cdot & \cdot & \cdot \\ 1 & \cdot & \cdot \\ \cdot & 1 & \cdot \end{pmatrix} = \sqrt{2}(E_{21} + E_{32}) = L_x - iL_y = \sqrt{2} \mathbf{v}_{=1}^1$

$L_- | \begin{smallmatrix} 2 \\ 1 \end{smallmatrix} \rangle = \sqrt{(2+1)(2-1+1)} | \begin{smallmatrix} 2 \\ 0 \end{smallmatrix} \rangle = \sqrt{6} | \begin{smallmatrix} 2 \\ 0 \end{smallmatrix} \rangle$

$| \begin{smallmatrix} 2 \\ 0 \end{smallmatrix} \rangle = \frac{1}{\sqrt{6}} L_- | \begin{smallmatrix} 2 \\ 1 \end{smallmatrix} \rangle = \frac{1}{\sqrt{6}} \sqrt{2} (E_{21} + E_{32}) \frac{1}{\sqrt{2}} \left(\left| \begin{smallmatrix} 12 \\ 2 \end{smallmatrix} \right\rangle + \left| \begin{smallmatrix} 11 \\ 3 \end{smallmatrix} \right\rangle \right)$

$L_- | \begin{smallmatrix} L \\ M \end{smallmatrix} \rangle = \sqrt{(L+M)(L-M+1)} | \begin{smallmatrix} L \\ M-1 \end{smallmatrix} \rangle$

$L_- | \begin{smallmatrix} 2 \\ 2 \end{smallmatrix} \rangle = \sqrt{(2+2)(2-2+1)} | \begin{smallmatrix} 2 \\ 1 \end{smallmatrix} \rangle = 2 | \begin{smallmatrix} 2 \\ 1 \end{smallmatrix} \rangle$

$| \begin{smallmatrix} 2 \\ 1 \end{smallmatrix} \rangle = \frac{1}{2} L_- | \begin{smallmatrix} 2 \\ 2 \end{smallmatrix} \rangle = \frac{1}{2} \sqrt{2} (E_{21} + E_{32}) \left| \begin{smallmatrix} 11 \\ 2 \end{smallmatrix} \right\rangle = \frac{1}{\sqrt{2}} \left| \begin{smallmatrix} 12 \\ 2 \end{smallmatrix} \right\rangle + \frac{1}{\sqrt{2}} \left| \begin{smallmatrix} 11 \\ 3 \end{smallmatrix} \right\rangle = | \begin{smallmatrix} 2 \\ 1 \end{smallmatrix} \rangle$

Orthogonal $M=1$ state: $| \begin{smallmatrix} 2 \\ 1 \end{smallmatrix} \rangle = | \begin{smallmatrix} 1 \\ 1 \end{smallmatrix} \rangle = \frac{1}{\sqrt{2}} \left| \begin{smallmatrix} 12 \\ 2 \end{smallmatrix} \right\rangle - \frac{1}{\sqrt{2}} \left| \begin{smallmatrix} 11 \\ 3 \end{smallmatrix} \right\rangle = | \begin{smallmatrix} 2 \\ 1 \end{smallmatrix} \rangle$

Start with top $[2,1]$ -state:

$| \begin{smallmatrix} 2 \\ 2 \end{smallmatrix} \rangle = \left| \begin{smallmatrix} 11 \\ 2 \end{smallmatrix} \right\rangle = | \begin{smallmatrix} 2 \\ 2 \end{smallmatrix} \rangle = | \begin{smallmatrix} 2 \\ 2 \end{smallmatrix} \rangle$

$\square\square = [2,1]$ tableau states lowered by $L_- = \sqrt{2}(E_{21} + E_{32})$

E_{jk}	$M=2$	$M=1$	$M=0$	$M=-1$	$M=-2$
$\begin{vmatrix} 11 \\ 2 \end{vmatrix}$	$\begin{vmatrix} 11 \\ 2 \end{vmatrix}$	$\begin{vmatrix} 12 \\ 2 \end{vmatrix}$	$\begin{vmatrix} 11 \\ 3 \end{vmatrix}$	$\begin{vmatrix} 12 \\ 3 \end{vmatrix}$	$\begin{vmatrix} 13 \\ 2 \end{vmatrix}$
$\langle \begin{vmatrix} 11 \\ 2 \end{vmatrix} $	$\begin{matrix} (11) & (22) \\ 2 & +1 \end{matrix}$	$\begin{matrix} (12) & (23) \\ 1 & 1 \end{matrix}$	$\begin{matrix} (13) \\ -\sqrt{\frac{1}{2}} \end{matrix}$	$\begin{matrix} (13) \\ \sqrt{\frac{3}{2}} \end{matrix}$	\cdot
$\langle \begin{vmatrix} 12 \\ 2 \end{vmatrix} $	$\begin{matrix} (21) \\ 1 \end{matrix}$	$\begin{matrix} (11) & (22) \\ 1 & +2 \end{matrix}$	$\begin{matrix} (23) \\ \sqrt{\frac{1}{2}} \end{matrix}$	$\begin{matrix} (23) \\ \sqrt{\frac{3}{2}} \end{matrix}$	$\begin{matrix} (13) \\ -1 \end{matrix}$
$\langle \begin{vmatrix} 11 \\ 3 \end{vmatrix} $	$\begin{matrix} (32) \\ 1 \end{matrix}$	\cdot	$\begin{matrix} (11) & (33) \\ 2 & +1 \end{matrix}$	$\begin{matrix} (12) \\ \sqrt{2} \end{matrix}$	$\begin{matrix} (13) \\ 1 \end{matrix}$
$\langle \begin{vmatrix} 12 \\ 3 \end{vmatrix} $	$\begin{matrix} (31) \\ -\sqrt{\frac{1}{2}} \end{matrix}$	$\begin{matrix} (32) \\ \sqrt{\frac{1}{2}} \end{matrix}$	$\begin{matrix} (21) \\ \sqrt{2} \end{matrix}$	$\begin{matrix} (11) & (22) & (33) \\ 1 & +1 & +1 \end{matrix}$	$\begin{matrix} (23) \\ \sqrt{\frac{1}{2}} \end{matrix}$
$\langle \begin{vmatrix} 13 \\ 2 \end{vmatrix} $	$\begin{matrix} (31) \\ \sqrt{\frac{3}{2}} \end{matrix}$	$\begin{matrix} (32) \\ \sqrt{\frac{3}{2}} \end{matrix}$	\cdot	$\begin{matrix} (11) & (22) & (33) \\ 1 & +1 & +1 \end{matrix}$	$\begin{matrix} (23) \\ \sqrt{\frac{3}{2}} \end{matrix}$
$\langle \begin{vmatrix} 13 \\ 3 \end{vmatrix} $	\cdot	\cdot	$\begin{matrix} (31) \\ 1 \end{matrix}$	$\begin{matrix} (32) \\ \sqrt{\frac{1}{2}} \end{matrix}$	$\begin{matrix} (32) \\ \sqrt{\frac{3}{2}} \end{matrix}$
$\langle \begin{vmatrix} 22 \\ 3 \end{vmatrix} $	\cdot	$\begin{matrix} (31) \\ -1 \end{matrix}$	\cdot	$\begin{matrix} (21) \\ \sqrt{2} \end{matrix}$	$\begin{matrix} (11) & (33) \\ 1 & +2 \end{matrix}$
$\langle \begin{vmatrix} 23 \\ 3 \end{vmatrix} $	\cdot	\cdot	\cdot	$\begin{matrix} (21) \\ \sqrt{\frac{1}{2}} \end{matrix}$	$\begin{matrix} (32) \\ \sqrt{\frac{3}{2}} \end{matrix}$

$L_z \equiv \begin{pmatrix} 1 & \cdot & \cdot \\ \cdot & 0 & \cdot \\ \cdot & \cdot & -1 \end{pmatrix} = (E_{11} - E_{33}) = \sqrt{2}\mathbf{v}_0^1$ dipole ($k=1$)
 \angle -momentum
L-operators

E_{jk}-matrix
Lect.23
p.7-16
and p.74

$L_+ \equiv \sqrt{2} \begin{pmatrix} \cdot & 1 & \cdot \\ \cdot & \cdot & 1 \\ \cdot & \cdot & \cdot \end{pmatrix} = \sqrt{2}(E_{12} + E_{23}) = L_x + iL_y = -\sqrt{2}\mathbf{v}_1^1$

$L_- \equiv \sqrt{2} \begin{pmatrix} \cdot & \cdot & \cdot \\ 1 & \cdot & \cdot \\ \cdot & 1 & \cdot \end{pmatrix} = \sqrt{2}(E_{21} + E_{32}) = L_x - iL_y = \sqrt{2}\mathbf{v}_{=1}^1$

$L_- | \begin{vmatrix} 2 \\ 1 \end{vmatrix} \rangle = \sqrt{(2+1)(2-1+1)} | \begin{vmatrix} 2 \\ 0 \end{vmatrix} \rangle = \sqrt{6} | \begin{vmatrix} 2 \\ 0 \end{vmatrix} \rangle$

$| \begin{vmatrix} 2 \\ 0 \end{vmatrix} \rangle = \frac{1}{\sqrt{6}} L_- | \begin{vmatrix} 2 \\ 1 \end{vmatrix} \rangle = \frac{1}{\sqrt{6}} \sqrt{2} (E_{21} + E_{32}) \frac{1}{\sqrt{2}} \left(| \begin{vmatrix} 12 \\ 2 \end{vmatrix} \rangle + | \begin{vmatrix} 11 \\ 3 \end{vmatrix} \rangle \right)$

$= \frac{1}{\sqrt{6}} \left(E_{21} | \begin{vmatrix} 12 \\ 2 \end{vmatrix} \rangle + E_{21} | \begin{vmatrix} 11 \\ 3 \end{vmatrix} \rangle + E_{32} | \begin{vmatrix} 12 \\ 2 \end{vmatrix} \rangle + E_{32} | \begin{vmatrix} 11 \\ 3 \end{vmatrix} \rangle \right)$

$L_- | \begin{matrix} L \\ M \end{matrix} \rangle = \sqrt{(L+M)(L-M+1)} | \begin{matrix} L \\ M-1 \end{matrix} \rangle$

$L_- | \begin{vmatrix} 2 \\ 2 \end{vmatrix} \rangle = \sqrt{(2+2)(2-2+1)} | \begin{vmatrix} 2 \\ 1 \end{vmatrix} \rangle = 2 | \begin{vmatrix} 2 \\ 1 \end{vmatrix} \rangle$

$| \begin{vmatrix} 2 \\ 1 \end{vmatrix} \rangle = \frac{1}{2} L_- | \begin{vmatrix} 2 \\ 2 \end{vmatrix} \rangle = \frac{1}{2} \sqrt{2} (E_{21} + E_{32}) | \begin{vmatrix} 11 \\ 2 \end{vmatrix} \rangle = \frac{1}{\sqrt{2}} | \begin{vmatrix} 12 \\ 2 \end{vmatrix} \rangle + \frac{1}{\sqrt{2}} | \begin{vmatrix} 11 \\ 3 \end{vmatrix} \rangle = | \begin{matrix} 2 \\ M=1 \end{matrix} \rangle$

Orthogonal $M=1$ state: $| \begin{matrix} 2 \\ P_{M=1} \end{matrix} \rangle = | \begin{matrix} 1 \\ 1 \end{matrix} \rangle = \frac{1}{\sqrt{2}} | \begin{vmatrix} 12 \\ 2 \end{vmatrix} \rangle - \frac{1}{\sqrt{2}} | \begin{vmatrix} 11 \\ 3 \end{vmatrix} \rangle = | \begin{matrix} 2 \\ P_{M=1} \end{matrix} \rangle$

Start with top $[2,1]$ -state:
 $| \begin{vmatrix} 2 \\ 2 \end{vmatrix} \rangle = | \begin{vmatrix} 11 \\ 2 \end{vmatrix} \rangle = | \begin{matrix} 2 \\ D_{M=2} \end{matrix} \rangle$

$\square\square = [2,1]$ tableau states lowered by $L_- = \sqrt{2}(E_{21} + E_{32})$

E_{jk}	$M=2$	$M=1$	$M=0$	$M=-1$	$M=-2$
$\begin{smallmatrix} 11\rangle \\ 2 \end{smallmatrix}$	$\begin{smallmatrix} (11) & (22) \\ 2 & +1 \end{smallmatrix}$	$\begin{smallmatrix} (12) & (23) \\ 1 & 1 \end{smallmatrix}$	$\begin{smallmatrix} (13) \\ -\sqrt{\frac{1}{2}} \end{smallmatrix}$	$\begin{smallmatrix} (13) \\ \sqrt{\frac{3}{2}} \end{smallmatrix}$	$\begin{smallmatrix} (13) & (22) \\ 3 & 3 \end{smallmatrix}$
$\begin{smallmatrix} 12\rangle \\ 2 \end{smallmatrix}$	$\begin{smallmatrix} (21) \\ 1 \end{smallmatrix}$	$\begin{smallmatrix} (11) & (22) \\ 1 & +2 \end{smallmatrix}$	$\begin{smallmatrix} (23) \\ \sqrt{\frac{1}{2}} \end{smallmatrix}$	$\begin{smallmatrix} (23) \\ \sqrt{\frac{3}{2}} \end{smallmatrix}$	$\begin{smallmatrix} (13) \\ -1 \end{smallmatrix}$
$\begin{smallmatrix} 11\rangle \\ 3 \end{smallmatrix}$	$\begin{smallmatrix} (32) \\ 1 \end{smallmatrix}$	$\begin{smallmatrix} (11) & (33) \\ \cdot & 2+1 \end{smallmatrix}$	$\begin{smallmatrix} (12) \\ \sqrt{2} \end{smallmatrix}$	$\begin{smallmatrix} (13) \\ \cdot \end{smallmatrix}$	$\begin{smallmatrix} (13) \\ \cdot \end{smallmatrix}$
$\begin{smallmatrix} 12\rangle \\ 3 \end{smallmatrix}$	$\begin{smallmatrix} (31) \\ -\sqrt{\frac{1}{2}} \end{smallmatrix}$	$\begin{smallmatrix} (32) \\ \sqrt{\frac{1}{2}} \end{smallmatrix}$	$\begin{smallmatrix} (21) \\ \sqrt{2} \end{smallmatrix}$	$\begin{smallmatrix} (11) & (22) & (33) \\ 1 & +1 & +1 \end{smallmatrix}$	$\begin{smallmatrix} (23) & (12) \\ \sqrt{\frac{1}{2}} & \sqrt{2} \end{smallmatrix}$
$\begin{smallmatrix} 13\rangle \\ 2 \end{smallmatrix}$	$\begin{smallmatrix} (31) \\ \sqrt{\frac{3}{2}} \end{smallmatrix}$	$\begin{smallmatrix} (32) \\ \sqrt{\frac{3}{2}} \end{smallmatrix}$	$\begin{smallmatrix} (11) & (22) & (33) \\ \cdot & \cdot & \cdot \end{smallmatrix}$	$\begin{smallmatrix} (11) & (22) & (33) \\ 1 & +1 & +1 \end{smallmatrix}$	$\begin{smallmatrix} (23) \\ \sqrt{\frac{3}{2}} \end{smallmatrix}$
$\begin{smallmatrix} 13\rangle \\ 3 \end{smallmatrix}$	$\begin{smallmatrix} (31) \\ \cdot \end{smallmatrix}$	$\begin{smallmatrix} (31) \\ \cdot \end{smallmatrix}$	$\begin{smallmatrix} (31) \\ 1 \end{smallmatrix}$	$\begin{smallmatrix} (32) \\ \sqrt{\frac{1}{2}} \end{smallmatrix}$	$\begin{smallmatrix} (32) \\ \sqrt{\frac{3}{2}} \end{smallmatrix}$
$\begin{smallmatrix} 22\rangle \\ 3 \end{smallmatrix}$	$\begin{smallmatrix} (31) \\ \cdot \end{smallmatrix}$	$\begin{smallmatrix} (31) \\ -1 \end{smallmatrix}$	$\begin{smallmatrix} (21) \\ \sqrt{2} \end{smallmatrix}$	$\begin{smallmatrix} (11) & (33) \\ 1 & +2 \end{smallmatrix}$	$\begin{smallmatrix} (22) & (33) \\ 2 & +1 \end{smallmatrix}$
$\begin{smallmatrix} 23\rangle \\ 3 \end{smallmatrix}$	$\begin{smallmatrix} (31) \\ \cdot \end{smallmatrix}$	$\begin{smallmatrix} (31) \\ \cdot \end{smallmatrix}$	$\begin{smallmatrix} (31) \\ \sqrt{\frac{1}{2}} \end{smallmatrix}$	$\begin{smallmatrix} (31) \\ \sqrt{\frac{3}{2}} \end{smallmatrix}$	$\begin{smallmatrix} (21) & (32) & (22) & (33) \\ 1 & 1 & 1 & +2 \end{smallmatrix}$

$L_z \equiv \begin{pmatrix} 1 & \cdot & \cdot \\ \cdot & 0 & \cdot \\ \cdot & \cdot & -1 \end{pmatrix} = (E_{11} - E_{33}) = \sqrt{2}\mathbf{v}_0^1$ dipole ($k=1$)
 \angle -momentum
L-operators

E_{jk}-matrix
 Lect.23
 p.7-16
 and p.74

$L_+ \equiv \sqrt{2} \begin{pmatrix} \cdot & 1 & \cdot \\ \cdot & \cdot & 1 \\ \cdot & \cdot & \cdot \end{pmatrix} = \sqrt{2}(E_{12} + E_{23}) = L_x + iL_y = -\sqrt{2}\mathbf{v}_1^1$

$L_- \equiv \sqrt{2} \begin{pmatrix} \cdot & \cdot & \cdot \\ 1 & \cdot & \cdot \\ \cdot & 1 & \cdot \end{pmatrix} = \sqrt{2}(E_{21} + E_{32}) = L_x - iL_y = \sqrt{2}\mathbf{v}_{=1}^1$

$L_- |^2_1\rangle = \sqrt{(2+1)(2-1+1)} |^2_0\rangle = \sqrt{6} |^2_0\rangle$

$|^2_0\rangle = \frac{1}{\sqrt{6}} L_- |^2_1\rangle = \frac{1}{\sqrt{6}} \sqrt{2}(E_{21} + E_{32}) \frac{1}{\sqrt{2}} \left(\begin{smallmatrix} |12\rangle \\ |2 \end{smallmatrix} + \begin{smallmatrix} |11\rangle \\ |3 \end{smallmatrix} \right)$

$= \frac{1}{\sqrt{6}} \left(E_{21} \begin{smallmatrix} |12\rangle \\ |2 \end{smallmatrix} + E_{21} \begin{smallmatrix} |11\rangle \\ |3 \end{smallmatrix} + E_{32} \begin{smallmatrix} |12\rangle \\ |2 \end{smallmatrix} + E_{32} \begin{smallmatrix} |11\rangle \\ |3 \end{smallmatrix} \right)$

$= \frac{1}{\sqrt{6}} \left(0 \begin{smallmatrix} |12\rangle \\ |2 \end{smallmatrix} + \sqrt{2} \begin{smallmatrix} |12\rangle \\ |3 \end{smallmatrix} + \sqrt{\frac{1}{2}} \begin{smallmatrix} |12\rangle \\ |3 \end{smallmatrix} + \sqrt{\frac{3}{2}} \begin{smallmatrix} |13\rangle \\ |2 \end{smallmatrix} + 0 \begin{smallmatrix} |11\rangle \\ |3 \end{smallmatrix} \right)$

$L_- |^L_M\rangle = \sqrt{(L+M)(L-M+1)} |^L_{M-1}\rangle$

$L_- |^2_2\rangle = \sqrt{(2+2)(2-2+1)} |^2_1\rangle = 2 |^2_1\rangle$

$|^2_1\rangle = \frac{1}{2} L_- |^2_2\rangle = \frac{1}{2} \sqrt{2}(E_{21} + E_{32}) \begin{smallmatrix} |11\rangle \\ |2 \end{smallmatrix} = \frac{1}{\sqrt{2}} \begin{smallmatrix} |12\rangle \\ |2 \end{smallmatrix} + \frac{1}{\sqrt{2}} \begin{smallmatrix} |11\rangle \\ |3 \end{smallmatrix} = |^2D_{M=1}\rangle$

Orthogonal $M=1$ state: $|^2P_{M=1}\rangle = \begin{smallmatrix} |1\rangle \\ |1 \end{smallmatrix} = \frac{1}{\sqrt{2}} \begin{smallmatrix} |12\rangle \\ |2 \end{smallmatrix} - \frac{1}{\sqrt{2}} \begin{smallmatrix} |11\rangle \\ |3 \end{smallmatrix} = |^2P_{M=1}\rangle$

Start with top $[2,1]$ -state:
 $|^2_2\rangle = \begin{smallmatrix} |11\rangle \\ |2 \end{smallmatrix} = |^2D_{M=2}\rangle$

$\square\square = [2,1]$ tableau states lowered by $L_- = \sqrt{2}(E_{21} + E_{32})$

E_{jk}	$M=2$	$M=1$	$M=0$	$M=-1$	$M=-2$
$\begin{smallmatrix} 11 \\ 2 \end{smallmatrix}$	$\begin{smallmatrix} 11 \\ 2 \end{smallmatrix}$	$\begin{smallmatrix} 12 \\ 2 \end{smallmatrix}$	$\begin{smallmatrix} 11 \\ 3 \end{smallmatrix}$	$\begin{smallmatrix} 12 \\ 3 \end{smallmatrix}$	$\begin{smallmatrix} 13 \\ 2 \end{smallmatrix}$
$\langle \begin{smallmatrix} 11 \\ 2 \end{smallmatrix} $	$\begin{smallmatrix} (11) & (22) \\ 2 & +1 \end{smallmatrix}$	$\begin{smallmatrix} (12) & (23) \\ 1 & 1 \end{smallmatrix}$	$\begin{smallmatrix} (13) \\ -\sqrt{\frac{1}{2}} \end{smallmatrix}$	$\begin{smallmatrix} (13) \\ \sqrt{\frac{3}{2}} \end{smallmatrix}$	$\begin{smallmatrix} (13) \\ \sqrt{\frac{3}{2}} \end{smallmatrix}$
$\langle \begin{smallmatrix} 12 \\ 2 \end{smallmatrix} $	$\begin{smallmatrix} (21) \\ 1 \end{smallmatrix}$	$\begin{smallmatrix} (11) & (22) \\ 1 & +2 \end{smallmatrix}$	$\begin{smallmatrix} (23) \\ \sqrt{\frac{1}{2}} \end{smallmatrix}$	$\begin{smallmatrix} (23) \\ \sqrt{\frac{3}{2}} \end{smallmatrix}$	$\begin{smallmatrix} (13) \\ -1 \end{smallmatrix}$
$\langle \begin{smallmatrix} 11 \\ 3 \end{smallmatrix} $	$\begin{smallmatrix} (32) \\ 1 \end{smallmatrix}$	\cdot	$\begin{smallmatrix} (11) & (33) \\ 2 & +1 \end{smallmatrix}$	$\begin{smallmatrix} (12) \\ \sqrt{2} \end{smallmatrix}$	$\begin{smallmatrix} (13) \\ 1 \end{smallmatrix}$
$\langle \begin{smallmatrix} 12 \\ 3 \end{smallmatrix} $	$\begin{smallmatrix} (31) \\ -\sqrt{\frac{1}{2}} \end{smallmatrix}$	$\begin{smallmatrix} (32) \\ \sqrt{\frac{1}{2}} \end{smallmatrix}$	$\begin{smallmatrix} (21) \\ \sqrt{2} \end{smallmatrix}$	$\begin{smallmatrix} (11) & (22) & (33) \\ 1 & +1 & +1 \end{smallmatrix}$	$\begin{smallmatrix} (23) \\ \sqrt{\frac{1}{2}} \end{smallmatrix}$
$\langle \begin{smallmatrix} 13 \\ 2 \end{smallmatrix} $	$\begin{smallmatrix} (31) \\ \sqrt{\frac{3}{2}} \end{smallmatrix}$	$\begin{smallmatrix} (32) \\ \sqrt{\frac{3}{2}} \end{smallmatrix}$	\cdot	$\begin{smallmatrix} (11) & (22) & (33) \\ 1 & +1 & +1 \end{smallmatrix}$	$\begin{smallmatrix} (23) \\ \sqrt{\frac{3}{2}} \end{smallmatrix}$
$\langle \begin{smallmatrix} 13 \\ 3 \end{smallmatrix} $	\cdot	\cdot	$\begin{smallmatrix} (31) \\ 1 \end{smallmatrix}$	$\begin{smallmatrix} (32) \\ \sqrt{\frac{1}{2}} \end{smallmatrix}$	$\begin{smallmatrix} (32) \\ \sqrt{\frac{3}{2}} \end{smallmatrix}$
$\langle \begin{smallmatrix} 22 \\ 3 \end{smallmatrix} $	\cdot	$\begin{smallmatrix} (31) \\ -1 \end{smallmatrix}$	\cdot	$\begin{smallmatrix} (21) \\ \sqrt{2} \end{smallmatrix}$	$\begin{smallmatrix} (11) & (33) \\ 1 & +2 \end{smallmatrix}$
$\langle \begin{smallmatrix} 23 \\ 3 \end{smallmatrix} $	\cdot	\cdot	\cdot	$\begin{smallmatrix} (21) \\ \sqrt{\frac{1}{2}} \end{smallmatrix}$	$\begin{smallmatrix} (32) \\ \sqrt{\frac{3}{2}} \end{smallmatrix}$

$L_z \equiv \begin{pmatrix} 1 & \cdot & \cdot \\ \cdot & 0 & \cdot \\ \cdot & \cdot & -1 \end{pmatrix} = (E_{11} - E_{33}) = \sqrt{2}\mathbf{v}_0^1$ dipole ($k=1$)
 \angle -momentum
 L -operators

E_{jk} -matrix
 Lect. 23
 p. 7-16
 and p. 74

$L_+ \equiv \sqrt{2} \begin{pmatrix} \cdot & 1 & \cdot \\ \cdot & \cdot & 1 \\ \cdot & \cdot & \cdot \end{pmatrix} = \sqrt{2}(E_{12} + E_{23}) = L_x + iL_y = -\sqrt{2}\mathbf{v}_1^1$

$L_- \equiv \sqrt{2} \begin{pmatrix} \cdot & \cdot & \cdot \\ 1 & \cdot & \cdot \\ \cdot & 1 & \cdot \end{pmatrix} = \sqrt{2}(E_{21} + E_{32}) = L_x - iL_y = \sqrt{2}\mathbf{v}_{-1}^1$

$L_- |^2_1\rangle = \sqrt{(2+1)(2-1+1)}|^2_0\rangle = \sqrt{6}|^2_0\rangle$

$|^2_0\rangle = \frac{1}{\sqrt{6}} L_- |^2_1\rangle = \frac{1}{\sqrt{6}} \sqrt{2}(E_{21} + E_{32}) \frac{1}{\sqrt{2}} \left(\begin{smallmatrix} 11 \\ 2 \end{smallmatrix} \rangle + \begin{smallmatrix} 11 \\ 3 \end{smallmatrix} \rangle \right)$

$= \frac{1}{\sqrt{6}} \left(E_{21} \begin{smallmatrix} 11 \\ 2 \end{smallmatrix} \rangle + E_{21} \begin{smallmatrix} 11 \\ 3 \end{smallmatrix} \rangle + E_{32} \begin{smallmatrix} 11 \\ 2 \end{smallmatrix} \rangle + E_{32} \begin{smallmatrix} 11 \\ 3 \end{smallmatrix} \rangle \right)$

$= \frac{1}{\sqrt{6}} \left(0 \begin{smallmatrix} 11 \\ 2 \end{smallmatrix} \rangle + \sqrt{2} \begin{smallmatrix} 11 \\ 3 \end{smallmatrix} \rangle + \sqrt{\frac{1}{2}} \begin{smallmatrix} 11 \\ 3 \end{smallmatrix} \rangle + \sqrt{\frac{3}{2}} \begin{smallmatrix} 11 \\ 2 \end{smallmatrix} \rangle + 0 \begin{smallmatrix} 11 \\ 3 \end{smallmatrix} \rangle \right)$

$= \frac{1}{\sqrt{6}} \left(\frac{3}{\sqrt{2}} \begin{smallmatrix} 11 \\ 3 \end{smallmatrix} \rangle + \sqrt{\frac{3}{2}} \begin{smallmatrix} 11 \\ 2 \end{smallmatrix} \rangle \right) = \frac{\sqrt{3}}{2} \begin{smallmatrix} 11 \\ 3 \end{smallmatrix} \rangle + \frac{1}{2} \begin{smallmatrix} 11 \\ 2 \end{smallmatrix} \rangle = |^2D_{M=0}\rangle = |^2_0\rangle$

Orthogonal ($L=1, M=0$) state: $\frac{-1}{2} \begin{smallmatrix} 11 \\ 3 \end{smallmatrix} \rangle + \frac{\sqrt{3}}{2} \begin{smallmatrix} 11 \\ 2 \end{smallmatrix} \rangle = |^2P_{M=0}\rangle = |^1_0\rangle$

$L_- |^L_M\rangle = \sqrt{(L+M)(L-M+1)}|^L_{M-1}\rangle$ Start with top $[2,1]$ -state:

$L_- |^2_2\rangle = \sqrt{(2+2)(2-2+1)}|^2_1\rangle = 2|^2_1\rangle$ $|^2_2\rangle = \begin{smallmatrix} 11 \\ 2 \end{smallmatrix} \rangle = |^2D_{M=2}\rangle$

$|^2_1\rangle = \frac{1}{2} L_- |^2_2\rangle = \frac{1}{2} \sqrt{2}(E_{21} + E_{32}) \begin{smallmatrix} 11 \\ 2 \end{smallmatrix} \rangle = \frac{1}{\sqrt{2}} \begin{smallmatrix} 11 \\ 2 \end{smallmatrix} \rangle + \frac{1}{\sqrt{2}} \begin{smallmatrix} 11 \\ 3 \end{smallmatrix} \rangle = |^2D_{M=1}\rangle$

Orthogonal $M=1$ state: $|^2P_{M=1}\rangle = |^1_1\rangle = \frac{1}{\sqrt{2}} \begin{smallmatrix} 11 \\ 2 \end{smallmatrix} \rangle - \frac{1}{\sqrt{2}} \begin{smallmatrix} 11 \\ 3 \end{smallmatrix} \rangle = |^2P_{M=1}\rangle$

$\square\square = [2,1]$ tableau states lowered by $L_- = \sqrt{2}(E_{21} + E_{32})$

	$M=2$	$M=1$	$M=0$	$M=-1$	$M=-2$
E_{jk}	$\begin{array}{ c } \hline 11 \\ \hline 2 \\ \hline \end{array}$	$\begin{array}{ c } \hline 12 \\ \hline 2 \\ \hline \end{array}$	$\begin{array}{ c } \hline 11 \\ \hline 3 \\ \hline \end{array}$	$\begin{array}{ c } \hline 12 \\ \hline 3 \\ \hline \end{array}$	$\begin{array}{ c } \hline 13 \\ \hline 2 \\ \hline \end{array}$
$\langle \begin{array}{ c } \hline 11 \\ \hline 2 \\ \hline \end{array} $	$\begin{array}{cc} (11) & (22) \\ 2 & +1 \end{array}$	$\begin{array}{cc} (12) & (23) \\ 1 & 1 \end{array}$	$\begin{array}{cc} (13) & (13) \\ -\sqrt{\frac{1}{2}} & \sqrt{\frac{3}{2}} \end{array}$	$\begin{array}{cc} (13) & (22) \\ \cdot & \cdot \end{array}$	$\begin{array}{c} (23) \\ \cdot \end{array}$
$\langle \begin{array}{ c } \hline 12 \\ \hline 2 \\ \hline \end{array} $	$\begin{array}{c} (21) \\ 1 \end{array}$	$\begin{array}{cc} (11) & (22) \\ 1 & +2 \end{array}$	$\begin{array}{cc} (23) & (23) \\ \sqrt{\frac{1}{2}} & \sqrt{\frac{3}{2}} \end{array}$	$\begin{array}{cc} (13) & (13) \\ \cdot & -1 \end{array}$	$\begin{array}{c} (23) \\ \cdot \end{array}$
$\langle \begin{array}{ c } \hline 11 \\ \hline 3 \\ \hline \end{array} $	$\begin{array}{c} (32) \\ 1 \end{array}$	\cdot	$\begin{array}{cc} (11) & (33) \\ 2 & +1 \end{array}$	$\begin{array}{cc} (12) & (12) \\ \sqrt{2} & \cdot \end{array}$	$\begin{array}{cc} (13) & (13) \\ 1 & \cdot \end{array}$
$\langle \begin{array}{ c } \hline 12 \\ \hline 3 \\ \hline \end{array} $	$\begin{array}{cc} (31) & (32) \\ -\sqrt{\frac{1}{2}} & \sqrt{\frac{1}{2}} \end{array}$	$\begin{array}{cc} (32) & (21) \\ \sqrt{\frac{1}{2}} & \sqrt{2} \end{array}$	$\begin{array}{ccc} (11) & (22) & (33) \\ 1 & +1 & +1 \end{array}$	$\begin{array}{cc} (23) & (12) \\ \sqrt{\frac{1}{2}} & \sqrt{2} \end{array}$	$\begin{array}{c} (13) \\ \sqrt{\frac{1}{2}} \end{array}$
$\langle \begin{array}{ c } \hline 13 \\ \hline 2 \\ \hline \end{array} $	$\begin{array}{c} (31) \\ \sqrt{\frac{3}{2}} \end{array}$	$\begin{array}{c} (32) \\ \sqrt{\frac{3}{2}} \end{array}$	\cdot	$\begin{array}{ccc} (11) & (22) & (33) \\ 1 & +1 & +1 \end{array}$	$\begin{array}{cc} (23) & (13) \\ \sqrt{\frac{3}{2}} & \cdot \end{array}$
$\langle \begin{array}{ c } \hline 13 \\ \hline 3 \\ \hline \end{array} $	\cdot	\cdot	$\begin{array}{c} (31) \\ 1 \end{array}$	$\begin{array}{cc} (32) & (32) \\ \sqrt{\frac{1}{2}} & \sqrt{\frac{3}{2}} \end{array}$	$\begin{array}{cc} (11) & (33) \\ 1 & +2 \end{array}$
$\langle \begin{array}{ c } \hline 22 \\ \hline 3 \\ \hline \end{array} $	\cdot	$\begin{array}{c} (31) \\ -1 \end{array}$	\cdot	$\begin{array}{c} (21) \\ \sqrt{2} \end{array}$	$\begin{array}{cc} (22) & (33) \\ 2 & +1 \end{array}$
$\langle \begin{array}{ c } \hline 23 \\ \hline 3 \\ \hline \end{array} $	\cdot	\cdot	\cdot	$\begin{array}{cc} (31) & (31) \\ \sqrt{\frac{1}{2}} & \sqrt{\frac{3}{2}} \end{array}$	$\begin{array}{ccc} (21) & (32) & (22) & (33) \\ 1 & 1 & 1 & +2 \end{array}$

$$L_z \equiv \begin{pmatrix} 1 & \cdot & \cdot \\ \cdot & 0 & \cdot \\ \cdot & \cdot & -1 \end{pmatrix} = (E_{11} - E_{33}) = \sqrt{2} \mathbf{v}_0^1 \text{ dipole } (k=1) \text{ } \angle\text{-momentum } L\text{-operators}$$

$$L_+ \equiv \sqrt{2} \begin{pmatrix} \cdot & 1 & \cdot \\ \cdot & \cdot & 1 \\ \cdot & \cdot & \cdot \end{pmatrix} = \sqrt{2}(E_{12} + E_{23}) = L_x + iL_y = -\sqrt{2} \mathbf{v}_1^1$$

$$L_- \equiv \sqrt{2} \begin{pmatrix} \cdot & \cdot & \cdot \\ 1 & \cdot & \cdot \\ \cdot & 1 & \cdot \end{pmatrix} = \sqrt{2}(E_{21} + E_{32}) = L_x - iL_y = \sqrt{2} \mathbf{v}_{=1}^1$$

$$L_- |^2_1\rangle = \sqrt{(2+1)(2-1+1)} |^2_0\rangle = \sqrt{6} |^2_0\rangle$$

$$\begin{aligned} |^2_0\rangle &= \frac{1}{\sqrt{6}} L_- |^2_1\rangle = \frac{1}{\sqrt{6}} \sqrt{2} (E_{21} + E_{32}) \frac{1}{\sqrt{2}} \left(\begin{array}{|c|} \hline 12 \\ \hline 2 \\ \hline \end{array} \rangle + \begin{array}{|c|} \hline 11 \\ \hline 3 \\ \hline \end{array} \rangle \right) \\ &= \frac{1}{\sqrt{6}} \left(E_{21} \begin{array}{|c|} \hline 12 \\ \hline 2 \\ \hline \end{array} \rangle + E_{21} \begin{array}{|c|} \hline 11 \\ \hline 3 \\ \hline \end{array} \rangle + E_{32} \begin{array}{|c|} \hline 12 \\ \hline 2 \\ \hline \end{array} \rangle + E_{32} \begin{array}{|c|} \hline 11 \\ \hline 3 \\ \hline \end{array} \rangle \right) \\ &= \frac{1}{\sqrt{6}} \left(0 \begin{array}{|c|} \hline 12 \\ \hline 2 \\ \hline \end{array} \rangle + \sqrt{2} \begin{array}{|c|} \hline 12 \\ \hline 3 \\ \hline \end{array} \rangle + \sqrt{\frac{1}{2}} \begin{array}{|c|} \hline 12 \\ \hline 3 \\ \hline \end{array} \rangle + \sqrt{\frac{3}{2}} \begin{array}{|c|} \hline 13 \\ \hline 2 \\ \hline \end{array} \rangle + 0 \begin{array}{|c|} \hline 11 \\ \hline 3 \\ \hline \end{array} \rangle \right) \\ &= \frac{1}{\sqrt{6}} \left(\frac{3}{\sqrt{2}} \begin{array}{|c|} \hline 12 \\ \hline 3 \\ \hline \end{array} \rangle + \sqrt{\frac{3}{2}} \begin{array}{|c|} \hline 13 \\ \hline 2 \\ \hline \end{array} \rangle \right) = \frac{\sqrt{3}}{2} \begin{array}{|c|} \hline 12 \\ \hline 3 \\ \hline \end{array} \rangle + \frac{1}{2} \begin{array}{|c|} \hline 13 \\ \hline 2 \\ \hline \end{array} \rangle = |^2D_{M=0}\rangle = |^2_0\rangle \end{aligned}$$

Orthogonal ($L=1, M=0$) state: $\frac{-1}{2} \begin{array}{|c|} \hline 12 \\ \hline 3 \\ \hline \end{array} \rangle + \frac{\sqrt{3}}{2} \begin{array}{|c|} \hline 13 \\ \hline 2 \\ \hline \end{array} \rangle = |^2P_{M=0}\rangle = |^1_0\rangle$

$$L_- |^2_0\rangle = \sqrt{(2+0)(2-0+1)} |^2_{-1}\rangle = \sqrt{6} |^2_{-1}\rangle$$

$$|^2_{-1}\rangle = \frac{1}{\sqrt{6}} L_- |^2_0\rangle = \frac{1}{\sqrt{6}} \sqrt{2} (E_{21} + E_{32}) \left(\frac{\sqrt{3}}{2} \begin{array}{|c|} \hline 12 \\ \hline 3 \\ \hline \end{array} \rangle + \frac{1}{2} \begin{array}{|c|} \hline 13 \\ \hline 2 \\ \hline \end{array} \rangle \right)$$

$$L_- |^L_M\rangle = \sqrt{(L+M)(L-M+1)} |^L_{M-1}\rangle$$

$$L_- |^2_2\rangle = \sqrt{(2+2)(2-2+1)} |^2_1\rangle = 2 |^2_1\rangle$$

$$|^2_1\rangle = \frac{1}{2} L_- |^2_2\rangle = \frac{1}{2} \sqrt{2} (E_{21} + E_{32}) \begin{array}{|c|} \hline 11 \\ \hline 2 \\ \hline \end{array} \rangle = \frac{1}{\sqrt{2}} \begin{array}{|c|} \hline 12 \\ \hline 2 \\ \hline \end{array} \rangle + \frac{1}{\sqrt{2}} \begin{array}{|c|} \hline 11 \\ \hline 3 \\ \hline \end{array} \rangle = |^2D_{M=1}\rangle$$

Orthogonal $M=1$ state: $|^2P_{M=1}\rangle = |^1_1\rangle = \frac{1}{\sqrt{2}} \begin{array}{|c|} \hline 12 \\ \hline 2 \\ \hline \end{array} \rangle - \frac{1}{\sqrt{2}} \begin{array}{|c|} \hline 11 \\ \hline 3 \\ \hline \end{array} \rangle = |^2P_{M=1}\rangle$

Start with top $[2,1]$ -state:

$$|^2_2\rangle = \begin{array}{|c|} \hline 11 \\ \hline 2 \\ \hline \end{array} \rangle = |^2D_{M=2}\rangle$$

$\square\square = [2,1]$ tableau states lowered by $L_- = \sqrt{2}(E_{21} + E_{32})$

	$M=2$	$M=1$	$M=0$	$M=-1$	$M=-2$			
E_{jk}	$\begin{array}{ c } \hline 11 \\ \hline 2 \\ \hline \end{array}$	$\begin{array}{ c } \hline 12 \\ \hline 2 \\ \hline \end{array}$	$\begin{array}{ c } \hline 11 \\ \hline 3 \\ \hline \end{array}$	$\begin{array}{ c } \hline 12 \\ \hline 3 \\ \hline \end{array}$	$\begin{array}{ c } \hline 13 \\ \hline 2 \\ \hline \end{array}$	$\begin{array}{ c } \hline 13 \\ \hline 3 \\ \hline \end{array}$	$\begin{array}{ c } \hline 22 \\ \hline 3 \\ \hline \end{array}$	$\begin{array}{ c } \hline 23 \\ \hline 3 \\ \hline \end{array}$
$\langle \begin{array}{ c } \hline 11 \\ \hline 2 \\ \hline \end{array} $	$\begin{array}{cc} (11) & (22) \\ 2 & +1 \end{array}$	$\begin{array}{cc} (12) & (23) \\ 1 & 1 \end{array}$	$\begin{array}{cc} (13) & (13) \\ -\sqrt{\frac{1}{2}} & \sqrt{\frac{3}{2}} \end{array}$	\cdot	\cdot	\cdot	\cdot	\cdot
$\langle \begin{array}{ c } \hline 12 \\ \hline 2 \\ \hline \end{array} $	$\begin{array}{cc} (21) & \\ 1 & \end{array}$	$\begin{array}{cc} (11) & (22) \\ 1 & +2 \end{array}$	$\begin{array}{cc} (23) & (23) \\ \sqrt{\frac{1}{2}} & \sqrt{\frac{3}{2}} \end{array}$	\cdot	$\begin{array}{cc} (13) & \\ & -1 \end{array}$	\cdot	\cdot	\cdot
$\langle \begin{array}{ c } \hline 11 \\ \hline 3 \\ \hline \end{array} $	$\begin{array}{cc} (32) & \\ 1 & \end{array}$	\cdot	$\begin{array}{cc} (11) & (33) \\ & 2+1 \end{array}$	$\begin{array}{cc} (12) & \\ \sqrt{2} & \end{array}$	\cdot	$\begin{array}{cc} (13) & \\ 1 & \end{array}$	\cdot	\cdot
$\langle \begin{array}{ c } \hline 12 \\ \hline 3 \\ \hline \end{array} $	$\begin{array}{cc} (31) & \\ -\sqrt{\frac{1}{2}} & \end{array}$	$\begin{array}{cc} (32) & (21) \\ \sqrt{\frac{1}{2}} & \sqrt{2} \end{array}$	$\begin{array}{ccc} (11) & (22) & (33) \\ 1 & +1 & +1 \end{array}$	\cdot	$\begin{array}{cc} (23) & (12) \\ \sqrt{\frac{1}{2}} & \sqrt{2} \end{array}$	$\begin{array}{cc} (13) & \\ \sqrt{\frac{1}{2}} & \end{array}$	$\begin{array}{cc} (12) & \\ \sqrt{2} & \end{array}$	$\begin{array}{cc} (13) & \\ \sqrt{\frac{1}{2}} & \end{array}$
$\langle \begin{array}{ c } \hline 13 \\ \hline 2 \\ \hline \end{array} $	$\begin{array}{cc} (31) & \\ \sqrt{\frac{3}{2}} & \end{array}$	$\begin{array}{cc} (32) & \\ \sqrt{\frac{3}{2}} & \end{array}$	\cdot	$\begin{array}{ccc} (11) & (22) & (33) \\ & 1 & +1 & +1 \end{array}$	\cdot	$\begin{array}{cc} (23) & \\ \sqrt{\frac{3}{2}} & \end{array}$	\cdot	$\begin{array}{cc} (13) & \\ \sqrt{\frac{3}{2}} & \end{array}$
$\langle \begin{array}{ c } \hline 13 \\ \hline 3 \\ \hline \end{array} $	\cdot	\cdot	$\begin{array}{cc} (31) & \\ 1 & \end{array}$	$\begin{array}{cc} (32) & \\ \sqrt{\frac{1}{2}} & \end{array}$	$\begin{array}{cc} (32) & \\ \sqrt{\frac{3}{2}} & \end{array}$	$\begin{array}{cc} (11) & (33) \\ 1 & +2 \end{array}$	\cdot	$\begin{array}{cc} (12) & \\ 1 & \end{array}$
$\langle \begin{array}{ c } \hline 22 \\ \hline 3 \\ \hline \end{array} $	\cdot	$\begin{array}{cc} (31) & \\ -1 & \end{array}$	\cdot	$\begin{array}{cc} (21) & \\ \sqrt{2} & \end{array}$	\cdot	$\begin{array}{cc} (22) & (33) \\ & 2+1 \end{array}$	$\begin{array}{cc} (23) & \\ 1 & \end{array}$	$\begin{array}{cc} (23) & \\ 1 & \end{array}$
$\langle \begin{array}{ c } \hline 23 \\ \hline 3 \\ \hline \end{array} $	\cdot	\cdot	\cdot	$\begin{array}{cc} (31) & \\ \sqrt{\frac{1}{2}} & \end{array}$	$\begin{array}{cc} (31) & \\ \sqrt{\frac{3}{2}} & \end{array}$	$\begin{array}{cc} (21) & (32) \\ 1 & 1 \end{array}$	$\begin{array}{cc} (22) & (33) \\ 1 & +2 \end{array}$	$\begin{array}{cc} (22) & (33) \\ 1 & +2 \end{array}$

$L_z \equiv \begin{pmatrix} 1 & \cdot & \cdot \\ \cdot & 0 & \cdot \\ \cdot & \cdot & -1 \end{pmatrix} = (E_{11} - E_{33}) = \sqrt{2} \mathbf{v}_0^1$ dipole ($k=1$)
 \angle -momentum
 L -operators

$L_+ \equiv \sqrt{2} \begin{pmatrix} \cdot & 1 & \cdot \\ \cdot & \cdot & 1 \\ \cdot & \cdot & \cdot \end{pmatrix} = \sqrt{2}(E_{12} + E_{23}) = L_x + iL_y = -\sqrt{2} \mathbf{v}_1^1$

$L_- \equiv \sqrt{2} \begin{pmatrix} \cdot & \cdot & \cdot \\ 1 & \cdot & \cdot \\ \cdot & 1 & \cdot \end{pmatrix} = \sqrt{2}(E_{21} + E_{32}) = L_x - iL_y = \sqrt{2} \mathbf{v}_{-1}^1$

$L_- |^2_1\rangle = \sqrt{(2+1)(2-1+1)} |^2_0\rangle = \sqrt{6} |^2_0\rangle$
 $|^2_0\rangle = \frac{1}{\sqrt{6}} L_- |^2_1\rangle = \frac{1}{\sqrt{6}} \sqrt{2} (E_{21} + E_{32}) \frac{1}{\sqrt{2}} \left(\begin{array}{|c|} \hline 12 \\ \hline 2 \\ \hline \end{array} \rangle + \begin{array}{|c|} \hline 11 \\ \hline 3 \\ \hline \end{array} \rangle \right)$
 $= \frac{1}{\sqrt{6}} \left(E_{21} \begin{array}{|c|} \hline 12 \\ \hline 2 \\ \hline \end{array} \rangle + E_{21} \begin{array}{|c|} \hline 11 \\ \hline 3 \\ \hline \end{array} \rangle + E_{32} \begin{array}{|c|} \hline 12 \\ \hline 2 \\ \hline \end{array} \rangle + E_{32} \begin{array}{|c|} \hline 11 \\ \hline 3 \\ \hline \end{array} \rangle \right)$
 $= \frac{1}{\sqrt{6}} \left(0 \begin{array}{|c|} \hline 12 \\ \hline 2 \\ \hline \end{array} \rangle + \sqrt{2} \begin{array}{|c|} \hline 11 \\ \hline 3 \\ \hline \end{array} \rangle + \sqrt{\frac{1}{2}} \begin{array}{|c|} \hline 12 \\ \hline 3 \\ \hline \end{array} \rangle + \sqrt{\frac{3}{2}} \begin{array}{|c|} \hline 11 \\ \hline 2 \\ \hline \end{array} \rangle + 0 \begin{array}{|c|} \hline 11 \\ \hline 3 \\ \hline \end{array} \rangle \right)$
 $= \frac{1}{\sqrt{6}} \left(\frac{3}{\sqrt{2}} \begin{array}{|c|} \hline 11 \\ \hline 3 \\ \hline \end{array} \rangle + \sqrt{\frac{3}{2}} \begin{array}{|c|} \hline 11 \\ \hline 2 \\ \hline \end{array} \rangle \right) = \frac{\sqrt{3}}{2} \begin{array}{|c|} \hline 11 \\ \hline 3 \\ \hline \end{array} \rangle + \frac{1}{2} \begin{array}{|c|} \hline 11 \\ \hline 2 \\ \hline \end{array} \rangle = |^2D_{M=0}\rangle = |^2_0\rangle$

Orthogonal ($L=1, M=0$) state: $\frac{-1}{2} \begin{array}{|c|} \hline 11 \\ \hline 3 \\ \hline \end{array} \rangle + \frac{\sqrt{3}}{2} \begin{array}{|c|} \hline 11 \\ \hline 2 \\ \hline \end{array} \rangle = |^2P_{M=0}\rangle = |^1_0\rangle$

$L_- |^2_0\rangle = \sqrt{(2+0)(2-0+1)} |^2_{-1}\rangle = \sqrt{6} |^2_{-1}\rangle$
 $|^2_{-1}\rangle = \frac{1}{\sqrt{6}} L_- |^2_0\rangle = \frac{1}{\sqrt{6}} \sqrt{2} (E_{21} + E_{32}) \left(\frac{\sqrt{3}}{2} \begin{array}{|c|} \hline 11 \\ \hline 3 \\ \hline \end{array} \rangle + \frac{1}{2} \begin{array}{|c|} \hline 11 \\ \hline 2 \\ \hline \end{array} \rangle \right)$
 $= \frac{1}{\sqrt{3}} \left(\frac{\sqrt{3}}{2} E_{21} \begin{array}{|c|} \hline 11 \\ \hline 3 \\ \hline \end{array} \rangle + \frac{1}{2} E_{21} \begin{array}{|c|} \hline 11 \\ \hline 2 \\ \hline \end{array} \rangle + \frac{\sqrt{3}}{2} E_{32} \begin{array}{|c|} \hline 11 \\ \hline 3 \\ \hline \end{array} \rangle + \frac{1}{2} E_{32} \begin{array}{|c|} \hline 11 \\ \hline 2 \\ \hline \end{array} \rangle \right)$

$L_- |^L_M\rangle = \sqrt{(L+M)(L-M+1)} |^L_{M-1}\rangle$
 $L_- |^2_2\rangle = \sqrt{(2+2)(2-2+1)} |^2_1\rangle = 2 |^2_1\rangle$
 $|^2_1\rangle = \frac{1}{2} L_- |^2_2\rangle = \frac{1}{2} \sqrt{2} (E_{21} + E_{32}) \begin{array}{|c|} \hline 11 \\ \hline 2 \\ \hline \end{array} \rangle = \frac{1}{\sqrt{2}} \begin{array}{|c|} \hline 11 \\ \hline 2 \\ \hline \end{array} \rangle + \frac{1}{\sqrt{2}} \begin{array}{|c|} \hline 11 \\ \hline 3 \\ \hline \end{array} \rangle = |^2D_{M=1}\rangle$
 Start with top $[2,1]$ -state:
 $|^2_2\rangle = \begin{array}{|c|} \hline 11 \\ \hline 2 \\ \hline \end{array} \rangle = |^2D_{M=2}\rangle$
 Orthogonal $M=1$ state: $|^2P_{M=1}\rangle = |^1_1\rangle = \frac{1}{\sqrt{2}} \begin{array}{|c|} \hline 11 \\ \hline 2 \\ \hline \end{array} \rangle - \frac{1}{\sqrt{2}} \begin{array}{|c|} \hline 11 \\ \hline 3 \\ \hline \end{array} \rangle = |^2P_{M=1}\rangle$

$\square\square = [2,1]$ tableau states lowered by $L_- = \sqrt{2}(E_{21} + E_{32})$

	$M=2$	$M=1$	$M=0$	$M=-1$	$M=-2$			
E_{jk}	$\begin{array}{ c } \hline 11 \\ \hline 2 \\ \hline \end{array}$	$\begin{array}{ c } \hline 12 \\ \hline 2 \\ \hline \end{array}$	$\begin{array}{ c } \hline 11 \\ \hline 3 \\ \hline \end{array}$	$\begin{array}{ c } \hline 12 \\ \hline 3 \\ \hline \end{array}$	$\begin{array}{ c } \hline 13 \\ \hline 2 \\ \hline \end{array}$	$\begin{array}{ c } \hline 13 \\ \hline 3 \\ \hline \end{array}$	$\begin{array}{ c } \hline 22 \\ \hline 3 \\ \hline \end{array}$	$\begin{array}{ c } \hline 23 \\ \hline 3 \\ \hline \end{array}$
$\langle \begin{array}{ c } \hline 11 \\ \hline 2 \\ \hline \end{array} $	$\begin{array}{cc} (11) & (22) \\ 2 & +1 \end{array}$	$\begin{array}{cc} (12) & (23) \\ 1 & 1 \end{array}$	$\begin{array}{cc} (13) & (13) \\ -\sqrt{\frac{1}{2}} & \sqrt{\frac{3}{2}} \end{array}$	\cdot	\cdot	\cdot	\cdot	\cdot
$\langle \begin{array}{ c } \hline 12 \\ \hline 2 \\ \hline \end{array} $	$\begin{array}{cc} (21) \\ 1 \end{array}$	$\begin{array}{cc} (11) & (22) \\ 1 & +2 \end{array}$	$\begin{array}{cc} (23) \\ \sqrt{\frac{1}{2}} \end{array}$	$\begin{array}{cc} (23) \\ \sqrt{\frac{3}{2}} \end{array}$	\cdot	$\begin{array}{cc} (13) \\ -1 \end{array}$	\cdot	\cdot
$\langle \begin{array}{ c } \hline 11 \\ \hline 3 \\ \hline \end{array} $	$\begin{array}{cc} (32) \\ 1 \end{array}$	\cdot	$\begin{array}{cc} (11) & (33) \\ 2 & +1 \end{array}$	$\begin{array}{cc} (12) \\ \sqrt{2} \end{array}$	\cdot	$\begin{array}{cc} (13) \\ 1 \end{array}$	\cdot	\cdot
$\langle \begin{array}{ c } \hline 12 \\ \hline 3 \\ \hline \end{array} $	$\begin{array}{cc} (31) \\ -\sqrt{\frac{1}{2}} \end{array}$	$\begin{array}{cc} (32) \\ \sqrt{\frac{1}{2}} \end{array}$	$\begin{array}{cc} (21) \\ \sqrt{2} \end{array}$	$\begin{array}{ccc} (11) & (22) & (33) \\ 1 & +1 & +1 \end{array}$	\cdot	$\begin{array}{cc} (23) \\ \sqrt{\frac{1}{2}} \end{array}$	$\begin{array}{cc} (12) \\ \sqrt{2} \end{array}$	$\begin{array}{cc} (13) \\ \sqrt{\frac{1}{2}} \end{array}$
$\langle \begin{array}{ c } \hline 13 \\ \hline 2 \\ \hline \end{array} $	$\begin{array}{cc} (31) \\ \sqrt{\frac{3}{2}} \end{array}$	$\begin{array}{cc} (32) \\ \sqrt{\frac{3}{2}} \end{array}$	\cdot	$\begin{array}{ccc} (11) & (22) & (33) \\ 1 & +1 & +1 \end{array}$	\cdot	$\begin{array}{cc} (23) \\ \sqrt{\frac{3}{2}} \end{array}$	\cdot	$\begin{array}{cc} (13) \\ \sqrt{\frac{3}{2}} \end{array}$
$\langle \begin{array}{ c } \hline 13 \\ \hline 3 \\ \hline \end{array} $	\cdot	\cdot	$\begin{array}{cc} (31) \\ 1 \end{array}$	$\begin{array}{cc} (32) \\ \sqrt{\frac{1}{2}} \end{array}$	$\begin{array}{cc} (32) \\ \sqrt{\frac{3}{2}} \end{array}$	$\begin{array}{cc} (11) & (33) \\ 1 & +2 \end{array}$	\cdot	$\begin{array}{cc} (12) \\ 1 \end{array}$
$\langle \begin{array}{ c } \hline 22 \\ \hline 3 \\ \hline \end{array} $	\cdot	$\begin{array}{cc} (31) \\ -1 \end{array}$	\cdot	$\begin{array}{cc} (21) \\ \sqrt{2} \end{array}$	\cdot	$\begin{array}{cc} (22) & (33) \\ 2 & +1 \end{array}$	$\begin{array}{cc} (23) \\ 1 \end{array}$	\cdot
$\langle \begin{array}{ c } \hline 23 \\ \hline 3 \\ \hline \end{array} $	\cdot	\cdot	\cdot	$\begin{array}{cc} (31) \\ \sqrt{\frac{1}{2}} \end{array}$	$\begin{array}{cc} (31) \\ \sqrt{\frac{3}{2}} \end{array}$	$\begin{array}{cc} (21) & (32) \\ 1 & 1 \end{array}$	$\begin{array}{cc} (22) & (33) \\ 1 & +2 \end{array}$	\cdot

$L_z \equiv \begin{pmatrix} 1 & \cdot & \cdot \\ \cdot & 0 & \cdot \\ \cdot & \cdot & -1 \end{pmatrix} = (E_{11} - E_{33}) = \sqrt{2} \mathbf{v}_0^1$ dipole ($k=1$)
 \angle -momentum
 L -operators

$L_+ \equiv \sqrt{2} \begin{pmatrix} \cdot & 1 & \cdot \\ \cdot & \cdot & 1 \\ \cdot & \cdot & \cdot \end{pmatrix} = \sqrt{2}(E_{12} + E_{23}) = L_x + iL_y = -\sqrt{2} \mathbf{v}_1^1$

$L_- \equiv \sqrt{2} \begin{pmatrix} \cdot & \cdot & \cdot \\ 1 & \cdot & \cdot \\ \cdot & 1 & \cdot \end{pmatrix} = \sqrt{2}(E_{21} + E_{32}) = L_x - iL_y = \sqrt{2} \mathbf{v}_{-1}^1$

$L_- |^2_1\rangle = \sqrt{(2+1)(2-1+1)} |^2_0\rangle = \sqrt{6} |^2_0\rangle$
 $|^2_0\rangle = \frac{1}{\sqrt{6}} L_- |^2_1\rangle = \frac{1}{\sqrt{6}} \sqrt{2} (E_{21} + E_{32}) \frac{1}{\sqrt{2}} \left(\begin{array}{|c|} \hline 12 \\ \hline 2 \\ \hline \end{array} \rangle + \begin{array}{|c|} \hline 11 \\ \hline 3 \\ \hline \end{array} \rangle \right)$
 $= \frac{1}{\sqrt{6}} \left(E_{21} \begin{array}{|c|} \hline 12 \\ \hline 2 \\ \hline \end{array} \rangle + E_{21} \begin{array}{|c|} \hline 11 \\ \hline 3 \\ \hline \end{array} \rangle + E_{32} \begin{array}{|c|} \hline 12 \\ \hline 2 \\ \hline \end{array} \rangle + E_{32} \begin{array}{|c|} \hline 11 \\ \hline 3 \\ \hline \end{array} \rangle \right)$
 $= \frac{1}{\sqrt{6}} \left(0 \begin{array}{|c|} \hline 12 \\ \hline 2 \\ \hline \end{array} \rangle + \sqrt{2} \begin{array}{|c|} \hline 11 \\ \hline 3 \\ \hline \end{array} \rangle + \sqrt{\frac{1}{2}} \begin{array}{|c|} \hline 12 \\ \hline 3 \\ \hline \end{array} \rangle + \sqrt{\frac{3}{2}} \begin{array}{|c|} \hline 11 \\ \hline 2 \\ \hline \end{array} \rangle + 0 \begin{array}{|c|} \hline 11 \\ \hline 3 \\ \hline \end{array} \rangle \right)$
 $= \frac{1}{\sqrt{6}} \left(\frac{3}{\sqrt{2}} \begin{array}{|c|} \hline 11 \\ \hline 3 \\ \hline \end{array} \rangle + \sqrt{\frac{3}{2}} \begin{array}{|c|} \hline 11 \\ \hline 2 \\ \hline \end{array} \rangle \right) = \frac{\sqrt{3}}{2} \begin{array}{|c|} \hline 11 \\ \hline 3 \\ \hline \end{array} \rangle + \frac{1}{2} \begin{array}{|c|} \hline 11 \\ \hline 2 \\ \hline \end{array} \rangle = |^2D_{M=0}\rangle = |^2_0\rangle$

Orthogonal ($L=1, M=0$) state: $\frac{-1}{2} \begin{array}{|c|} \hline 11 \\ \hline 3 \\ \hline \end{array} \rangle + \frac{\sqrt{3}}{2} \begin{array}{|c|} \hline 11 \\ \hline 2 \\ \hline \end{array} \rangle = |^2P_{M=0}\rangle = |^1_0\rangle$

$L_- |^2_0\rangle = \sqrt{(2+0)(2-0+1)} |^2_{-1}\rangle = \sqrt{6} |^2_{-1}\rangle$
 $|^2_{-1}\rangle = \frac{1}{\sqrt{6}} L_- |^2_0\rangle = \frac{1}{\sqrt{6}} \sqrt{2} (E_{21} + E_{32}) \left(\frac{\sqrt{3}}{2} \begin{array}{|c|} \hline 11 \\ \hline 3 \\ \hline \end{array} \rangle + \frac{1}{2} \begin{array}{|c|} \hline 11 \\ \hline 2 \\ \hline \end{array} \rangle \right)$
 $= \frac{1}{\sqrt{3}} \left(\frac{\sqrt{3}}{2} E_{21} \begin{array}{|c|} \hline 11 \\ \hline 3 \\ \hline \end{array} \rangle + \frac{1}{2} E_{21} \begin{array}{|c|} \hline 11 \\ \hline 2 \\ \hline \end{array} \rangle + \frac{\sqrt{3}}{2} E_{32} \begin{array}{|c|} \hline 11 \\ \hline 3 \\ \hline \end{array} \rangle + \frac{1}{2} E_{32} \begin{array}{|c|} \hline 11 \\ \hline 2 \\ \hline \end{array} \rangle \right)$
 $= \frac{1}{\sqrt{3}} \left(\frac{\sqrt{3}}{2} \frac{\sqrt{2}}{1} \begin{array}{|c|} \hline 22 \\ \hline 3 \\ \hline \end{array} \rangle + 0 \begin{array}{|c|} \hline 22 \\ \hline 2 \\ \hline \end{array} \rangle + \frac{\sqrt{3}}{2} \sqrt{\frac{1}{2}} \begin{array}{|c|} \hline 11 \\ \hline 3 \\ \hline \end{array} \rangle + \frac{1}{2} \sqrt{\frac{3}{2}} \begin{array}{|c|} \hline 11 \\ \hline 3 \\ \hline \end{array} \rangle \right)$

$L_- |^L_M\rangle = \sqrt{(L+M)(L-M+1)} |^L_{M-1}\rangle$
 $L_- |^2_2\rangle = \sqrt{(2+2)(2-2+1)} |^2_1\rangle = 2 |^2_1\rangle$
 $|^2_1\rangle = \frac{1}{2} L_- |^2_2\rangle = \frac{1}{2} \sqrt{2} (E_{21} + E_{32}) \begin{array}{|c|} \hline 11 \\ \hline 2 \\ \hline \end{array} \rangle = \frac{1}{\sqrt{2}} \begin{array}{|c|} \hline 11 \\ \hline 2 \\ \hline \end{array} \rangle + \frac{1}{\sqrt{2}} \begin{array}{|c|} \hline 11 \\ \hline 3 \\ \hline \end{array} \rangle = |^2D_{M=1}\rangle$
 Orthogonal $M=1$ state: $|^2P_{M=1}\rangle = |^1_1\rangle = \frac{1}{\sqrt{2}} \begin{array}{|c|} \hline 11 \\ \hline 2 \\ \hline \end{array} \rangle - \frac{1}{\sqrt{2}} \begin{array}{|c|} \hline 11 \\ \hline 3 \\ \hline \end{array} \rangle = |^2P_{M=1}\rangle$

Start with top $[2,1]$ -state:

$|^2_2\rangle = \begin{array}{|c|} \hline 11 \\ \hline 2 \\ \hline \end{array} \rangle = |^2D_{M=2}\rangle$

$\square\square = [2,1]$ tableau states lowered by $L_- = \sqrt{2}(E_{21} + E_{32})$

	$M=2$	$M=1$	$M=0$	$M=-1$	$M=-2$			
E_{jk}	$\begin{array}{ c } \hline 11 \\ \hline 2 \\ \hline \end{array}$	$\begin{array}{ c } \hline 12 \\ \hline 2 \\ \hline \end{array}$	$\begin{array}{ c } \hline 11 \\ \hline 3 \\ \hline \end{array}$	$\begin{array}{ c } \hline 12 \\ \hline 3 \\ \hline \end{array}$	$\begin{array}{ c } \hline 13 \\ \hline 2 \\ \hline \end{array}$	$\begin{array}{ c } \hline 13 \\ \hline 3 \\ \hline \end{array}$	$\begin{array}{ c } \hline 22 \\ \hline 3 \\ \hline \end{array}$	$\begin{array}{ c } \hline 23 \\ \hline 3 \\ \hline \end{array}$
$\langle \begin{array}{ c } \hline 11 \\ \hline 2 \\ \hline \end{array} $	$\begin{array}{cc} (11) & (22) \\ 2 & +1 \end{array}$	$\begin{array}{cc} (12) & (23) \\ 1 & 1 \end{array}$	$\begin{array}{cc} (13) & (13) \\ -\sqrt{\frac{1}{2}} & \sqrt{\frac{3}{2}} \end{array}$	\cdot	\cdot	\cdot	\cdot	\cdot
$\langle \begin{array}{ c } \hline 12 \\ \hline 2 \\ \hline \end{array} $	$\begin{array}{cc} (21) \\ 1 \end{array}$	$\begin{array}{cc} (11) & (22) \\ 1 & +2 \end{array}$	$\begin{array}{cc} (23) & (23) \\ \sqrt{\frac{1}{2}} & \sqrt{\frac{3}{2}} \end{array}$	\cdot	$\begin{array}{cc} (13) \\ -1 \end{array}$	\cdot	\cdot	\cdot
$\langle \begin{array}{ c } \hline 11 \\ \hline 3 \\ \hline \end{array} $	$\begin{array}{cc} (32) \\ 1 \end{array}$	\cdot	$\begin{array}{cc} (11) & (33) \\ 2 & +1 \end{array}$	$\begin{array}{cc} (12) \\ \sqrt{2} \end{array}$	\cdot	$\begin{array}{cc} (13) \\ 1 \end{array}$	\cdot	\cdot
$\langle \begin{array}{ c } \hline 12 \\ \hline 3 \\ \hline \end{array} $	$\begin{array}{cc} (31) \\ -\sqrt{\frac{1}{2}} \end{array}$	$\begin{array}{cc} (32) \\ \sqrt{\frac{1}{2}} \end{array}$	$\begin{array}{cc} (21) \\ \sqrt{2} \end{array}$	$\begin{array}{ccc} (11) & (22) & (33) \\ 1 & +1 & +1 \end{array}$	\cdot	$\begin{array}{cc} (23) & (12) \\ \sqrt{\frac{1}{2}} & \sqrt{2} \end{array}$	$\begin{array}{cc} (13) \\ \sqrt{\frac{1}{2}} \end{array}$	$\begin{array}{cc} (13) \\ \sqrt{\frac{1}{2}} \end{array}$
$\langle \begin{array}{ c } \hline 13 \\ \hline 2 \\ \hline \end{array} $	$\begin{array}{cc} (31) \\ \sqrt{\frac{3}{2}} \end{array}$	$\begin{array}{cc} (32) \\ \sqrt{\frac{3}{2}} \end{array}$	\cdot	$\begin{array}{ccc} (11) & (22) & (33) \\ 1 & +1 & +1 \end{array}$	\cdot	$\begin{array}{cc} (23) \\ \sqrt{\frac{3}{2}} \end{array}$	\cdot	$\begin{array}{cc} (13) \\ \sqrt{\frac{3}{2}} \end{array}$
$\langle \begin{array}{ c } \hline 13 \\ \hline 3 \\ \hline \end{array} $	\cdot	\cdot	$\begin{array}{cc} (31) \\ 1 \end{array}$	$\begin{array}{cc} (32) \\ \sqrt{\frac{1}{2}} \end{array}$	$\begin{array}{cc} (32) \\ \sqrt{\frac{3}{2}} \end{array}$	$\begin{array}{cc} (11) & (33) \\ 1 & +2 \end{array}$	\cdot	$\begin{array}{cc} (12) \\ 1 \end{array}$
$\langle \begin{array}{ c } \hline 22 \\ \hline 3 \\ \hline \end{array} $	\cdot	$\begin{array}{cc} (31) \\ -1 \end{array}$	\cdot	$\begin{array}{cc} (21) \\ \sqrt{2} \end{array}$	\cdot	$\begin{array}{cc} (22) & (33) \\ 2 & +1 \end{array}$	$\begin{array}{cc} (23) \\ 1 \end{array}$	$\begin{array}{cc} (23) \\ 1 \end{array}$
$\langle \begin{array}{ c } \hline 23 \\ \hline 3 \\ \hline \end{array} $	\cdot	\cdot	\cdot	$\begin{array}{cc} (31) \\ \sqrt{\frac{1}{2}} \end{array}$	$\begin{array}{cc} (31) \\ \sqrt{\frac{3}{2}} \end{array}$	$\begin{array}{cc} (21) & (32) \\ 1 & 1 \end{array}$	$\begin{array}{cc} (22) & (33) \\ 1 & +2 \end{array}$	$\begin{array}{cc} (22) & (33) \\ 1 & +2 \end{array}$

$$L_z \equiv \begin{pmatrix} 1 & \cdot & \cdot \\ \cdot & 0 & \cdot \\ \cdot & \cdot & -1 \end{pmatrix} = (E_{11} - E_{33}) = \sqrt{2} \mathbf{v}_0^1 \text{ dipole } (k=1) \text{ } \angle\text{-momentum } L\text{-operators}$$

$$L_+ \equiv \sqrt{2} \begin{pmatrix} \cdot & 1 & \cdot \\ \cdot & \cdot & 1 \\ \cdot & \cdot & \cdot \end{pmatrix} = \sqrt{2}(E_{12} + E_{23}) = L_x + iL_y = -\sqrt{2} \mathbf{v}_1^1$$

$$L_- \equiv \sqrt{2} \begin{pmatrix} \cdot & \cdot & \cdot \\ 1 & \cdot & \cdot \\ \cdot & 1 & \cdot \end{pmatrix} = \sqrt{2}(E_{21} + E_{32}) = L_x - iL_y = \sqrt{2} \mathbf{v}_{-1}^1$$

$$L_- |^2_1\rangle = \sqrt{(2+1)(2-1+1)} |^2_0\rangle = \sqrt{6} |^2_0\rangle$$

$$|^2_0\rangle = \frac{1}{\sqrt{6}} L_- |^2_1\rangle = \frac{1}{\sqrt{6}} \sqrt{2} (E_{21} + E_{32}) \frac{1}{\sqrt{2}} \left(\begin{array}{|c|} \hline 12 \\ \hline 2 \\ \hline \end{array} \rangle + \begin{array}{|c|} \hline 11 \\ \hline 3 \\ \hline \end{array} \rangle \right)$$

$$= \frac{1}{\sqrt{6}} \left(E_{21} \begin{array}{|c|} \hline 12 \\ \hline 2 \\ \hline \end{array} \rangle + E_{21} \begin{array}{|c|} \hline 11 \\ \hline 3 \\ \hline \end{array} \rangle + E_{32} \begin{array}{|c|} \hline 12 \\ \hline 2 \\ \hline \end{array} \rangle + E_{32} \begin{array}{|c|} \hline 11 \\ \hline 3 \\ \hline \end{array} \rangle \right)$$

$$= \frac{1}{\sqrt{6}} \left(0 \begin{array}{|c|} \hline 12 \\ \hline 2 \\ \hline \end{array} \rangle + \sqrt{2} \begin{array}{|c|} \hline 11 \\ \hline 3 \\ \hline \end{array} \rangle + \sqrt{\frac{1}{2}} \begin{array}{|c|} \hline 12 \\ \hline 3 \\ \hline \end{array} \rangle + \sqrt{\frac{3}{2}} \begin{array}{|c|} \hline 11 \\ \hline 2 \\ \hline \end{array} \rangle + 0 \begin{array}{|c|} \hline 11 \\ \hline 3 \\ \hline \end{array} \rangle \right)$$

$$= \frac{1}{\sqrt{6}} \left(\frac{3}{\sqrt{2}} \begin{array}{|c|} \hline 11 \\ \hline 3 \\ \hline \end{array} \rangle + \sqrt{\frac{3}{2}} \begin{array}{|c|} \hline 11 \\ \hline 2 \\ \hline \end{array} \rangle \right) = \frac{\sqrt{3}}{2} \begin{array}{|c|} \hline 11 \\ \hline 3 \\ \hline \end{array} \rangle + \frac{1}{2} \begin{array}{|c|} \hline 11 \\ \hline 2 \\ \hline \end{array} \rangle = |^2D_{M=0}\rangle = |^2_0\rangle$$

Orthogonal ($L=1, M=0$) state: $\frac{-1}{2} \begin{array}{|c|} \hline 11 \\ \hline 3 \\ \hline \end{array} \rangle + \frac{\sqrt{3}}{2} \begin{array}{|c|} \hline 11 \\ \hline 2 \\ \hline \end{array} \rangle = |^2P_{M=0}\rangle = |^1_0\rangle$

$$L_- |^2_0\rangle = \sqrt{(2+0)(2-0+1)} |^2_{-1}\rangle = \sqrt{6} |^2_{-1}\rangle$$

$$|^2_{-1}\rangle = \frac{1}{\sqrt{6}} L_- |^2_0\rangle = \frac{1}{\sqrt{6}} \sqrt{2} (E_{21} + E_{32}) \left(\frac{\sqrt{3}}{2} \begin{array}{|c|} \hline 11 \\ \hline 3 \\ \hline \end{array} \rangle + \frac{1}{2} \begin{array}{|c|} \hline 11 \\ \hline 2 \\ \hline \end{array} \rangle \right)$$

$$= \frac{1}{\sqrt{3}} \left(\frac{\sqrt{3}}{2} E_{21} \begin{array}{|c|} \hline 11 \\ \hline 3 \\ \hline \end{array} \rangle + \frac{1}{2} E_{21} \begin{array}{|c|} \hline 11 \\ \hline 2 \\ \hline \end{array} \rangle + \frac{\sqrt{3}}{2} E_{32} \begin{array}{|c|} \hline 11 \\ \hline 3 \\ \hline \end{array} \rangle + \frac{1}{2} E_{32} \begin{array}{|c|} \hline 11 \\ \hline 2 \\ \hline \end{array} \rangle \right)$$

$$= \frac{1}{\sqrt{3}} \left(\frac{\sqrt{3}}{2} \sqrt{\frac{2}{1}} \begin{array}{|c|} \hline 22 \\ \hline 3 \\ \hline \end{array} \rangle + 0 \begin{array}{|c|} \hline 22 \\ \hline 2 \\ \hline \end{array} \rangle + \frac{\sqrt{3}}{2} \sqrt{\frac{1}{2}} \begin{array}{|c|} \hline 13 \\ \hline 3 \\ \hline \end{array} \rangle + \frac{1}{2} \sqrt{\frac{3}{2}} \begin{array}{|c|} \hline 13 \\ \hline 3 \\ \hline \end{array} \rangle \right)$$

$$= \frac{1}{\sqrt{3}} \left(\sqrt{\frac{3}{2}} \begin{array}{|c|} \hline 22 \\ \hline 3 \\ \hline \end{array} \rangle + \sqrt{\frac{3}{2}} \begin{array}{|c|} \hline 13 \\ \hline 3 \\ \hline \end{array} \rangle \right) = \frac{1}{\sqrt{2}} \begin{array}{|c|} \hline 22 \\ \hline 3 \\ \hline \end{array} \rangle + \frac{1}{\sqrt{2}} \begin{array}{|c|} \hline 13 \\ \hline 3 \\ \hline \end{array} \rangle = |^2D_{M=-1}\rangle = |^2_{-1}\rangle$$

$L_- |^L_M\rangle = \sqrt{(L+M)(L-M+1)} |^L_{M-1}\rangle$ Start with top $[2,1]$ -state:

$$L_- |^2_2\rangle = \sqrt{(2+2)(2-2+1)} |^2_1\rangle = 2 |^2_1\rangle$$

$$|^2_2\rangle = \begin{array}{|c|} \hline 11 \\ \hline 2 \\ \hline \end{array} \rangle = |^2D_{M=2}\rangle$$

$$|^2_1\rangle = \frac{1}{2} L_- |^2_2\rangle = \frac{1}{2} \sqrt{2} (E_{21} + E_{32}) \begin{array}{|c|} \hline 11 \\ \hline 2 \\ \hline \end{array} \rangle = \frac{1}{\sqrt{2}} \begin{array}{|c|} \hline 11 \\ \hline 2 \\ \hline \end{array} \rangle + \frac{1}{\sqrt{2}} \begin{array}{|c|} \hline 11 \\ \hline 3 \\ \hline \end{array} \rangle = |^2D_{M=1}\rangle$$

Orthogonal $M=1$ state: $|^2P_{M=1}\rangle = |^1_1\rangle = \frac{1}{\sqrt{2}} \begin{array}{|c|} \hline 11 \\ \hline 2 \\ \hline \end{array} \rangle - \frac{1}{\sqrt{2}} \begin{array}{|c|} \hline 11 \\ \hline 3 \\ \hline \end{array} \rangle = |^2P_{M=1}\rangle$

$\begin{array}{|c|} \hline \square \square \\ \hline \square \end{array} = [2,1]$ tableau states lowered by $L_- = \sqrt{2}(E_{21} + E_{32})$

	$M=2$	$M=1$	$M=0$	$M=-1$	$M=-2$			
E_{jk}	$\begin{array}{ c } \hline 11 \\ \hline 2 \end{array}$	$\begin{array}{ c } \hline 12 \\ \hline 2 \end{array}$	$\begin{array}{ c } \hline 11 \\ \hline 3 \end{array}$	$\begin{array}{ c } \hline 12 \\ \hline 3 \end{array}$	$\begin{array}{ c } \hline 13 \\ \hline 2 \end{array}$	$\begin{array}{ c } \hline 13 \\ \hline 3 \end{array}$	$\begin{array}{ c } \hline 22 \\ \hline 3 \end{array}$	$\begin{array}{ c } \hline 23 \\ \hline 3 \end{array}$
$\langle \begin{array}{ c } \hline 11 \\ \hline 2 \end{array} $	$\begin{array}{cc} (11) & (22) \\ 2 & +1 \end{array}$	$\begin{array}{cc} (12) & (23) \\ 1 & 1 \end{array}$	$\begin{array}{cc} (13) & (13) \\ -\sqrt{\frac{1}{2}} & \sqrt{\frac{3}{2}} \end{array}$	\cdot	\cdot	\cdot	\cdot	\cdot
$\langle \begin{array}{ c } \hline 12 \\ \hline 2 \end{array} $	$\begin{array}{cc} (21) \\ 1 \end{array}$	$\begin{array}{cc} (11) & (22) \\ 1 & +2 \end{array}$	$\begin{array}{cc} (23) & (23) \\ \sqrt{\frac{1}{2}} & \sqrt{\frac{3}{2}} \end{array}$	\cdot	$\begin{array}{cc} (13) \\ -1 \end{array}$	\cdot	\cdot	\cdot
$\langle \begin{array}{ c } \hline 11 \\ \hline 3 \end{array} $	$\begin{array}{cc} (32) \\ 1 \end{array}$	\cdot	$\begin{array}{cc} (11) & (33) \\ 2 & +1 \end{array}$	$\begin{array}{cc} (12) \\ \sqrt{2} \end{array}$	\cdot	$\begin{array}{cc} (13) \\ 1 \end{array}$	\cdot	\cdot
$\langle \begin{array}{ c } \hline 12 \\ \hline 3 \end{array} $	$\begin{array}{cc} (31) \\ -\sqrt{\frac{1}{2}} \end{array}$	$\begin{array}{cc} (32) \\ \sqrt{\frac{1}{2}} \end{array}$	$\begin{array}{cc} (21) \\ \sqrt{2} \end{array}$	$\begin{array}{ccc} (11) & (22) & (33) \\ 1 & +1 & +1 \end{array}$	\cdot	$\begin{array}{cc} (23) & (12) \\ \sqrt{\frac{1}{2}} & \sqrt{2} \end{array}$	$\begin{array}{cc} (13) \\ \sqrt{\frac{1}{2}} \end{array}$	$\begin{array}{cc} (13) \\ \sqrt{\frac{1}{2}} \end{array}$
$\langle \begin{array}{ c } \hline 13 \\ \hline 2 \end{array} $	$\begin{array}{cc} (31) \\ \sqrt{\frac{3}{2}} \end{array}$	$\begin{array}{cc} (32) \\ \sqrt{\frac{3}{2}} \end{array}$	\cdot	$\begin{array}{ccc} (11) & (22) & (33) \\ 1 & +1 & +1 \end{array}$	\cdot	$\begin{array}{cc} (23) \\ \sqrt{\frac{3}{2}} \end{array}$	\cdot	$\begin{array}{cc} (13) \\ \sqrt{\frac{3}{2}} \end{array}$
$\langle \begin{array}{ c } \hline 13 \\ \hline 3 \end{array} $	\cdot	\cdot	$\begin{array}{cc} (31) \\ 1 \end{array}$	$\begin{array}{cc} (32) \\ \sqrt{\frac{1}{2}} \end{array}$	$\begin{array}{cc} (32) \\ \sqrt{\frac{3}{2}} \end{array}$	$\begin{array}{cc} (11) & (33) \\ 1 & +2 \end{array}$	\cdot	$\begin{array}{cc} (12) \\ 1 \end{array}$
$\langle \begin{array}{ c } \hline 22 \\ \hline 3 \end{array} $	\cdot	$\begin{array}{cc} (31) \\ -1 \end{array}$	\cdot	$\begin{array}{cc} (21) \\ \sqrt{2} \end{array}$	\cdot	$\begin{array}{cc} (22) & (33) \\ 2 & +1 \end{array}$	$\begin{array}{cc} (23) \\ 1 \end{array}$	$\begin{array}{cc} (23) \\ 1 \end{array}$
$\langle \begin{array}{ c } \hline 23 \\ \hline 3 \end{array} $	\cdot	\cdot	\cdot	$\begin{array}{cc} (31) \\ \sqrt{\frac{1}{2}} \end{array}$	$\begin{array}{cc} (31) \\ \sqrt{\frac{3}{2}} \end{array}$	$\begin{array}{cc} (21) & (32) \\ 1 & 1 \end{array}$	$\begin{array}{cc} (22) & (33) \\ 1 & +2 \end{array}$	$\begin{array}{cc} (22) & (33) \\ 1 & +2 \end{array}$

$L_z \equiv \begin{pmatrix} 1 & \cdot & \cdot \\ \cdot & 0 & \cdot \\ \cdot & \cdot & -1 \end{pmatrix} = (E_{11} - E_{33}) = \sqrt{2} \mathbf{v}_0$ Dipole ($k=1$)
 \angle -momentum
L-operators

E_{jk} -matrix
 Lect.23
 p.7-16
 and p.74

$L_+ \equiv \sqrt{2} \begin{pmatrix} \cdot & 1 & \cdot \\ \cdot & \cdot & 1 \\ \cdot & \cdot & \cdot \end{pmatrix} = \sqrt{2}(E_{12} + E_{23}) = L_x + iL_y = -\sqrt{2} \mathbf{v}_1$

$L_- \equiv \sqrt{2} \begin{pmatrix} \cdot & \cdot & \cdot \\ 1 & \cdot & \cdot \\ \cdot & 1 & \cdot \end{pmatrix} = \sqrt{2}(E_{21} + E_{32}) = L_x - iL_y = \sqrt{2} \mathbf{v}_{-1}$

$L_- |^2_1\rangle = \sqrt{(2+1)(2-1+1)} |^2_0\rangle = \sqrt{6} |^2_0\rangle$

$|^2_0\rangle = \frac{1}{\sqrt{6}} L_- |^2_1\rangle = \frac{1}{\sqrt{6}} \sqrt{2} (E_{21} + E_{32}) \frac{1}{\sqrt{2}} \left(\begin{array}{|c|} \hline 12 \\ \hline 2 \end{array} \rangle + \begin{array}{|c|} \hline 11 \\ \hline 3 \end{array} \rangle \right)$

$= \frac{1}{\sqrt{6}} \left(E_{21} \begin{array}{|c|} \hline 12 \\ \hline 2 \end{array} \rangle + E_{21} \begin{array}{|c|} \hline 11 \\ \hline 3 \end{array} \rangle + E_{32} \begin{array}{|c|} \hline 12 \\ \hline 2 \end{array} \rangle + E_{32} \begin{array}{|c|} \hline 11 \\ \hline 3 \end{array} \rangle \right)$

$= \frac{1}{\sqrt{6}} \left(0 \begin{array}{|c|} \hline 12 \\ \hline 2 \end{array} \rangle + \sqrt{2} \begin{array}{|c|} \hline 11 \\ \hline 3 \end{array} \rangle + \sqrt{\frac{1}{2}} \begin{array}{|c|} \hline 12 \\ \hline 3 \end{array} \rangle + \sqrt{\frac{3}{2}} \begin{array}{|c|} \hline 11 \\ \hline 2 \end{array} \rangle + 0 \begin{array}{|c|} \hline 11 \\ \hline 3 \end{array} \rangle \right)$

$= \frac{1}{\sqrt{6}} \left(\frac{3}{\sqrt{2}} \begin{array}{|c|} \hline 11 \\ \hline 3 \end{array} \rangle + \sqrt{\frac{3}{2}} \begin{array}{|c|} \hline 11 \\ \hline 2 \end{array} \rangle \right) = \frac{\sqrt{3}}{2} \begin{array}{|c|} \hline 11 \\ \hline 3 \end{array} \rangle + \frac{1}{2} \begin{array}{|c|} \hline 11 \\ \hline 2 \end{array} \rangle = |^2D_{M=0}\rangle = |^2_0\rangle$

Orthogonal ($L=1, M=0$) state: $\frac{-1}{2} \begin{array}{|c|} \hline 11 \\ \hline 3 \end{array} \rangle + \frac{\sqrt{3}}{2} \begin{array}{|c|} \hline 11 \\ \hline 2 \end{array} \rangle = |^2P_{M=0}\rangle = |^1_0\rangle$

$L_- |^2_0\rangle = \sqrt{(2+0)(2-0+1)} |^2_{-1}\rangle = \sqrt{6} |^2_{-1}\rangle$

$|^2_{-1}\rangle = \frac{1}{\sqrt{6}} L_- |^2_0\rangle = \frac{1}{\sqrt{6}} \sqrt{2} (E_{21} + E_{32}) \left(\frac{\sqrt{3}}{2} \begin{array}{|c|} \hline 11 \\ \hline 3 \end{array} \rangle + \frac{1}{2} \begin{array}{|c|} \hline 11 \\ \hline 2 \end{array} \rangle \right)$

$= \frac{1}{\sqrt{3}} \left(\frac{\sqrt{3}}{2} E_{21} \begin{array}{|c|} \hline 11 \\ \hline 3 \end{array} \rangle + \frac{1}{2} E_{21} \begin{array}{|c|} \hline 11 \\ \hline 2 \end{array} \rangle + \frac{\sqrt{3}}{2} E_{32} \begin{array}{|c|} \hline 11 \\ \hline 3 \end{array} \rangle + \frac{1}{2} E_{32} \begin{array}{|c|} \hline 11 \\ \hline 2 \end{array} \rangle \right)$

$= \frac{1}{\sqrt{3}} \left(\frac{\sqrt{3}}{2} \sqrt{\frac{1}{2}} \begin{array}{|c|} \hline 22 \\ \hline 3 \end{array} \rangle + 0 \begin{array}{|c|} \hline 22 \\ \hline 3 \end{array} \rangle + \frac{\sqrt{3}}{2} \sqrt{\frac{1}{2}} \begin{array}{|c|} \hline 13 \\ \hline 3 \end{array} \rangle + \frac{1}{2} \sqrt{\frac{3}{2}} \begin{array}{|c|} \hline 13 \\ \hline 3 \end{array} \rangle \right)$

$= \frac{1}{\sqrt{3}} \left(\sqrt{\frac{3}{2}} \begin{array}{|c|} \hline 22 \\ \hline 3 \end{array} \rangle + \sqrt{\frac{3}{2}} \begin{array}{|c|} \hline 13 \\ \hline 3 \end{array} \rangle \right) = \frac{1}{\sqrt{2}} \begin{array}{|c|} \hline 22 \\ \hline 3 \end{array} \rangle + \frac{1}{\sqrt{2}} \begin{array}{|c|} \hline 13 \\ \hline 3 \end{array} \rangle = |^2D_{M=-1}\rangle = |^2_{-1}\rangle$

Orthogonal ($L=1, M=0$) state: $\frac{-1}{\sqrt{2}} \begin{array}{|c|} \hline 22 \\ \hline 3 \end{array} \rangle + \frac{1}{\sqrt{2}} \begin{array}{|c|} \hline 13 \\ \hline 3 \end{array} \rangle = |^2P_{M=-1}\rangle = |^1_{-1}\rangle$

$L_- |^L_M\rangle = \sqrt{(L+M)(L-M+1)} |^L_{M-1}\rangle$

$L_- |^2_2\rangle = \sqrt{(2+2)(2-2+1)} |^2_1\rangle = 2 |^2_1\rangle$

$|^2_1\rangle = \frac{1}{2} L_- |^2_2\rangle = \frac{1}{2} \sqrt{2} (E_{21} + E_{32}) \begin{array}{|c|} \hline 11 \\ \hline 2 \end{array} \rangle = \frac{1}{\sqrt{2}} \begin{array}{|c|} \hline 11 \\ \hline 2 \end{array} \rangle + \frac{1}{\sqrt{2}} \begin{array}{|c|} \hline 11 \\ \hline 3 \end{array} \rangle = |^2D_{M=1}\rangle$

Orthogonal $M=1$ state: $|^2P_{M=1}\rangle = |^1_1\rangle = \frac{1}{\sqrt{2}} \begin{array}{|c|} \hline 11 \\ \hline 2 \end{array} \rangle - \frac{1}{\sqrt{2}} \begin{array}{|c|} \hline 11 \\ \hline 3 \end{array} \rangle = |^2P_{M=1}\rangle$

Start with top $[2,1]$ -state:

$|^2_2\rangle = \begin{array}{|c|} \hline 11 \\ \hline 2 \end{array} \rangle = |^2D_{M=2}\rangle$

$|^2_1\rangle = \frac{1}{2} L_- |^2_2\rangle = \frac{1}{2} \sqrt{2} (E_{21} + E_{32}) \begin{array}{|c|} \hline 11 \\ \hline 2 \end{array} \rangle = \frac{1}{\sqrt{2}} \begin{array}{|c|} \hline 11 \\ \hline 2 \end{array} \rangle + \frac{1}{\sqrt{2}} \begin{array}{|c|} \hline 11 \\ \hline 3 \end{array} \rangle = |^2D_{M=1}\rangle$

Bottom $[2,1]$ -state:

$|^2_{-2}\rangle = \begin{array}{|c|} \hline 23 \\ \hline 3 \end{array} \rangle = |^2D_{M=-2}\rangle$

Bottom $[3,0]$ -state:

$|^0_0\rangle = \begin{array}{|c|} \hline 1 \\ \hline 2 \\ \hline 3 \end{array} \rangle = |^4S_{M=0}\rangle$

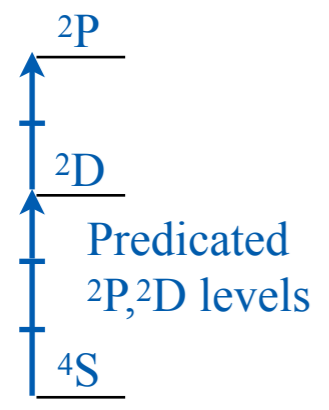

$(S_3)^*(U(3)) \subset U(6)$ models of p^3 electronic spin-orbit states and couplings

$[2,1]$ tableau states lowered by $L_- = \sqrt{2}(E_{21} + E_{32})$

Top-(J,M) states thru mid-level states

$\ell=1$ p -shell LS states combined to states of definite J



J=3/2 at L=0 (4S).

J=5/2 at L=2 (2D)

Clebsch-Gordon coupling; J=3/2 at L=2 (2D)

J=3/2 at L=1 (2P)

J=1/2 at L=1 (2P)

Spin-orbit state assembly formula and Slater determinants

The simplest assembly

$\ell=1$ p -shell LSJ states transformed to Slater determinants from J=3/2 (4S)

Slater functions for J=5/2 (2D)

Slater functions for J=3/2 (2D)

Slater functions for J=3/2 (2P)

Application to spin-orbit and entanglement break-up scattering

$\ell=1$ p -shell LS states combined to states of definite $J=3/2$ at $L=0$

$M_J=3/2, \dots$

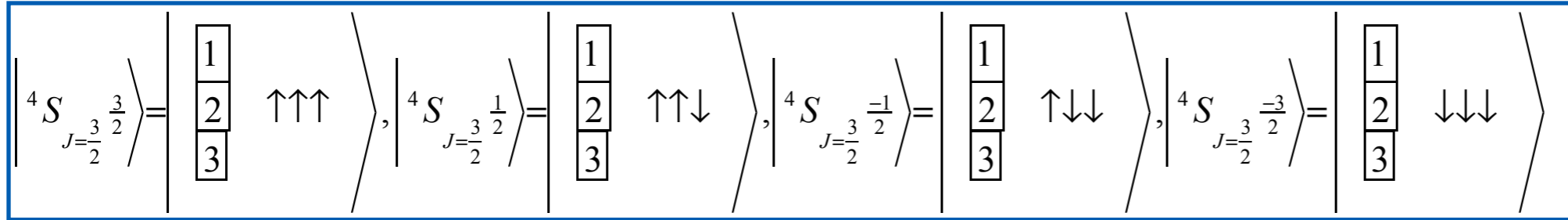

quartet 4S $J=\frac{3}{2}$,
 $M_J = \frac{+3}{2}, \frac{+1}{2}, \frac{-1}{2}, \frac{-3}{2}$.

$(S_3)^*(U(3)) \subset U(6)$ models of p^3 electronic spin-orbit states and couplings

$[2,1]$ tableau states lowered by $L_- = \sqrt{2}(E_{21} + E_{32})$

Top-(J,M) states thru mid-level states

$\ell=1$ p -shell LS states combined to states of definite J

J=3/2 at L=0 (4S).  J=5/2 at L=2 (2D)

Clebsch-Gordon coupling; J=3/2 at L=2 (2D)

J=3/2 at L=1 (2P)

J=1/2 at L=1 (2P)

Spin-orbit state assembly formula and Slater determinants

The simplest assembly

$\ell=1$ p -shell LSJ states transformed to Slater determinants from J=3/2 (4S)

Slater functions for J=5/2 (2D)

Slater functions for J=3/2 (2D)

Slater functions for J=3/2 (2P)

Application to spin-orbit and entanglement break-up scattering

$\ell=1$ p -shell LS states combined to states of definite $J=5/2$ at $L=2$

$M_J=5/2, \dots$

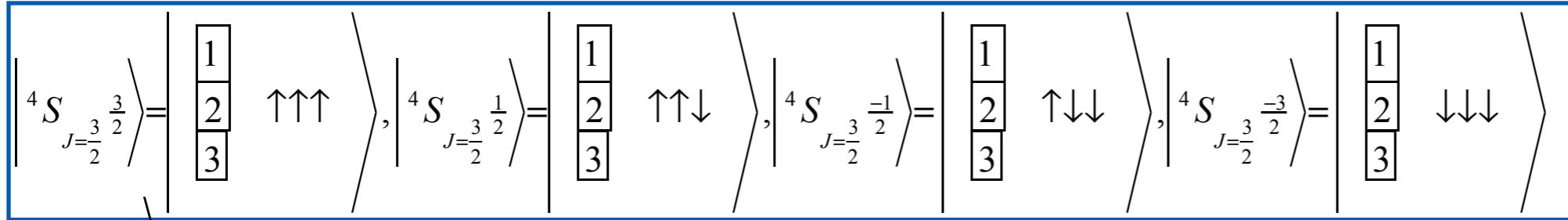

quartet 4S $J=\frac{3}{2}$,
 $M_J = \frac{+3}{2}, \frac{+1}{2}, \frac{-1}{2}, \frac{-3}{2}$.

${}^2D_{J=\frac{5}{2}}^{\frac{5}{2}} = \underline{d_{M=2}^{L=2} \chi_{1/2}^{1/2}}$ Doublet 2D , $J=\frac{5}{2}$ $M_J=\frac{5}{2}$,

$2 \times 1/2$		$5/2$				
		$+5/2$	$5/2$	$3/2$		
$+2$	$+1/2$	1	$+3/2$	$+3/2$		
$+2$	$-1/2$	$1/5$	$4/5$	$5/2$	$3/2$	
$+1$	$+1/2$	$4/5$	$-1/5$	$+1/2$	$+1/2$	
	$+1$	$2/5$	$3/5$	$5/2$	$3/2$	
	0	$3/5$	$-2/5$	$-1/2$	$-1/2$	
	0	$-1/2$	$3/5$	$2/5$	$5/2$	$3/2$
	-1	$+1/2$	$2/5$	$-3/5$	$-3/2$	$-3/2$
		-1	$-1/2$	$4/5$	$1/5$	$5/2$
		-2	$+1/2$	$1/5$	$-4/5$	$-5/2$
			-2	$-1/2$	1	

$\ell=1$ p -shell LS states combined to states of definite $J=5/2$ at $L=2$

$$\left| {}^4S_{J=\frac{3}{2}}^{\frac{3}{2}} \right\rangle = \begin{array}{|c|} \hline 1 \\ \hline 2 \\ \hline 3 \\ \hline \end{array} \uparrow\uparrow\uparrow, \quad \left| {}^4S_{J=\frac{3}{2}}^{\frac{1}{2}} \right\rangle = \begin{array}{|c|} \hline 1 \\ \hline 2 \\ \hline 3 \\ \hline \end{array} \uparrow\uparrow\downarrow, \quad \left| {}^4S_{J=\frac{3}{2}}^{\frac{-1}{2}} \right\rangle = \begin{array}{|c|} \hline 1 \\ \hline 2 \\ \hline 3 \\ \hline \end{array} \uparrow\downarrow\downarrow, \quad \left| {}^4S_{J=\frac{3}{2}}^{\frac{-3}{2}} \right\rangle = \begin{array}{|c|} \hline 1 \\ \hline 2 \\ \hline 3 \\ \hline \end{array} \downarrow\downarrow\downarrow$$

quartet 4S $J=\frac{3}{2}$, $M_J=5/2$
 $M_J = \frac{\pm 3}{2}, \frac{\pm 1}{2}, \frac{-1}{2}, \frac{-3}{2}$.

$$\left| {}^2D_{J=\frac{5}{2}}^{\frac{5}{2}} \right\rangle = \left| d_{M=2}^{L=2} \chi_{1/2}^{1/2} \right\rangle \quad \text{Doublet } {}^2D, J=\frac{5}{2} \quad M_J=\frac{5}{2},$$

$$= \begin{array}{|c|} \hline 1 \\ \hline 2 \\ \hline \end{array} \begin{array}{|c|} \hline 1 \\ \hline \end{array} \uparrow\uparrow$$

$2 \times 1/2$		$5/2$			
		$+5/2$	$5/2$	$3/2$	
$+2$	$+1/2$	1	$+3/2$	$+3/2$	
$+2$	$-1/2$	$1/5$	$4/5$	$5/2$	$3/2$
$+1$	$+1/2$	$4/5$	$-1/5$	$+1/2$	$+1/2$
$+1$	$-1/2$	$2/5$	$3/5$	$5/2$	$3/2$
0	$+1/2$	$3/5$	$-2/5$	$-1/2$	$-1/2$
0	$-1/2$	$3/5$	$2/5$	$5/2$	$3/2$
-1	$+1/2$	$2/5$	$-3/5$	$-3/2$	$-3/2$
-1	$-1/2$	$4/5$	$1/5$	$5/2$	$3/2$
-2	$+1/2$	$1/5$	$-4/5$	$-5/2$	$-5/2$
-2	$-1/2$			1	

$(S_3)^*(U(3)) \subset U(6)$ models of p^3 electronic spin-orbit states and couplings

$[2,1]$ tableau states lowered by $L_- = \sqrt{2}(E_{21} + E_{32})$

Top-(J,M) states thru mid-level states

$\ell=1$ p -shell LS states combined to states of definite J

J=3/2 at L=0 (4S). J=5/2 at L=2 (2D)

➔ Clebsch-Gordon coupling; J=3/2 at L=2 (2D)

J=3/2 at L=1 (2P)

J=1/2 at L=1 (2P)

Spin-orbit state assembly formula and Slater determinants

The simplest assembly

$\ell=1$ p -shell LSJ states transformed to Slater determinants from J=3/2 (4S)

Slater functions for J=5/2 (2D)

Slater functions for J=3/2 (2D)

Slater functions for J=3/2 (2P)

Application to spin-orbit and entanglement break-up scattering

$\ell=1$ p -shell LS states combined to states of definite $J=3/2$ at $L=2$

$$\left| {}^4S_{J=\frac{3}{2}}^{\frac{3}{2}} \right\rangle = \begin{array}{|c|} \hline 1 \\ \hline 2 \\ \hline 3 \\ \hline \end{array} \uparrow\uparrow\uparrow, \quad \left| {}^4S_{J=\frac{3}{2}}^{\frac{1}{2}} \right\rangle = \begin{array}{|c|} \hline 1 \\ \hline 2 \\ \hline 3 \\ \hline \end{array} \uparrow\uparrow\downarrow, \quad \left| {}^4S_{J=\frac{3}{2}}^{\frac{-1}{2}} \right\rangle = \begin{array}{|c|} \hline 1 \\ \hline 2 \\ \hline 3 \\ \hline \end{array} \uparrow\downarrow\downarrow, \quad \left| {}^4S_{J=\frac{3}{2}}^{\frac{-3}{2}} \right\rangle = \begin{array}{|c|} \hline 1 \\ \hline 2 \\ \hline 3 \\ \hline \end{array} \downarrow\downarrow\downarrow$$

quartet 4S $J=\frac{3}{2}$, $M_J=3/2$
 $M_J = \frac{\pm 3}{2}, \frac{\pm 1}{2}, \frac{-1}{2}, \frac{-3}{2}$.

$$\left| {}^2D_{J=\frac{5}{2}}^{\frac{5}{2}} \right\rangle = \left| d_{M=2}^{L=2} \chi_{1/2}^{1/2} \right\rangle \text{ Doublet } {}^2D, J=\frac{5}{2} M_J=\frac{5}{2}, \\
 = \begin{array}{|c|} \hline 1 \\ \hline 2 \\ \hline \end{array} \begin{array}{|c|} \hline 1 \\ \hline 1 \\ \hline \end{array} \uparrow\uparrow$$

$$\left| {}^2D_{J=\frac{5}{2}}^{\frac{3}{2}} \right\rangle = \sqrt{\frac{1}{5}} \left| d_{M=2}^{L=2} \chi_{-1/2}^{1/2} \right\rangle + \sqrt{\frac{4}{5}} \left| d_{M=1}^{L=2} \chi_{1/2}^{1/2} \right\rangle \text{ Doublet } {}^2D, J=\frac{5}{2} M_J=\frac{3}{2}$$

$2 \times 1/2$		$5/2$				
$+2$	$+1/2$	1	$5/2$	$3/2$	$5/2$	$3/2$
$+2$	$-1/2$	$1/5$	$4/5$	$5/2$	$3/2$	
$+1$	$+1/2$	$4/5$	$-1/5$	$+1/2$	$+1/2$	
$+1$	$-1/2$	$2/5$	$3/5$	$5/2$	$3/2$	
0	$+1/2$	$3/5$	$-2/5$	$-1/2$	$-1/2$	
0	$-1/2$	$3/5$	$2/5$	$5/2$	$3/2$	
-1	$+1/2$	$2/5$	$-3/5$	$-3/2$	$-3/2$	
-1	$-1/2$	$4/5$	$1/5$	$5/2$	$3/2$	
-2	$+1/2$	$1/5$	$-4/5$	$-5/2$	$-5/2$	
-2	$-1/2$	1				

$\ell=1$ p -shell LS states combined to states of definite $J=5/2$ at $L=2$

$$\left| {}^4S_{J=\frac{3}{2}}^{\frac{3}{2}} \right\rangle = \begin{array}{|c|} \hline 1 \\ \hline 2 \\ \hline 3 \\ \hline \end{array} \uparrow\uparrow\uparrow, \quad \left| {}^4S_{J=\frac{3}{2}}^{\frac{1}{2}} \right\rangle = \begin{array}{|c|} \hline 1 \\ \hline 2 \\ \hline 3 \\ \hline \end{array} \uparrow\uparrow\downarrow, \quad \left| {}^4S_{J=\frac{3}{2}}^{\frac{-1}{2}} \right\rangle = \begin{array}{|c|} \hline 1 \\ \hline 2 \\ \hline 3 \\ \hline \end{array} \uparrow\downarrow\downarrow, \quad \left| {}^4S_{J=\frac{3}{2}}^{\frac{-3}{2}} \right\rangle = \begin{array}{|c|} \hline 1 \\ \hline 2 \\ \hline 3 \\ \hline \end{array} \downarrow\downarrow\downarrow$$

quartet 4S $J=\frac{3}{2}$, $M_J=3/2$
 $M_J = \frac{\pm 3}{2}, \frac{\pm 1}{2}, \frac{-1}{2}, \frac{-3}{2}$.

$$\left| {}^2D_{J=\frac{5}{2}}^{\frac{5}{2}} \right\rangle = \left| d_{M=2}^{L=2} \chi_{1/2}^{1/2} \right\rangle \text{ Doublet } {}^2D, J=\frac{5}{2} M_J=\frac{5}{2}, \\
 = \begin{array}{|c|} \hline 1 \\ \hline 2 \\ \hline \end{array} \begin{array}{|c|} \hline 1 \\ \hline 1 \\ \hline \end{array} \uparrow\uparrow$$

$2 \times 1/2$		$5/2$		$5/2$		$3/2$	
		$+5/2$	$3/2$	$3/2$	$1/2$	$1/2$	$1/2$
$+2$	$+1/2$	1	$+3/2$	$+3/2$			
$+2$	$-1/2$	$1/5$	$4/5$	$5/2$	$3/2$		
$+1$	$+1/2$	$4/5$	$-1/5$	$+1/2$	$+1/2$		
$+1$	$-1/2$	$2/5$	$3/5$	$5/2$	$3/2$		
0	$+1/2$	$3/5$	$-2/5$	$-1/2$	$-1/2$		
0	$-1/2$	$3/5$	$2/5$	$5/2$	$3/2$		
-1	$+1/2$	$2/5$	$-3/5$	$-3/2$	$-3/2$		
-1	$-1/2$	$4/5$	$1/5$	$5/2$	$3/2$		
-2	$+1/2$	$1/5$	$-4/5$	$-5/2$	$-5/2$		
-2	$-1/2$	1					

$$\left| {}^2D_{J=\frac{5}{2}}^{\frac{3}{2}} \right\rangle = \sqrt{\frac{1}{5}} \left| d_{M=2}^{L=2} \chi_{-1/2}^{1/2} \right\rangle + \sqrt{\frac{4}{5}} \left| d_{M=1}^{L=2} \chi_{1/2}^{1/2} \right\rangle \text{ Doublet } {}^2D, J=\frac{5}{2} M_J=\frac{3}{2} \\
 = \sqrt{\frac{1}{5}} \begin{array}{|c|} \hline 1 \\ \hline 2 \\ \hline \end{array} \begin{array}{|c|} \hline 1 \\ \hline 1 \\ \hline \end{array} \uparrow\downarrow + \sqrt{\frac{4}{5}} \left[\sqrt{\frac{1}{2}} \begin{array}{|c|} \hline 1 \\ \hline 2 \\ \hline \end{array} \begin{array}{|c|} \hline \uparrow\uparrow \\ \hline \downarrow \\ \hline \end{array} + \sqrt{\frac{1}{2}} \begin{array}{|c|} \hline 1 \\ \hline 1 \\ \hline \end{array} \begin{array}{|c|} \hline \uparrow\uparrow \\ \hline \downarrow \\ \hline \end{array} \right] \\
 = \sqrt{\frac{1}{5}} \begin{array}{|c|} \hline 1 \\ \hline 2 \\ \hline \end{array} \begin{array}{|c|} \hline \uparrow\downarrow \\ \hline \downarrow \\ \hline \end{array} + \sqrt{\frac{2}{5}} \begin{array}{|c|} \hline 1 \\ \hline 2 \\ \hline \end{array} \begin{array}{|c|} \hline \uparrow\uparrow \\ \hline \downarrow \\ \hline \end{array} + \sqrt{\frac{2}{5}} \begin{array}{|c|} \hline 1 \\ \hline 1 \\ \hline \end{array} \begin{array}{|c|} \hline \uparrow\uparrow \\ \hline \downarrow \\ \hline \end{array}$$

$\ell=1$ p -shell LS states combined to states of definite $J=3/2$ at $L=2$

$$\left| {}^4S_{J=\frac{3}{2}}^{\frac{3}{2}} \right\rangle = \begin{array}{|c|} \hline 1 \\ \hline 2 \\ \hline 3 \\ \hline \end{array} \uparrow\uparrow\uparrow, \quad \left| {}^4S_{J=\frac{3}{2}}^{\frac{1}{2}} \right\rangle = \begin{array}{|c|} \hline 1 \\ \hline 2 \\ \hline 3 \\ \hline \end{array} \uparrow\uparrow\downarrow, \quad \left| {}^4S_{J=\frac{3}{2}}^{\frac{-1}{2}} \right\rangle = \begin{array}{|c|} \hline 1 \\ \hline 2 \\ \hline 3 \\ \hline \end{array} \uparrow\downarrow\downarrow, \quad \left| {}^4S_{J=\frac{3}{2}}^{\frac{-3}{2}} \right\rangle = \begin{array}{|c|} \hline 1 \\ \hline 2 \\ \hline 3 \\ \hline \end{array} \downarrow\downarrow\downarrow$$

quartet 4S $J=\frac{3}{2}$, $M_J=3/2$
 $M_J = \frac{\pm 3}{2}, \frac{\pm 1}{2}, \frac{-1}{2}, \frac{-3}{2}$.

$$\left| {}^2D_{J=\frac{5}{2}}^{\frac{5}{2}} \right\rangle = \left| d_{M=2}^{L=2} \chi_{1/2}^{1/2} \right\rangle \quad \text{Doublet } {}^2D, J=\frac{5}{2} \quad M_J=\frac{5}{2},$$

$$= \begin{array}{|c|} \hline 1 \\ \hline 2 \\ \hline \end{array} \begin{array}{|c|} \hline 1 \\ \hline 1 \\ \hline \end{array} \uparrow\uparrow$$

$2 \times 1/2$		$5/2$	$5/2$	$3/2$		
$+2$	$+1/2$	$+5/2$	1	$+3/2$	$+3/2$	
$+2$	$-1/2$	$1/5$	$4/5$	$5/2$	$3/2$	
$+1$	$+1/2$	$4/5$	$-1/5$	$+1/2$	$+1/2$	
$+1$	$-1/2$	$2/5$	$3/5$	$5/2$	$3/2$	
0	$+1/2$	$3/5$	$-2/5$	$-1/2$	$-1/2$	
0	$-1/2$	$3/5$	$2/5$	$5/2$	$3/2$	
-1	$+1/2$	$2/5$	$-3/5$	$-3/2$	$-3/2$	
-1	$-1/2$	$4/5$	$1/5$	$5/2$	$3/2$	
-2	$+1/2$	$1/5$	$-4/5$	$-5/2$	$-5/2$	
-2	$-1/2$		1			

$$\left| {}^2D_{J=\frac{5}{2}}^{\frac{3}{2}} \right\rangle = \sqrt{\frac{1}{5}} \left| d_{M=2}^{L=2} \chi_{-1/2}^{1/2} \right\rangle + \sqrt{\frac{4}{5}} \left| d_{M=1}^{L=2} \chi_{1/2}^{1/2} \right\rangle \quad \text{Doublet } {}^2D, J=\frac{5}{2} \quad M_J=\frac{3}{2}$$

$$= \sqrt{\frac{1}{5}} \begin{array}{|c|} \hline 1 \\ \hline 2 \\ \hline \end{array} \begin{array}{|c|} \hline 1 \\ \hline 1 \\ \hline \end{array} \uparrow\downarrow + \sqrt{\frac{4}{5}} \left[\sqrt{\frac{1}{2}} \begin{array}{|c|} \hline 1 \\ \hline 2 \\ \hline \end{array} \begin{array}{|c|} \hline \uparrow\uparrow \\ \hline \downarrow \\ \hline \end{array} + \sqrt{\frac{1}{2}} \begin{array}{|c|} \hline 1 \\ \hline 1 \\ \hline 3 \\ \hline \end{array} \begin{array}{|c|} \hline \uparrow\uparrow \\ \hline \downarrow \\ \hline \end{array} \right] = \sqrt{\frac{1}{5}} \begin{array}{|c|} \hline 1 \\ \hline 2 \\ \hline \end{array} \begin{array}{|c|} \hline \uparrow\downarrow \\ \hline \downarrow \\ \hline \end{array} + \sqrt{\frac{2}{5}} \begin{array}{|c|} \hline 1 \\ \hline 2 \\ \hline \end{array} \begin{array}{|c|} \hline \uparrow\uparrow \\ \hline \downarrow \\ \hline \end{array} + \sqrt{\frac{2}{5}} \begin{array}{|c|} \hline 1 \\ \hline 1 \\ \hline 3 \\ \hline \end{array} \begin{array}{|c|} \hline \uparrow\uparrow \\ \hline \downarrow \\ \hline \end{array}$$

$$\left| {}^2D_{J=\frac{3}{2}}^{\frac{3}{2}} \right\rangle = \sqrt{\frac{4}{5}} \left| d_{M=2}^{L=2} \chi_{-1/2}^{1/2} \right\rangle - \sqrt{\frac{1}{5}} \left| d_{M=1}^{L=2} \chi_{+1/2}^{1/2} \right\rangle \quad \text{Doublet } {}^2D, J=\frac{3}{2} \quad M_J=\frac{3}{2}$$

ℓ=1 p-shell LS states combined to states of definite J = 3/2 at L=2

$$\left| {}^4S_{J=\frac{3}{2}}^{\frac{3}{2}} \right\rangle = \begin{array}{|c|} \hline 1 \\ \hline 2 \\ \hline 3 \\ \hline \end{array} \uparrow\uparrow\uparrow, \quad \left| {}^4S_{J=\frac{3}{2}}^{\frac{1}{2}} \right\rangle = \begin{array}{|c|} \hline 1 \\ \hline 2 \\ \hline 3 \\ \hline \end{array} \uparrow\uparrow\downarrow, \quad \left| {}^4S_{J=\frac{3}{2}}^{\frac{-1}{2}} \right\rangle = \begin{array}{|c|} \hline 1 \\ \hline 2 \\ \hline 3 \\ \hline \end{array} \uparrow\downarrow\downarrow, \quad \left| {}^4S_{J=\frac{3}{2}}^{\frac{-3}{2}} \right\rangle = \begin{array}{|c|} \hline 1 \\ \hline 2 \\ \hline 3 \\ \hline \end{array} \downarrow\downarrow\downarrow$$

quartet 4S $J=\frac{3}{2}$, $M_J=3/2$
 $M_J = \frac{\pm 3}{2}, \frac{\pm 1}{2}, \frac{-1}{2}, \frac{-3}{2}$.

$$\left| {}^2D_{J=\frac{5}{2}}^{\frac{5}{2}} \right\rangle = \left| d_{M=2}^{L=2} \chi_{1/2}^{1/2} \right\rangle \text{ Doublet } {}^2D, J=\frac{5}{2} M_J=\frac{5}{2}, \\
 = \begin{array}{|c|} \hline 1 \\ \hline 2 \\ \hline \end{array} \begin{array}{|c|} \hline 1 \\ \hline 1 \\ \hline \end{array} \uparrow\uparrow$$

$2 \times 1/2$		$5/2$	$5/2$	$3/2$		
$+2$	$+1/2$	1	$+3/2$	$+3/2$		
$+2$	$-1/2$	$1/5$	$4/5$	$5/2$	$3/2$	
$+1$	$+1/2$	$4/5$	$-1/5$	$+1/2$	$+1/2$	
$+1$	$-1/2$	$2/5$	$3/5$	$5/2$	$3/2$	
0	$+1/2$	$3/5$	$-2/5$	$-1/2$	$-1/2$	
0	$-1/2$	$3/5$	$2/5$	$5/2$	$3/2$	
-1	$+1/2$	$2/5$	$-3/5$	$-3/2$	$-3/2$	
-1	$-1/2$	$4/5$	$1/5$	$5/2$	$3/2$	
-2	$+1/2$	$1/5$	$-4/5$	$-5/2$	$-5/2$	
-2	$-1/2$			1		

$$\left| {}^2D_{J=\frac{5}{2}}^{\frac{3}{2}} \right\rangle = \sqrt{\frac{1}{5}} \left| d_{M=2}^{L=2} \chi_{-1/2}^{1/2} \right\rangle + \sqrt{\frac{4}{5}} \left| d_{M=1}^{L=2} \chi_{1/2}^{1/2} \right\rangle \text{ Doublet } {}^2D, J=\frac{5}{2} M_J=\frac{3}{2}$$

$$= \sqrt{\frac{1}{5}} \begin{array}{|c|} \hline 1 \\ \hline 2 \\ \hline \end{array} \begin{array}{|c|} \hline 1 \\ \hline 1 \\ \hline \end{array} \uparrow\downarrow + \sqrt{\frac{4}{5}} \left[\sqrt{\frac{1}{2}} \begin{array}{|c|} \hline 1 \\ \hline 2 \\ \hline \end{array} \begin{array}{|c|} \hline 2 \\ \hline 1 \\ \hline \end{array} \uparrow\uparrow + \sqrt{\frac{1}{2}} \begin{array}{|c|} \hline 1 \\ \hline 1 \\ \hline 3 \\ \hline \end{array} \begin{array}{|c|} \hline 1 \\ \hline 1 \\ \hline \end{array} \uparrow\uparrow \right] = \sqrt{\frac{1}{5}} \begin{array}{|c|} \hline 1 \\ \hline 2 \\ \hline \end{array} \begin{array}{|c|} \hline 1 \\ \hline 1 \\ \hline \end{array} \uparrow\downarrow + \sqrt{\frac{2}{5}} \begin{array}{|c|} \hline 1 \\ \hline 2 \\ \hline \end{array} \begin{array}{|c|} \hline 1 \\ \hline 2 \\ \hline \end{array} \uparrow\uparrow + \sqrt{\frac{2}{5}} \begin{array}{|c|} \hline 1 \\ \hline 1 \\ \hline 3 \\ \hline \end{array} \begin{array}{|c|} \hline 1 \\ \hline 1 \\ \hline \end{array} \uparrow\uparrow$$

$$\left| {}^2D_{J=\frac{3}{2}}^{\frac{3}{2}} \right\rangle = \sqrt{\frac{4}{5}} \left| d_{M=2}^{L=2} \chi_{-1/2}^{1/2} \right\rangle - \sqrt{\frac{1}{5}} \left| d_{M=1}^{L=2} \chi_{+1/2}^{1/2} \right\rangle \text{ Doublet } {}^2D, J=\frac{3}{2} M_J=\frac{3}{2}$$

$$= \sqrt{\frac{4}{5}} \begin{array}{|c|} \hline 1 \\ \hline 2 \\ \hline \end{array} \begin{array}{|c|} \hline 1 \\ \hline 1 \\ \hline \end{array} \uparrow\downarrow - \sqrt{\frac{1}{5}} \left[\sqrt{\frac{1}{2}} \begin{array}{|c|} \hline 1 \\ \hline 2 \\ \hline \end{array} \begin{array}{|c|} \hline 1 \\ \hline 2 \\ \hline \end{array} \uparrow\uparrow + \sqrt{\frac{1}{2}} \begin{array}{|c|} \hline 1 \\ \hline 1 \\ \hline 3 \\ \hline \end{array} \begin{array}{|c|} \hline 1 \\ \hline 1 \\ \hline \end{array} \uparrow\uparrow \right] = \sqrt{\frac{4}{5}} \begin{array}{|c|} \hline 1 \\ \hline 2 \\ \hline \end{array} \begin{array}{|c|} \hline 1 \\ \hline 1 \\ \hline \end{array} \uparrow\downarrow - \sqrt{\frac{1}{10}} \begin{array}{|c|} \hline 1 \\ \hline 2 \\ \hline \end{array} \begin{array}{|c|} \hline 1 \\ \hline 2 \\ \hline \end{array} \uparrow\uparrow - \sqrt{\frac{1}{10}} \begin{array}{|c|} \hline 1 \\ \hline 1 \\ \hline 3 \\ \hline \end{array} \begin{array}{|c|} \hline 1 \\ \hline 1 \\ \hline \end{array} \uparrow\uparrow$$

$(S_3)^*(U(3)) \subset U(6)$ models of p^3 electronic spin-orbit states and couplings

$[2,1]$ tableau states lowered by $L_- = \sqrt{2}(E_{21} + E_{32})$

Top-(J,M) states thru mid-level states

$\ell=1$ p -shell LS states combined to states of definite J

J=3/2 at L=0 (4S). J=5/2 at L=2 (2D)

Clebsch-Gordon coupling; J=3/2 at L=2 (2D)

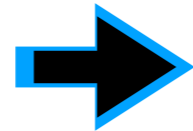

J=3/2 at L=1 (2P)

J=1/2 at L=1 (2P)

Spin-orbit state assembly formula and Slater determinants

The simplest assembly

$\ell=1$ p -shell LSJ states transformed to Slater determinants from J=3/2 (4S)

Slater functions for J=5/2 (2D)

Slater functions for J=3/2 (2D)

Slater functions for J=3/2 (2P)

Application to spin-orbit and entanglement break-up scattering

$\ell=1$ p -shell LS states combined to states of definite $J = 3/2$ at $L=1$
 Doublet 2P , $J = \frac{3}{2}$ $M_J = \frac{3}{2}$ $M_J = 3/2$

$$\left| {}^2P_{J=\frac{3}{2}}^{\frac{3}{2}} \right\rangle = \left| P_{M=1}^{L=1} \chi_{+1/2} \right\rangle$$

$1 \times 1/2$		$3/2$				
		$+3/2$	$3/2$	$1/2$		
$+1$	$+1/2$	1	$+1/2$	$+1/2$		
$+1$	$-1/2$	$1/3$	$2/3$	$3/2$	$1/2$	
0	$+1/2$	$2/3$	$-1/3$	$-1/2$	$-1/2$	
		0	$-1/2$	$2/3$	$1/3$	$3/2$
		-1	$+1/2$	$1/3$	$-2/3$	$-3/2$
				-1	$-1/2$	1

$\ell=1$ p -shell LS states combined to states of definite $J=3/2$ at $L=1$
 Doublet 2P , $J=3/2$ $M_J=3/2$
 $M_J=3/2$

$$\left| {}^2P_{J=3/2}^{3/2} \right\rangle = \left| p_{M=1}^{L=1} \chi_{+1/2}^{1/2} \right\rangle$$

$$= \left[\sqrt{\frac{1}{2}} \begin{array}{|c|c|} \hline 1 & 2 \\ \hline 2 & \\ \hline \end{array} \begin{array}{c} \uparrow\uparrow \\ \downarrow \end{array} - \sqrt{\frac{1}{2}} \begin{array}{|c|c|} \hline 1 & 1 \\ \hline 3 & \\ \hline \end{array} \begin{array}{c} \uparrow\uparrow \\ \downarrow \end{array} \right]$$

$1 \times 1/2$		$3/2$				
		$+3/2$	$3/2$	$1/2$		
$+1$	$+1/2$	1	$+1/2$	$+1/2$		
$+1$	$-1/2$	$1/3$	$2/3$	$3/2$	$1/2$	
0	$+1/2$	$2/3$	$-1/3$	$-1/2$	$-1/2$	
		0	$-1/2$	$2/3$	$1/3$	$3/2$
		-1	$+1/2$	$1/3$	$-2/3$	$-3/2$
				-1	$-1/2$	1

$\ell=1$ p -shell LS states combined to states of definite $J=3/2$ at $L=1$
 Doublet 2P , $J=3/2$ $M_J=3/2$
 $M_J=1/2$

$$\left| {}^2P_{J=3/2}^{3/2} \right\rangle = \left| p_{M=1}^{L=1} \chi_{+1/2}^{1/2} \right\rangle$$

$$= \left[\sqrt{\frac{1}{2}} \begin{array}{|c|c|} \hline 1 & 2 \\ \hline 2 & \\ \hline \end{array} \uparrow\uparrow \downarrow - \sqrt{\frac{1}{2}} \begin{array}{|c|c|} \hline 1 & 1 \\ \hline 3 & \\ \hline \end{array} \uparrow\uparrow \downarrow \right]$$

$$\left| {}^2P_{J=3/2}^{1/2} \right\rangle = \sqrt{\frac{1}{3}} \left| p_{M=1}^{L=1} \chi_{-1/2}^{1/2} \right\rangle + \sqrt{\frac{2}{3}} \left| p_{M=0}^{L=1} \chi_{+1/2}^{1/2} \right\rangle$$

Doublet 2P , $J=3/2$ $M_J=1/2$

$1 \times 1/2$		$3/2$				
		$+3/2$	$3/2$	$1/2$		
$+1$	$+1/2$	1	$+1/2$	$+1/2$		
			$+1 - 1/2$	$1/3$	$2/3$	$3/2$ $1/2$
			$0 + 1/2$	$2/3$	$-1/3$	$-1/2$ $-1/2$
					$0 - 1/2$	$2/3$ $1/3$ $3/2$
					$-1 + 1/2$	$1/3$ $-2/3$ $-3/2$
						$-1 - 1/2$ 1

$\ell=1$ p -shell LS states combined to states of definite $J=3/2$ at $L=1$
 Doublet 2P , $J=3/2$ $M_J=3/2$ $M_J=1/2$

$$\left| {}^2P_{J=3/2}^{3/2} \right\rangle = \left| p_{M=1}^{L=1} \chi_{+1/2}^{1/2} \right\rangle$$

$$= \left[\sqrt{\frac{1}{2}} \begin{array}{|c|c|} \hline 1 & 2 \\ \hline 2 & \\ \hline \end{array} \uparrow\uparrow \downarrow - \sqrt{\frac{1}{2}} \begin{array}{|c|c|} \hline 1 & 1 \\ \hline 3 & \\ \hline \end{array} \uparrow\uparrow \downarrow \right]$$

$1 \times 1/2$		$3/2$	$3/2$	$1/2$		
$+1$	$+1/2$	1	$+1/2$	$+1/2$		
$+1$	$-1/2$	$1/3$	$2/3$	$3/2$	$1/2$	
0	$+1/2$	$2/3$	$-1/3$	$-1/2$	$-1/2$	
0	$-1/2$	$2/3$	$1/3$	$3/2$	$1/2$	
-1	$+1/2$	$1/3$	$-2/3$	$-3/2$		
	-1	$-1/2$	1			

$$\left| {}^2P_{J=3/2}^{1/2} \right\rangle = \sqrt{\frac{1}{3}} \left| p_{M=1}^{L=1} \chi_{-1/2}^{1/2} \right\rangle + \sqrt{\frac{2}{3}} \left| p_{M=0}^{L=1} \chi_{+1/2}^{1/2} \right\rangle$$

$$= \sqrt{\frac{1}{3}} \left[\sqrt{\frac{1}{2}} \begin{array}{|c|c|} \hline 1 & 2 \\ \hline 2 & \\ \hline \end{array} \uparrow\downarrow \downarrow - \sqrt{\frac{1}{2}} \begin{array}{|c|c|} \hline 1 & 1 \\ \hline 3 & \\ \hline \end{array} \uparrow\downarrow \downarrow \right] + \sqrt{\frac{2}{3}} \left[\begin{array}{|c|c|} \hline -1/2 & 1 & 2 \\ \hline 3 & \\ \hline \end{array} \uparrow\uparrow \downarrow + \frac{\sqrt{3}}{2} \begin{array}{|c|c|} \hline 1 & 3 \\ \hline 2 & \\ \hline \end{array} \uparrow\uparrow \downarrow \right]$$

$\ell=1$ p -shell LS states combined to states of definite $J=3/2$ at $L=1$
 Doublet 2P , $J=3/2$ $M_J=3/2$ $M_J=1/2$

$$\left| {}^2P_{J=3/2} \frac{3}{2} \right\rangle = \left| p_{M=1}^{L=1} \chi_{+1/2}^{1/2} \right\rangle$$

$$= \left[\sqrt{\frac{1}{2}} \begin{array}{|c|c|} \hline 1 & 2 \\ \hline 2 & \\ \hline \end{array} \uparrow\uparrow \downarrow - \sqrt{\frac{1}{2}} \begin{array}{|c|c|} \hline 1 & 1 \\ \hline 3 & \\ \hline \end{array} \uparrow\uparrow \downarrow \right]$$

$1 \times 1/2$		$3/2$						
$+1$	$+1/2$	1	$3/2$	$1/2$				
$+1$	$-1/2$	$1/3$	$2/3$	$3/2$	$1/2$			
0	$+1/2$	$2/3$	$-1/3$	$-1/2$	$-1/2$			
0	$-1/2$	$2/3$	$1/3$	$3/2$				
-1	$+1/2$	$1/3$	$-2/3$	$-3/2$				
-1		$-1/2$	1					

$$\left| {}^2P_{J=3/2} \frac{1}{2} \right\rangle = \sqrt{\frac{1}{3}} \left| p_{M=1}^{L=1} \chi_{-1/2}^{1/2} \right\rangle + \sqrt{\frac{2}{3}} \left| p_{M=0}^{L=1} \chi_{+1/2}^{1/2} \right\rangle$$

$$= \sqrt{\frac{1}{3}} \left[\sqrt{\frac{1}{2}} \begin{array}{|c|c|} \hline 1 & 2 \\ \hline 2 & \\ \hline \end{array} \uparrow\downarrow \downarrow - \sqrt{\frac{1}{2}} \begin{array}{|c|c|} \hline 1 & 1 \\ \hline 3 & \\ \hline \end{array} \uparrow\downarrow \downarrow \right] + \sqrt{\frac{2}{3}} \left[\begin{array}{|c|c|} \hline 1 & 2 \\ \hline 3 & \\ \hline \end{array} \uparrow\uparrow \downarrow + \frac{\sqrt{3}}{2} \begin{array}{|c|c|} \hline 1 & 3 \\ \hline 2 & \\ \hline \end{array} \uparrow\uparrow \downarrow \right]$$

$$= \sqrt{\frac{1}{6}} \begin{array}{|c|c|} \hline 1 & 2 \\ \hline 2 & \\ \hline \end{array} \uparrow\downarrow \downarrow - \sqrt{\frac{1}{6}} \begin{array}{|c|c|} \hline 1 & 1 \\ \hline 3 & \\ \hline \end{array} \uparrow\downarrow \downarrow - \sqrt{\frac{1}{6}} \begin{array}{|c|c|} \hline 1 & 2 \\ \hline 3 & \\ \hline \end{array} \uparrow\uparrow \downarrow + \frac{1}{\sqrt{2}} \begin{array}{|c|c|} \hline 1 & 3 \\ \hline 2 & \\ \hline \end{array} \uparrow\uparrow \downarrow$$

$(S_3)^*(U(3)) \subset U(6)$ models of p^3 electronic spin-orbit states and couplings

$[2,1]$ tableau states lowered by $L_- = \sqrt{2}(E_{21} + E_{32})$

Top-(J,M) states thru mid-level states

$\ell=1$ p -shell LS states combined to states of definite J

J=3/2 at L=0 (4S). J=5/2 at L=2 (2D)

Clebsch-Gordon coupling; J=3/2 at L=2 (2D)

J=3/2 at L=1 (2P)

J=1/2 at L=1 (2P)

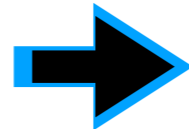

Spin-orbit state assembly formula and Slater determinants

The simplest assembly

$\ell=1$ p -shell LSJ states transformed to Slater determinants from J=3/2 (4S)

Slater functions for J=5/2 (2D)

Slater functions for J=3/2 (2D)

Slater functions for J=3/2 (2P)

Application to spin-orbit and entanglement break-up scattering

$\ell=1$ p -shell LS states combined to states of definite $J=1/2$ at $L=1$
 Doublet 2P , $J=\frac{3}{2}$ $M_J=\frac{3}{2}$ $M_J=1/2$

$$\left| {}^2P_{J=\frac{3}{2}} \frac{3}{2} \right\rangle = \left| p_{M=1}^{L=1} \chi_{+1/2}^{1/2} \right\rangle$$

$$= \left[\left[\sqrt{\frac{1}{2}} \begin{array}{|c|c|} \hline 1 & 2 \\ \hline 2 & \\ \hline \end{array} \uparrow\uparrow \downarrow - \sqrt{\frac{1}{2}} \begin{array}{|c|c|} \hline 1 & 1 \\ \hline 3 & \\ \hline \end{array} \uparrow\uparrow \downarrow \right] \right]$$

$$\left| {}^2P_{J=\frac{3}{2}} \frac{1}{2} \right\rangle = \sqrt{\frac{1}{3}} \left| p_{M=1}^{L=1} \chi_{-1/2}^{1/2} \right\rangle + \sqrt{\frac{2}{3}} \left| p_{M=0}^{L=1} \chi_{+1/2}^{1/2} \right\rangle$$

$$= \sqrt{\frac{1}{3}} \left[\left[\sqrt{\frac{1}{2}} \begin{array}{|c|c|} \hline 1 & 2 \\ \hline 2 & \\ \hline \end{array} \uparrow\downarrow \downarrow - \sqrt{\frac{1}{2}} \begin{array}{|c|c|} \hline 1 & 1 \\ \hline 3 & \\ \hline \end{array} \uparrow\downarrow \downarrow \right] + \sqrt{\frac{2}{3}} \left[\begin{array}{|c|c|} \hline -\frac{1}{2} & 1 & 2 \\ \hline 3 & \\ \hline \end{array} \uparrow\uparrow \downarrow + \frac{\sqrt{3}}{2} \begin{array}{|c|c|} \hline 1 & 3 \\ \hline 2 & \\ \hline \end{array} \uparrow\uparrow \downarrow \right] \right]$$

$$= \sqrt{\frac{1}{6}} \begin{array}{|c|c|} \hline 1 & 2 \\ \hline 2 & \\ \hline \end{array} \uparrow\downarrow \downarrow - \sqrt{\frac{1}{6}} \begin{array}{|c|c|} \hline 1 & 1 \\ \hline 3 & \\ \hline \end{array} \uparrow\downarrow \downarrow - \sqrt{\frac{1}{6}} \begin{array}{|c|c|} \hline 1 & 2 \\ \hline 3 & \\ \hline \end{array} \uparrow\uparrow \downarrow + \frac{1}{\sqrt{2}} \begin{array}{|c|c|} \hline 1 & 3 \\ \hline 2 & \\ \hline \end{array} \uparrow\uparrow \downarrow$$

$1 \times 1/2$		$3/2$	$3/2$	$1/2$		
$+1$	$+1/2$	$+3/2$	1	$+1/2$	$+1/2$	
$+1$	$-1/2$	$1/3$	$2/3$	$3/2$	$1/2$	
0	$+1/2$	$2/3$	$-1/3$	$-1/2$	$-1/2$	
0	$-1/2$	$2/3$	$1/3$	$3/2$	$1/2$	
-1	$+1/2$	$1/3$	$-2/3$	$-3/2$		
-1	$-1/2$			1		

$$\left| {}^2P_{J=\frac{1}{2}} \frac{1}{2} \right\rangle = \sqrt{\frac{2}{3}} \left| p_{M=1}^{L=1} \chi_{-1/2}^{1/2} \right\rangle - \sqrt{\frac{1}{3}} \left| p_{M=0}^{L=1} \chi_{+1/2}^{1/2} \right\rangle$$

Doublet 2P , $J=\frac{1}{2}$ $M_J=\frac{1}{2}$

$\ell=1$ p -shell LS states combined to states of definite $J=1/2$ at $L=1$
 Doublet 2P , $J=\frac{3}{2}$ $M_J=\frac{3}{2}$ $M_J=1/2$

$$\left| {}^2P_{J=\frac{3}{2}} \frac{3}{2} \right\rangle = \left| p_{M=1}^{L=1} \chi_{+1/2}^{1/2} \right\rangle$$

$$= \left[\left[\sqrt{\frac{1}{2}} \begin{array}{|c|c|} \hline 1 & 2 \\ \hline 2 & \\ \hline \end{array} \uparrow\uparrow \downarrow - \sqrt{\frac{1}{2}} \begin{array}{|c|c|} \hline 1 & 1 \\ \hline 3 & \\ \hline \end{array} \uparrow\uparrow \downarrow \right] \right]$$

$1 \times 1/2$	$3/2$	$3/2$	$1/2$		
$+1 +1/2$	$+3/2$	$1 +1/2$	$+1/2$		
$+1 -1/2$	$1/3$	$2/3$	$3/2$	$1/2$	
$0 +1/2$	$2/3$	$-1/3$	$-1/2$	$-1/2$	
	$0 -1/2$	$2/3$	$1/3$	$3/2$	
	$-1 +1/2$	$1/3$	$-2/3$	$-3/2$	
		$-1 -1/2$	1		

$$\left| {}^2P_{J=\frac{3}{2}} \frac{1}{2} \right\rangle = \sqrt{\frac{1}{3}} \left| p_{M=1}^{L=1} \chi_{-1/2}^{1/2} \right\rangle + \sqrt{\frac{2}{3}} \left| p_{M=0}^{L=1} \chi_{+1/2}^{1/2} \right\rangle$$

$$= \sqrt{\frac{1}{3}} \left[\left[\sqrt{\frac{1}{2}} \begin{array}{|c|c|} \hline 1 & 2 \\ \hline 2 & \\ \hline \end{array} \uparrow\downarrow \downarrow - \sqrt{\frac{1}{2}} \begin{array}{|c|c|} \hline 1 & 1 \\ \hline 3 & \\ \hline \end{array} \uparrow\downarrow \downarrow \right] \right] + \sqrt{\frac{2}{3}} \left[\left[-\frac{1}{2} \begin{array}{|c|c|} \hline 1 & 2 \\ \hline 3 & \\ \hline \end{array} \uparrow\uparrow \downarrow + \frac{\sqrt{3}}{2} \begin{array}{|c|c|} \hline 1 & 3 \\ \hline 2 & \\ \hline \end{array} \uparrow\uparrow \downarrow \right] \right]$$

$$= \sqrt{\frac{1}{6}} \begin{array}{|c|c|} \hline 1 & 2 \\ \hline 2 & \\ \hline \end{array} \uparrow\downarrow \downarrow - \sqrt{\frac{1}{6}} \begin{array}{|c|c|} \hline 1 & 1 \\ \hline 3 & \\ \hline \end{array} \uparrow\downarrow \downarrow - \sqrt{\frac{1}{6}} \begin{array}{|c|c|} \hline 1 & 2 \\ \hline 3 & \\ \hline \end{array} \uparrow\uparrow \downarrow + \frac{1}{\sqrt{2}} \begin{array}{|c|c|} \hline 1 & 3 \\ \hline 2 & \\ \hline \end{array} \uparrow\uparrow \downarrow$$

$$\left| {}^2P_{J=\frac{1}{2}} \frac{1}{2} \right\rangle = \sqrt{\frac{2}{3}} \left| p_{M=1}^{L=1} \chi_{-1/2}^{1/2} \right\rangle - \sqrt{\frac{1}{3}} \left| p_{M=0}^{L=1} \chi_{+1/2}^{1/2} \right\rangle$$

$$= \sqrt{\frac{2}{3}} \left[\left[\sqrt{\frac{1}{2}} \begin{array}{|c|c|} \hline 1 & 2 \\ \hline 2 & \\ \hline \end{array} \uparrow\downarrow \downarrow - \sqrt{\frac{1}{2}} \begin{array}{|c|c|} \hline 1 & 1 \\ \hline 3 & \\ \hline \end{array} \uparrow\downarrow \downarrow \right] \right] - \sqrt{\frac{1}{3}} \left[\left[-\frac{1}{2} \begin{array}{|c|c|} \hline 1 & 2 \\ \hline 3 & \\ \hline \end{array} \uparrow\uparrow \downarrow + \frac{\sqrt{3}}{2} \begin{array}{|c|c|} \hline 1 & 3 \\ \hline 2 & \\ \hline \end{array} \uparrow\uparrow \downarrow \right] \right]$$

$\ell=1$ p -shell LS states combined to states of definite $J=1/2$ at $L=1$
 Doublet 2P , $J=\frac{3}{2}$ $M_J=\frac{3}{2}$ $M_J=1/2$

$$\left| {}^2P_{J=\frac{3}{2}}^{\frac{3}{2}} \right\rangle = \left| p_{M=1}^{L=1} \chi_{+1/2}^{1/2} \right\rangle$$

$$= \left[\left[\sqrt{\frac{1}{2}} \begin{array}{|c|c|} \hline 1 & 2 \\ \hline 2 & \\ \hline \end{array} \uparrow\uparrow \downarrow - \sqrt{\frac{1}{2}} \begin{array}{|c|c|} \hline 1 & 1 \\ \hline 3 & \\ \hline \end{array} \uparrow\uparrow \downarrow \right] \right]$$

$1 \times 1/2$		$3/2$	$3/2$	$1/2$		
$+1$	$+1/2$	1	$+1/2$	$+1/2$		
$+1$	$-1/2$	$1/3$	$2/3$	$3/2$	$1/2$	
0	$+1/2$	$2/3$	$-1/3$	$-1/2$	$-1/2$	
	0	$-1/2$	$2/3$	$1/3$	$3/2$	
	-1	$+1/2$	$1/3$	$-2/3$	$-3/2$	
		-1	$-1/2$		1	

$$\left| {}^2P_{J=\frac{3}{2}}^{\frac{1}{2}} \right\rangle = \sqrt{\frac{1}{3}} \left| p_{M=1}^{L=1} \chi_{-1/2}^{1/2} \right\rangle + \sqrt{\frac{2}{3}} \left| p_{M=0}^{L=1} \chi_{+1/2}^{1/2} \right\rangle$$

$$= \sqrt{\frac{1}{3}} \left[\left[\sqrt{\frac{1}{2}} \begin{array}{|c|c|} \hline 1 & 2 \\ \hline 2 & \\ \hline \end{array} \uparrow\downarrow \downarrow - \sqrt{\frac{1}{2}} \begin{array}{|c|c|} \hline 1 & 1 \\ \hline 3 & \\ \hline \end{array} \uparrow\downarrow \downarrow \right] + \sqrt{\frac{2}{3}} \left[\begin{array}{|c|c|} \hline -\frac{1}{2} & 2 \\ \hline 3 & \\ \hline \end{array} \uparrow\uparrow \downarrow + \frac{\sqrt{3}}{2} \begin{array}{|c|c|} \hline 1 & 3 \\ \hline 2 & \\ \hline \end{array} \uparrow\uparrow \downarrow \right] \right]$$

$$= \sqrt{\frac{1}{6}} \begin{array}{|c|c|} \hline 1 & 2 \\ \hline 2 & \\ \hline \end{array} \uparrow\downarrow \downarrow - \sqrt{\frac{1}{6}} \begin{array}{|c|c|} \hline 1 & 1 \\ \hline 3 & \\ \hline \end{array} \uparrow\downarrow \downarrow - \sqrt{\frac{1}{6}} \begin{array}{|c|c|} \hline 1 & 2 \\ \hline 3 & \\ \hline \end{array} \uparrow\uparrow \downarrow + \frac{1}{\sqrt{2}} \begin{array}{|c|c|} \hline 1 & 3 \\ \hline 2 & \\ \hline \end{array} \uparrow\uparrow \downarrow$$

$$\left| {}^2P_{J=\frac{1}{2}}^{\frac{1}{2}} \right\rangle = \sqrt{\frac{2}{3}} \left| p_{M=1}^{L=1} \chi_{-1/2}^{1/2} \right\rangle - \sqrt{\frac{1}{3}} \left| p_{M=0}^{L=1} \chi_{+1/2}^{1/2} \right\rangle$$

$$= \sqrt{\frac{2}{3}} \left[\left[\sqrt{\frac{1}{2}} \begin{array}{|c|c|} \hline 1 & 2 \\ \hline 2 & \\ \hline \end{array} \uparrow\downarrow \downarrow - \sqrt{\frac{1}{2}} \begin{array}{|c|c|} \hline 1 & 1 \\ \hline 3 & \\ \hline \end{array} \uparrow\downarrow \downarrow \right] - \sqrt{\frac{1}{3}} \left[\begin{array}{|c|c|} \hline -\frac{1}{2} & 2 \\ \hline 3 & \\ \hline \end{array} \uparrow\uparrow \downarrow + \frac{\sqrt{3}}{2} \begin{array}{|c|c|} \hline 1 & 3 \\ \hline 2 & \\ \hline \end{array} \uparrow\uparrow \downarrow \right] \right]$$

$$= \sqrt{\frac{1}{3}} \begin{array}{|c|c|} \hline 1 & 2 \\ \hline 2 & \\ \hline \end{array} \uparrow\downarrow \downarrow - \sqrt{\frac{1}{3}} \begin{array}{|c|c|} \hline 1 & 1 \\ \hline 3 & \\ \hline \end{array} \uparrow\downarrow \downarrow + \sqrt{\frac{1}{12}} \begin{array}{|c|c|} \hline 1 & 2 \\ \hline 3 & \\ \hline \end{array} \uparrow\uparrow \downarrow - \frac{1}{2} \begin{array}{|c|c|} \hline 1 & 3 \\ \hline 2 & \\ \hline \end{array} \uparrow\uparrow \downarrow$$

$(S_3)^*(U(3)) \subset U(6)$ models of p^3 electronic spin-orbit states and couplings

$[2,1]$ tableau states lowered by $L_- = \sqrt{2}(E_{21} + E_{32})$

Top-(J,M) states thru mid-level states

$\ell=1$ p -shell LS states combined to states of definite J

J=3/2 at L=0 (4S). J=5/2 at L=2 (2D)

Clebsch-Gordon coupling; J=3/2 at L=2 (2D)

J=3/2 at L=1 (2P)

J=1/2 at L=1 (2P)

 Spin-orbit state assembly formula and Slater determinants

The simplest assembly

$\ell=1$ p -shell LSJ states transformed to Slater determinants from J=3/2 (4S)

Slater functions for J=5/2 (2D)

Slater functions for J=3/2 (2D)

Slater functions for J=3/2 (2P)

Application to spin-orbit and entanglement break-up scattering

Introducing atomic spin-orbit state assembly formula and Slater determinants

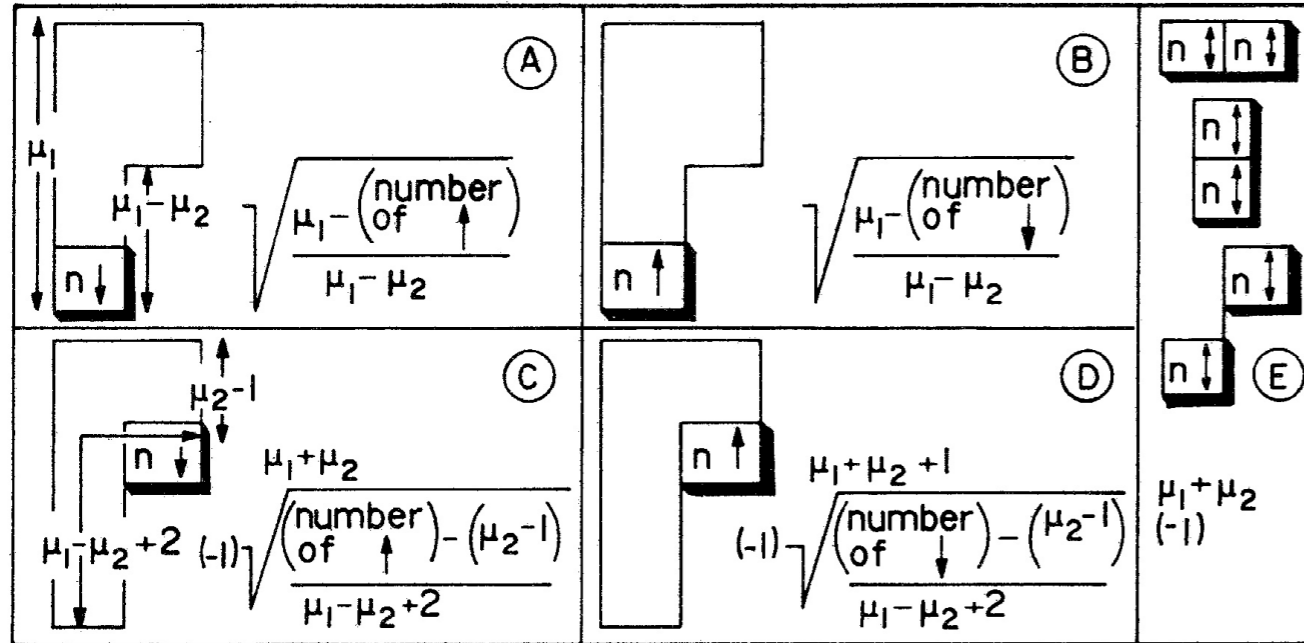

FIG. 5. Assembly formula for combining orbital and spin states. Each column state (Slater determinant) on the left-hand side of the sample table has a definite spin (arrow) on each orbital state (number). The formulas will give the overlap of this Slater state with a given orbital tableau state if we first write the spins within this orbital tableau in exactly the same way. Then we proceed to remove boxes with numbered spins starting with the highest number(s). Each "removal" gives a factor depending on what is being removed and where (cases A-E). All of the numbers in the formulas refer to the condition of the tableau just before the box outlined in the figure is removed.

EXAMPLE :

$$\left| \begin{array}{c|c|c} 1 & 2 & \uparrow \uparrow \\ \hline 3 & & \downarrow \end{array} \right\rangle \left| \begin{array}{c|c|c} 1 & 3 & \uparrow \uparrow \\ \hline 2 & & \downarrow \end{array} \right\rangle \left| \begin{array}{c|c} 1 & \\ \hline 2 & \uparrow \uparrow \downarrow \\ \hline 3 & \end{array} \right\rangle$$

Slater
determinants

$\begin{array}{c} 1 \uparrow \\ 2 \uparrow \\ 3 \downarrow \end{array}$	0	$-\sqrt{\frac{2}{3}}$	$\sqrt{\frac{1}{3}}$
$\begin{array}{c} 1 \uparrow \\ 2 \downarrow \\ 3 \uparrow \end{array}$	$\sqrt{\frac{1}{2}}$	$\sqrt{\frac{1}{6}}$	$\sqrt{\frac{1}{3}}$
$\begin{array}{c} 1 \downarrow \\ 2 \uparrow \\ 3 \uparrow \end{array}$	$-\sqrt{\frac{1}{2}}$	$\sqrt{\frac{1}{6}}$	$\sqrt{\frac{1}{3}}$

$$-\sqrt{\frac{1}{2}} = \sqrt{\frac{1}{1}} \cdot -\sqrt{\frac{1}{2}} \cdot 1$$

$\begin{array}{c} 1 \downarrow 2 \uparrow \\ \hline 3 \uparrow \end{array} \textcircled{B} \quad \begin{array}{c} 1 \downarrow 2 \uparrow \\ \hline 3 \uparrow \end{array} \textcircled{D} \quad \begin{array}{c} 1 \downarrow \\ \hline 3 \uparrow \end{array}$

Introducing atomic spin-orbit state assembly formula and Slater determinants

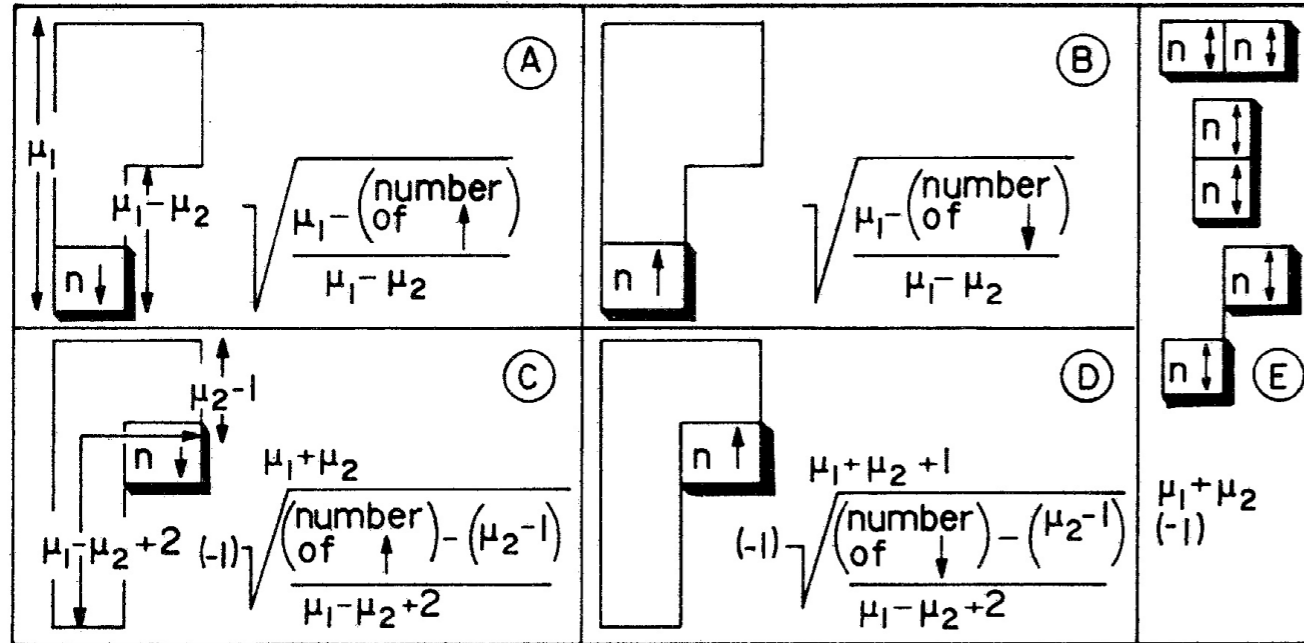

FIG. 5. Assembly formula for combining orbital and spin states. Each column state (Slater determinant) on the left-hand side of the sample table has a definite spin (arrow) on each orbital state (number). The formulas will give the overlap of this Slater state with a given orbital tableau state if we first write the spins within this orbital tableau in exactly the same way. Then we proceed to remove boxes with numbered spins starting with the highest number(s). Each “removal” gives a factor depending on what is being removed and where (cases A–E). All of the numbers in the formulas refer to the condition of the tableau just before the box outlined in the figure is removed.

The simplest assembly:

EXAMPLE :

$$\left| \begin{array}{|c|c|c|c|} \hline 1 & 2 & \uparrow & \uparrow \\ \hline 3 & & \downarrow & \\ \hline \end{array} \right\rangle \left| \begin{array}{|c|c|c|c|} \hline 1 & 3 & \uparrow & \uparrow \\ \hline 2 & & \downarrow & \\ \hline \end{array} \right\rangle \left| \begin{array}{|c|c|c|c|} \hline 1 & & & \\ \hline 2 & \uparrow & \uparrow & \downarrow \\ \hline 3 & & & \\ \hline \end{array} \right\rangle$$

Slater
determinants

$\begin{array}{ c } \hline 1 \uparrow \\ \hline 2 \uparrow \\ \hline 3 \downarrow \\ \hline \end{array}$	0	$-\sqrt{\frac{2}{3}}$	$\sqrt{\frac{1}{3}}$
$\begin{array}{ c } \hline 1 \uparrow \\ \hline 2 \downarrow \\ \hline 3 \uparrow \\ \hline \end{array}$	$\sqrt{\frac{1}{2}}$	$\sqrt{\frac{1}{6}}$	$\sqrt{\frac{1}{3}}$
$\begin{array}{ c } \hline 1 \downarrow \\ \hline 2 \uparrow \\ \hline 3 \uparrow \\ \hline \end{array}$	$-\sqrt{\frac{1}{2}}$	$\sqrt{\frac{1}{6}}$	$\sqrt{\frac{1}{3}}$

Slater
determinants

	$\begin{array}{ c c } \hline 1 & 2 \\ \hline \end{array}$	$\begin{array}{ c } \hline \uparrow \\ \hline \downarrow \\ \hline \end{array}$	$\begin{array}{ c c c } \hline 1 & \uparrow & \downarrow \\ \hline 2 & & \\ \hline \end{array}$
$\begin{array}{ c } \hline 1 \uparrow \\ \hline 2 \downarrow \\ \hline \end{array}$	$\sqrt{\frac{1}{2}}$	$\sqrt{\frac{1}{2}}$	
$\begin{array}{ c } \hline 1 \uparrow \\ \hline 2 \downarrow \\ \hline \end{array}$	$-\sqrt{\frac{1}{2}}$	$\sqrt{\frac{1}{2}}$	

$$-\sqrt{\frac{1}{2}} = \sqrt{\frac{1}{1}} \cdot -\sqrt{\frac{1}{2}} \cdot 1$$

$(S_3)^*(U(3)) \subset U(6)$ models of p^3 electronic spin-orbit states and couplings

$[2,1]$ tableau states lowered by $L_- = \sqrt{2}(E_{21} + E_{32})$

Top-(J,M) states thru mid-level states

$\ell=1$ p -shell LS states combined to states of definite J

J=3/2 at L=0 (4S). J=5/2 at L=2 (2D)

Clebsch-Gordon coupling; J=3/2 at L=2 (2D)

J=3/2 at L=1 (2P)

J=1/2 at L=1 (2P)

Spin-orbit state assembly formula and Slater determinants

 The simplest assembly (Detailed)

$\ell=1$ p -shell LSJ states transformed to Slater determinants from J=3/2 (4S)

Slater functions for J=5/2 (2D)

Slater functions for J=3/2 (2D)

Slater functions for J=3/2 (2P)

Application to spin-orbit and entanglement break-up scattering

Introducing atomic spin-orbit state assembly formula and Slater determinants

Slater determinant state key:

$$a=1\uparrow, b=1\downarrow, c=2\uparrow, d=2\downarrow$$

$$\begin{array}{|c|c|} \hline 1 & 2 \\ \hline \end{array} \quad \begin{array}{|c|} \hline \uparrow \\ \hline \downarrow \\ \hline \end{array} \\ \left(\frac{|1,2\rangle + |2,1\rangle}{\sqrt{2}} \right) \left(\frac{|\uparrow,\downarrow\rangle - |\downarrow,\uparrow\rangle}{\sqrt{2}} \right)$$

$$\begin{array}{|c|} \hline 1 \\ \hline 2 \\ \hline \end{array} \quad \begin{array}{|c|c|} \hline \uparrow & \downarrow \\ \hline \end{array} \\ \left(\frac{|1,2\rangle - |2,1\rangle}{\sqrt{2}} \right) \left(\frac{|\uparrow,\downarrow\rangle + |\downarrow,\uparrow\rangle}{\sqrt{2}} \right)$$

The simplest assembly:

	$\begin{array}{ c c } \hline 1 & 2 \\ \hline \end{array}$	$\begin{array}{ c } \hline \uparrow \\ \hline \downarrow \\ \hline \end{array}$	$\begin{array}{ c c c } \hline 1 & \uparrow & \downarrow \\ \hline 2 & & \\ \hline \end{array}$
$\begin{array}{ c } \hline 1\uparrow \\ \hline 2\downarrow \\ \hline \end{array}$		$\sqrt{\frac{1}{2}}$	$\sqrt{\frac{1}{2}}$
$\begin{array}{ c } \hline 1\downarrow \\ \hline 2\uparrow \\ \hline \end{array}$		$-\sqrt{\frac{1}{2}}$	$\sqrt{\frac{1}{2}}$

	$\begin{array}{ c c } \hline 1 & 2 \\ \hline \end{array}$	$\begin{array}{ c } \hline \uparrow \\ \hline \downarrow \\ \hline \end{array}$
$\begin{array}{ c } \hline 1\uparrow \\ \hline 2\downarrow \\ \hline \end{array}$	$a = \frac{ad - da}{\sqrt{2}}$	
$\begin{array}{ c } \hline 1\downarrow \\ \hline 2\uparrow \\ \hline \end{array}$	$b = \frac{bc - cb}{\sqrt{2}}$	

Introducing atomic spin-orbit state assembly formula and Slater determinants

Slater determinant state key:

$$a=1\uparrow, b=1\downarrow, c=2\uparrow, d=2\downarrow$$

$$\frac{1}{2} \left(\frac{|1,2\rangle + |2,1\rangle}{\sqrt{2}} \right) \left(\frac{|\uparrow,\downarrow\rangle - |\downarrow,\uparrow\rangle}{\sqrt{2}} \right)$$

$$\frac{1}{2} (|1\uparrow,2\downarrow\rangle - |2\downarrow,1\uparrow\rangle + |2\uparrow,1\downarrow\rangle - |1\downarrow,2\uparrow\rangle)$$

$$\left(\frac{|1,2\rangle - |2,1\rangle}{\sqrt{2}} \right) \left(\frac{|\uparrow,\downarrow\rangle + |\downarrow,\uparrow\rangle}{\sqrt{2}} \right)$$

The simplest assembly:

	$\begin{array}{ c c } \hline 1 & 2 \\ \hline \end{array}$	$\begin{array}{ c } \hline \uparrow \\ \hline \downarrow \\ \hline \end{array}$	$\begin{array}{ c c } \hline 1 & \uparrow \\ \hline 2 & \downarrow \\ \hline \end{array}$
$\begin{array}{ c } \hline 1\uparrow \\ \hline 2\downarrow \\ \hline \end{array}$	$\sqrt{\frac{1}{2}}$		$\sqrt{\frac{1}{2}}$
$\begin{array}{ c } \hline 1\downarrow \\ \hline 2\uparrow \\ \hline \end{array}$	$-\sqrt{\frac{1}{2}}$		$\sqrt{\frac{1}{2}}$

	$\begin{array}{ c c } \hline 1 & 2 \\ \hline \end{array}$	$\begin{array}{ c } \hline \uparrow \\ \hline \downarrow \\ \hline \end{array}$
$\begin{array}{ c } \hline 1\uparrow \\ \hline 2\downarrow \\ \hline \end{array}$	$a = \frac{ad - da}{\sqrt{2}}$	
$\begin{array}{ c } \hline 1\downarrow \\ \hline 2\uparrow \\ \hline \end{array}$	$b = \frac{bc - cb}{\sqrt{2}}$	

Introducing atomic spin-orbit state assembly formula and Slater determinants

Slater determinant state key:

$$a=1\uparrow, b=1\downarrow, c=2\uparrow, d=2\downarrow$$

The simplest assembly:

$$\frac{1}{2} \left(\frac{|1,2\rangle + |2,1\rangle}{\sqrt{2}} \right) \left(\frac{|\uparrow,\downarrow\rangle - |\downarrow,\uparrow\rangle}{\sqrt{2}} \right)$$

$$\frac{1}{2} (|1\uparrow, 2\downarrow\rangle - |2\downarrow, 1\uparrow\rangle + |2\uparrow, 1\downarrow\rangle - |1\downarrow, 2\uparrow\rangle)$$

$$\frac{1}{2} (ad - da + cb - bc)$$

$$\left(\frac{|1,2\rangle - |2,1\rangle}{\sqrt{2}} \right) \left(\frac{|\uparrow,\downarrow\rangle + |\downarrow,\uparrow\rangle}{\sqrt{2}} \right)$$

	$\begin{array}{ c c } \hline 1 & 2 \\ \hline \end{array}$	$\begin{array}{ c } \hline \uparrow \\ \hline \downarrow \\ \hline \end{array}$	$\begin{array}{ c c } \hline 1 & \uparrow \\ \hline 2 & \downarrow \\ \hline \end{array}$
$\begin{array}{ c } \hline 1\uparrow \\ \hline 2\downarrow \\ \hline \end{array}$	$\sqrt{\frac{1}{2}}$		$\sqrt{\frac{1}{2}}$
$\begin{array}{ c } \hline 1\downarrow \\ \hline 2\uparrow \\ \hline \end{array}$	$-\sqrt{\frac{1}{2}}$		$\sqrt{\frac{1}{2}}$

	$\begin{array}{ c c } \hline 1 & 2 \\ \hline \end{array}$	$\begin{array}{ c } \hline \uparrow \\ \hline \downarrow \\ \hline \end{array}$	$\frac{1}{2}(ad - da + cb - bc)$
$\begin{array}{ c } \hline 1\uparrow \\ \hline 2\downarrow \\ \hline \end{array}$	a	$d = \frac{ad - da}{\sqrt{2}}$	
$\begin{array}{ c } \hline 1\downarrow \\ \hline 2\uparrow \\ \hline \end{array}$	b	$c = \frac{bc - cb}{\sqrt{2}}$	

Introducing atomic spin-orbit state assembly formula and Slater determinants

Slater determinant state key:

$$a=1\uparrow, b=1\downarrow, c=2\uparrow, d=2\downarrow$$

The simplest assembly:

$$\frac{1}{2} \left(\frac{|1,2\rangle + |2,1\rangle}{\sqrt{2}} \right) \left(\frac{|\uparrow,\downarrow\rangle - |\downarrow,\uparrow\rangle}{\sqrt{2}} \right)$$

$$\frac{1}{2} (|1\uparrow, 2\downarrow\rangle - |2\downarrow, 1\uparrow\rangle + |2\uparrow, 1\downarrow\rangle - |1\downarrow, 2\uparrow\rangle)$$

$$\frac{1}{2} (ad - da + cb - bc)$$

$$\frac{1}{2} \left(\frac{|1,2\rangle - |2,1\rangle}{\sqrt{2}} \right) \left(\frac{|\uparrow,\downarrow\rangle + |\downarrow,\uparrow\rangle}{\sqrt{2}} \right)$$

$$\frac{1}{2} (|1\uparrow, 2\downarrow\rangle - |2\downarrow, 1\uparrow\rangle - |2\uparrow, 1\downarrow\rangle + |1\downarrow, 2\uparrow\rangle)$$

$$\frac{1}{2} (ad - da - cb + bc)$$

	$\begin{array}{ c c } \hline 1 & 2 \\ \hline \end{array}$	$\begin{array}{ c } \hline \uparrow \\ \hline \downarrow \\ \hline \end{array}$	$\begin{array}{ c c } \hline 1 & \uparrow \\ \hline 2 & \downarrow \\ \hline \end{array}$
$\begin{array}{ c } \hline 1\uparrow \\ \hline \end{array}$	$\sqrt{\frac{1}{2}}$	$\sqrt{\frac{1}{2}}$	
$\begin{array}{ c } \hline 2\downarrow \\ \hline \end{array}$	$\sqrt{\frac{1}{2}}$	$\sqrt{\frac{1}{2}}$	
$\begin{array}{ c } \hline 1\downarrow \\ \hline \end{array}$	$-\sqrt{\frac{1}{2}}$	$\sqrt{\frac{1}{2}}$	
$\begin{array}{ c } \hline 2\uparrow \\ \hline \end{array}$	$\sqrt{\frac{1}{2}}$	$\sqrt{\frac{1}{2}}$	

	$\begin{array}{ c c } \hline 1 & 2 \\ \hline \end{array}$	$\begin{array}{ c } \hline \uparrow \\ \hline \downarrow \\ \hline \end{array}$	$\begin{array}{ c } \hline 1 \\ \hline 2 \\ \hline \end{array}$	$\begin{array}{ c c } \hline \uparrow & \downarrow \\ \hline \end{array}$
			$\frac{1}{2}(ad - da + cb - bc)$	$\frac{1}{2}(ad - da - cb + bc)$
$\begin{array}{ c } \hline 1\uparrow \\ \hline \end{array}$	$=$	a	$=$	$\frac{ad - da}{\sqrt{2}}$
$\begin{array}{ c } \hline 2\downarrow \\ \hline \end{array}$	$=$	d	$=$	$\frac{ad - da}{\sqrt{2}}$
$\begin{array}{ c } \hline 1\downarrow \\ \hline \end{array}$	$=$	b	$=$	$\frac{bc - cb}{\sqrt{2}}$
$\begin{array}{ c } \hline 2\uparrow \\ \hline \end{array}$	$=$	c	$=$	$\frac{bc - cb}{\sqrt{2}}$

Introducing atomic spin-orbit state assembly formula and Slater determinants

Slater determinant state key:

$$a=1\uparrow, b=1\downarrow, c=2\uparrow, d=2\downarrow$$

The simplest assembly:

$$\frac{1}{2} \left(\frac{|1,2\rangle + |2,1\rangle}{\sqrt{2}} \right) \left(\frac{|\uparrow,\downarrow\rangle - |\downarrow,\uparrow\rangle}{\sqrt{2}} \right)$$

$$\frac{1}{2} (|1\uparrow, 2\downarrow\rangle - |2\downarrow, 1\uparrow\rangle + |2\uparrow, 1\downarrow\rangle - |1\downarrow, 2\uparrow\rangle)$$

$$\frac{1}{2} (ad - da + cb - bc)$$

$$\frac{1}{2} \left(\frac{|1,2\rangle - |2,1\rangle}{\sqrt{2}} \right) \left(\frac{|\uparrow,\downarrow\rangle + |\downarrow,\uparrow\rangle}{\sqrt{2}} \right)$$

$$\frac{1}{2} (|1\uparrow, 2\downarrow\rangle - |2\downarrow, 1\uparrow\rangle - |2\uparrow, 1\downarrow\rangle + |1\downarrow, 2\uparrow\rangle)$$

$$\frac{1}{2} (ad - da - cb + bc)$$

	$\begin{array}{ c c } \hline 1 & 2 \\ \hline \end{array}$	$\begin{array}{ c } \hline \uparrow \\ \hline \downarrow \\ \hline \end{array}$	$\begin{array}{ c c } \hline 1 & \uparrow \\ \hline 2 & \downarrow \\ \hline \end{array}$
$\begin{array}{ c } \hline 1\uparrow \\ \hline \end{array}$	$\sqrt{\frac{1}{2}}$	$\sqrt{\frac{1}{2}}$	
$\begin{array}{ c } \hline 2\downarrow \\ \hline \end{array}$	$-\sqrt{\frac{1}{2}}$	$\sqrt{\frac{1}{2}}$	
$\begin{array}{ c } \hline 1\downarrow \\ \hline \end{array}$			$\sqrt{\frac{1}{2}}$
$\begin{array}{ c } \hline 2\uparrow \\ \hline \end{array}$			$\sqrt{\frac{1}{2}}$

	$\begin{array}{ c c } \hline 1 & 2 \\ \hline \end{array}$	$\begin{array}{ c } \hline \uparrow \\ \hline \downarrow \\ \hline \end{array}$	$\begin{array}{ c } \hline 1 \\ \hline 2 \\ \hline \end{array}$	$\begin{array}{ c c } \hline \uparrow & \downarrow \\ \hline \end{array}$
			$\frac{1}{2}(ad - da + cb - bc)$	$\frac{1}{2}(ad - da - cb + bc)$
$\begin{array}{ c } \hline 1\uparrow \\ \hline \end{array}$	$=$	a	$=$	$\frac{ad - da}{\sqrt{2}}$
$\begin{array}{ c } \hline 2\downarrow \\ \hline \end{array}$	$=$	d	$=$	$\frac{1}{2} \frac{1}{\sqrt{2}} + \frac{1}{2} \frac{1}{\sqrt{2}} = \sqrt{\frac{1}{2}}$
$\begin{array}{ c } \hline 1\downarrow \\ \hline \end{array}$	$=$	b	$=$	$\frac{bc - cb}{\sqrt{2}}$
$\begin{array}{ c } \hline 2\uparrow \\ \hline \end{array}$	$=$	c	$=$	$\frac{bc - cb}{\sqrt{2}}$

Introducing atomic spin-orbit state assembly formula and Slater determinants

Slater determinant state key:

$$a=1\uparrow, b=1\downarrow, c=2\uparrow, d=2\downarrow$$

The simplest assembly:

$$\frac{1}{2} \left(\frac{|1,2\rangle + |2,1\rangle}{\sqrt{2}} \right) \left(\frac{|\uparrow,\downarrow\rangle - |\downarrow,\uparrow\rangle}{\sqrt{2}} \right)$$

$$\frac{1}{2} (|1\uparrow, 2\downarrow\rangle - |2\downarrow, 1\uparrow\rangle + |2\uparrow, 1\downarrow\rangle - |1\downarrow, 2\uparrow\rangle)$$

$$\frac{1}{2} (ad - da + cb - bc)$$

$$\frac{1}{2} \left(\frac{|1,2\rangle - |2,1\rangle}{\sqrt{2}} \right) \left(\frac{|\uparrow,\downarrow\rangle + |\downarrow,\uparrow\rangle}{\sqrt{2}} \right)$$

$$\frac{1}{2} (|1\uparrow, 2\downarrow\rangle - |2\downarrow, 1\uparrow\rangle - |2\uparrow, 1\downarrow\rangle + |1\downarrow, 2\uparrow\rangle)$$

$$\frac{1}{2} (ad - da - cb + bc)$$

	$\begin{array}{ c c } \hline 1 & 2 \\ \hline \end{array}$	$\begin{array}{ c } \hline \uparrow \\ \hline \downarrow \\ \hline \end{array}$	$\begin{array}{ c c } \hline 1 & \uparrow \downarrow \\ \hline 2 & \\ \hline \end{array}$
$\begin{array}{ c } \hline 1\uparrow \\ \hline 2\downarrow \\ \hline \end{array}$	$\sqrt{\frac{1}{2}}$		$\sqrt{\frac{1}{2}}$
$\begin{array}{ c } \hline 1\downarrow \\ \hline 2\uparrow \\ \hline \end{array}$	$-\sqrt{\frac{1}{2}}$		$\sqrt{\frac{1}{2}}$

	$\begin{array}{ c c } \hline 1 & 2 \\ \hline \end{array}$	$\begin{array}{ c } \hline \uparrow \\ \hline \downarrow \\ \hline \end{array}$	$\begin{array}{ c } \hline 1 \\ \hline 2 \\ \hline \end{array}$	$\begin{array}{ c c } \hline \uparrow & \downarrow \\ \hline \end{array}$	
			$\frac{1}{2}(ad - da + cb - bc)$	$\frac{1}{2}(ad - da - cb + bc)$	
$\begin{array}{ c } \hline 1\uparrow \\ \hline 2\downarrow \\ \hline \end{array}$	$=$	a	$d = \frac{ad - da}{\sqrt{2}}$	$\frac{1}{2} \frac{1}{\sqrt{2}} + \frac{1}{2} \frac{1}{\sqrt{2}} = \sqrt{\frac{1}{2}}$	$\frac{1}{2} \frac{1}{\sqrt{2}} + \frac{1}{2} \frac{1}{\sqrt{2}} = \sqrt{\frac{1}{2}}$
$\begin{array}{ c } \hline 1\downarrow \\ \hline 2\uparrow \\ \hline \end{array}$	$=$	b	$c = \frac{bc - cb}{\sqrt{2}}$		

Introducing atomic spin-orbit state assembly formula and Slater determinants

Slater determinant state key:

$$a=1\uparrow, b=1\downarrow, c=2\uparrow, d=2\downarrow$$

The simplest assembly:

$$\frac{1}{2} \left(\frac{|1,2\rangle + |2,1\rangle}{\sqrt{2}} \right) \left(\frac{|\uparrow,\downarrow\rangle - |\downarrow,\uparrow\rangle}{\sqrt{2}} \right)$$

$$\frac{1}{2} (|1\uparrow, 2\downarrow\rangle - |2\downarrow, 1\uparrow\rangle + |2\uparrow, 1\downarrow\rangle - |1\downarrow, 2\uparrow\rangle)$$

$$\frac{1}{2} (ad - da + cb - bc)$$

$$\frac{1}{2} \left(\frac{|1,2\rangle - |2,1\rangle}{\sqrt{2}} \right) \left(\frac{|\uparrow,\downarrow\rangle + |\downarrow,\uparrow\rangle}{\sqrt{2}} \right)$$

$$\frac{1}{2} (|1\uparrow, 2\downarrow\rangle - |2\downarrow, 1\uparrow\rangle - |2\uparrow, 1\downarrow\rangle + |1\downarrow, 2\uparrow\rangle)$$

$$\frac{1}{2} (ad - da - cb + bc)$$

	$\begin{array}{ c c } \hline 1 & 2 \\ \hline \end{array}$	$\begin{array}{ c } \hline \uparrow \\ \hline \downarrow \\ \hline \end{array}$	$\begin{array}{ c c } \hline 1 & \uparrow \\ \hline 2 & \downarrow \\ \hline \end{array}$
$\begin{array}{ c } \hline 1\uparrow \\ \hline \end{array}$	$\sqrt{\frac{1}{2}}$	$\sqrt{\frac{1}{2}}$	
$\begin{array}{ c } \hline 2\downarrow \\ \hline \end{array}$	$\sqrt{\frac{1}{2}}$	$\sqrt{\frac{1}{2}}$	
$\begin{array}{ c } \hline 1\downarrow \\ \hline \end{array}$	$-\sqrt{\frac{1}{2}}$	$\sqrt{\frac{1}{2}}$	
$\begin{array}{ c } \hline 2\uparrow \\ \hline \end{array}$	$-\sqrt{\frac{1}{2}}$	$\sqrt{\frac{1}{2}}$	

	$\begin{array}{ c c } \hline 1 & 2 \\ \hline \end{array}$	$\begin{array}{ c } \hline \uparrow \\ \hline \downarrow \\ \hline \end{array}$	$\begin{array}{ c } \hline 1 \\ \hline 2 \\ \hline \end{array}$	$\begin{array}{ c c } \hline \uparrow & \downarrow \\ \hline \end{array}$
			$\frac{1}{2}(ad - da + cb - bc)$	$\frac{1}{2}(ad - da - cb + bc)$
$\begin{array}{ c } \hline 1\uparrow \\ \hline \end{array}$	$= a$	$= d = \frac{ad - da}{\sqrt{2}}$	$\frac{1}{2} \frac{1}{\sqrt{2}} + \frac{1}{2} \frac{1}{\sqrt{2}} = \sqrt{\frac{1}{2}}$	$\frac{1}{2} \frac{1}{\sqrt{2}} + \frac{1}{2} \frac{1}{\sqrt{2}} = \sqrt{\frac{1}{2}}$
$\begin{array}{ c } \hline 1\downarrow \\ \hline \end{array}$	$= b$	$= c = \frac{bc - cb}{\sqrt{2}}$	$-\frac{1}{2} \frac{1}{\sqrt{2}} - \frac{1}{2} \frac{1}{\sqrt{2}} = -\sqrt{\frac{1}{2}}$	$-\frac{1}{2} \frac{1}{\sqrt{2}} - \frac{1}{2} \frac{1}{\sqrt{2}} = -\sqrt{\frac{1}{2}}$

Introducing atomic spin-orbit state assembly formula and Slater determinants

Slater determinant state key:

$$a=1\uparrow, b=1\downarrow, c=2\uparrow, d=2\downarrow$$

The simplest assembly:

$$\frac{1}{2} \left(\frac{|1,2\rangle + |2,1\rangle}{\sqrt{2}} \right) \left(\frac{|\uparrow,\downarrow\rangle - |\downarrow,\uparrow\rangle}{\sqrt{2}} \right)$$

$$\frac{1}{2} (|1\uparrow, 2\downarrow\rangle - |2\downarrow, 1\uparrow\rangle + |2\uparrow, 1\downarrow\rangle - |1\downarrow, 2\uparrow\rangle)$$

$$\frac{1}{2} (ad - da + cb - bc)$$

$$\frac{1}{2} \left(\frac{|1,2\rangle - |2,1\rangle}{\sqrt{2}} \right) \left(\frac{|\uparrow,\downarrow\rangle + |\downarrow,\uparrow\rangle}{\sqrt{2}} \right)$$

$$\frac{1}{2} (|1\uparrow, 2\downarrow\rangle - |2\downarrow, 1\uparrow\rangle - |2\uparrow, 1\downarrow\rangle + |1\downarrow, 2\uparrow\rangle)$$

$$\frac{1}{2} (ad - da - cb + bc)$$

	$\begin{array}{ c c } \hline 1 & 2 \\ \hline \end{array}$	$\begin{array}{ c } \hline \uparrow \\ \hline \downarrow \\ \hline \end{array}$	$\begin{array}{ c c } \hline 1 & \uparrow \\ \hline 2 & \downarrow \\ \hline \end{array}$
$\begin{array}{ c } \hline 1\uparrow \\ \hline \end{array}$	$\frac{1}{\sqrt{2}}$	$\frac{1}{\sqrt{2}}$	$\frac{1}{\sqrt{2}}$
$\begin{array}{ c } \hline 2\downarrow \\ \hline \end{array}$	$\frac{1}{\sqrt{2}}$	$\frac{1}{\sqrt{2}}$	$\frac{1}{\sqrt{2}}$
$\begin{array}{ c } \hline 1\downarrow \\ \hline \end{array}$	$-\frac{1}{\sqrt{2}}$	$\frac{1}{\sqrt{2}}$	$\frac{1}{\sqrt{2}}$
$\begin{array}{ c } \hline 2\uparrow \\ \hline \end{array}$	$-\frac{1}{\sqrt{2}}$	$\frac{1}{\sqrt{2}}$	$\frac{1}{\sqrt{2}}$

	$\begin{array}{ c c } \hline 1 & 2 \\ \hline \end{array}$	$\begin{array}{ c } \hline \uparrow \\ \hline \downarrow \\ \hline \end{array}$	$\begin{array}{ c } \hline 1 \\ \hline 2 \\ \hline \end{array}$	$\begin{array}{ c c } \hline \uparrow & \downarrow \\ \hline \end{array}$
		$\frac{1}{2}(ad - da + cb - bc)$	$\frac{1}{2}(ad - da - cb + bc)$	
$\begin{array}{ c } \hline 1\uparrow \\ \hline \end{array}$	$= a$	$\frac{ad - da}{\sqrt{2}}$	$\frac{1}{2} \frac{1}{\sqrt{2}} + \frac{1}{2} \frac{1}{\sqrt{2}} = \frac{1}{\sqrt{2}}$	$\frac{1}{2} \frac{1}{\sqrt{2}} + \frac{1}{2} \frac{1}{\sqrt{2}} = \frac{1}{\sqrt{2}}$
$\begin{array}{ c } \hline 1\downarrow \\ \hline \end{array}$	$= b$	$\frac{bc - cb}{\sqrt{2}}$	$-\frac{1}{2} \frac{1}{\sqrt{2}} - \frac{1}{2} \frac{1}{\sqrt{2}} = -\frac{1}{\sqrt{2}}$	$\frac{1}{2} \frac{1}{\sqrt{2}} + \frac{1}{2} \frac{1}{\sqrt{2}} = \frac{1}{\sqrt{2}}$
$\begin{array}{ c } \hline 2\uparrow \\ \hline \end{array}$	$= c$	$\frac{bc - cb}{\sqrt{2}}$	$-\frac{1}{2} \frac{1}{\sqrt{2}} - \frac{1}{2} \frac{1}{\sqrt{2}} = -\frac{1}{\sqrt{2}}$	$\frac{1}{2} \frac{1}{\sqrt{2}} + \frac{1}{2} \frac{1}{\sqrt{2}} = \frac{1}{\sqrt{2}}$

Introducing atomic spin-orbit state assembly formula and Slater determinants

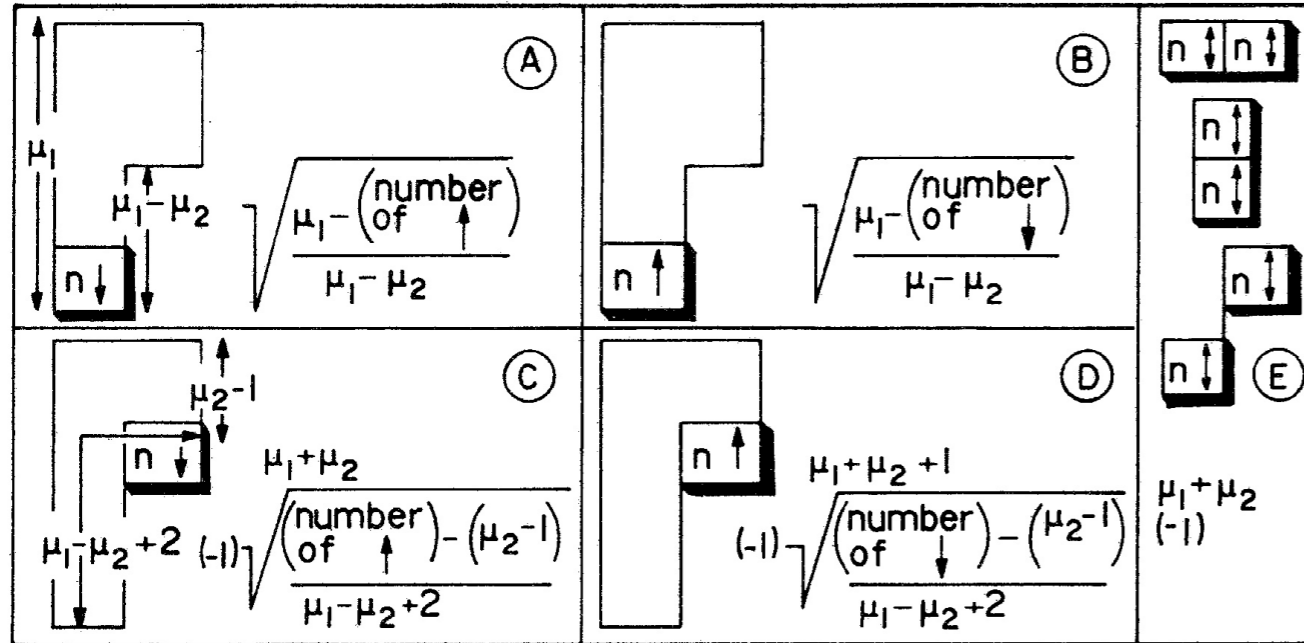

FIG. 5. Assembly formula for combining orbital and spin states. Each column state (Slater determinant) on the left-hand side of the sample table has a definite spin (arrow) on each orbital state (number). The formulas will give the overlap of this Slater state with a given orbital tableau state if we first write the spins within this orbital tableau state in exactly the same way. Then we proceed to remove boxes with numbered spins starting with the highest number(s). Each "removal" gives a factor depending on what is being removed and where (cases A-E). All of the numbers in the formulas refer to the condition of the tableau just before the box outlined in the figure is removed.

EXAMPLE :

$$\left| \begin{array}{|c|c|c|c|} \hline 1 & 2 & \uparrow & \uparrow \\ \hline 3 & & \downarrow & \\ \hline \end{array} \right\rangle \left| \begin{array}{|c|c|c|c|} \hline 1 & 3 & \uparrow & \uparrow \\ \hline 2 & & \downarrow & \\ \hline \end{array} \right\rangle \left| \begin{array}{|c|c|} \hline 1 & \\ \hline 2 & \uparrow \uparrow \downarrow \\ \hline 3 & \\ \hline \end{array} \right\rangle$$

1	3
2	
3	

Slater
determinants

$\begin{array}{ c } \hline 1 \uparrow \\ \hline \end{array}$	○	$-\sqrt{\frac{2}{3}}$	$\sqrt{\frac{1}{3}}$
$\begin{array}{ c } \hline 2 \uparrow \\ \hline \end{array}$			
$\begin{array}{ c } \hline 3 \downarrow \\ \hline \end{array}$			
$\begin{array}{ c } \hline 1 \uparrow \\ \hline \end{array}$	$\sqrt{\frac{1}{2}}$	$\sqrt{\frac{1}{6}}$	$\sqrt{\frac{1}{3}}$
$\begin{array}{ c } \hline 2 \downarrow \\ \hline \end{array}$			
$\begin{array}{ c } \hline 3 \uparrow \\ \hline \end{array}$			
$\begin{array}{ c } \hline 1 \downarrow \\ \hline \end{array}$	$-\sqrt{\frac{1}{2}}$	$\sqrt{\frac{1}{6}}$	$\sqrt{\frac{1}{3}}$
$\begin{array}{ c } \hline 2 \uparrow \\ \hline \end{array}$			
$\begin{array}{ c } \hline 3 \uparrow \\ \hline \end{array}$			

$$-\sqrt{\frac{1}{2}} = \sqrt{\frac{1}{1}} \cdot -\sqrt{\frac{1}{2}} \cdot 1$$

$\begin{array}{|c|c|} \hline 1 \downarrow & 2 \uparrow \\ \hline 3 \uparrow & \\ \hline \end{array} \textcircled{B}$
 $\begin{array}{|c|c|} \hline 1 \downarrow & 2 \uparrow \\ \hline & \\ \hline \end{array} \textcircled{D}$
 $\begin{array}{|c|} \hline 1 \downarrow \\ \hline \end{array}$

Introducing atomic spin-orbit state assembly formula and Slater determinants

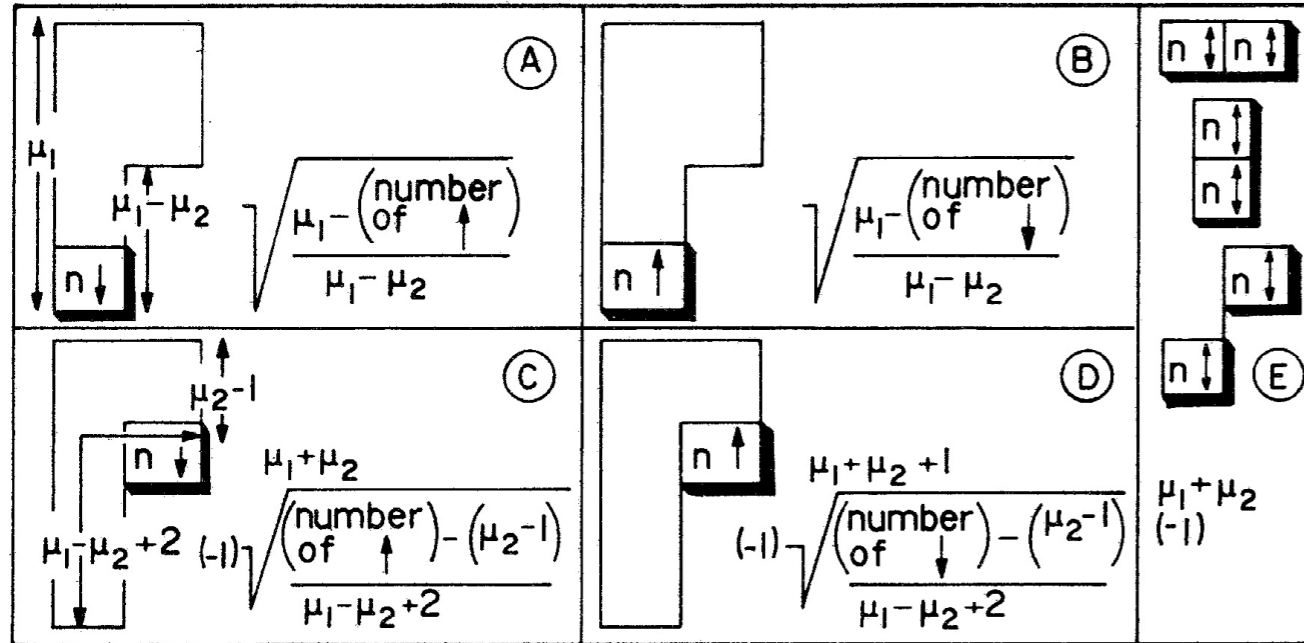
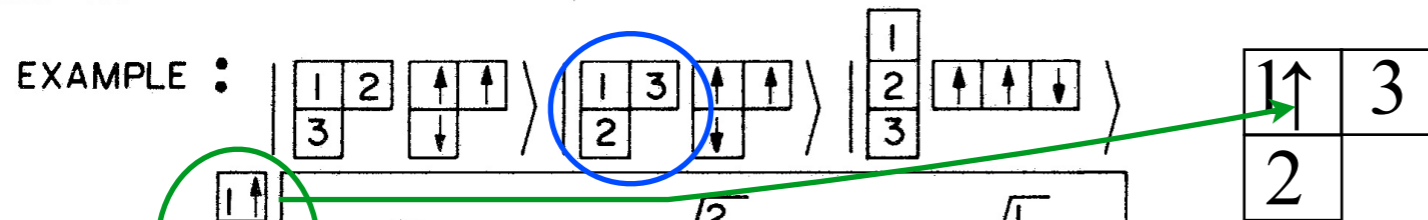

FIG. 5. Assembly formula for combining orbital and spin states. Each column state (Slater determinant) on the left-hand side of the sample table has a definite spin (arrow) on each orbital state (number). The formulas will give the overlap of this Slater state with a given orbital tableau state if we first write the spins within this orbital tableau in exactly the same way. Then we proceed to remove boxes with numbered spins starting with the highest number(s). Each "removal" gives a factor depending on what is being removed and where (cases A-E). All of the numbers in the formulas refer to the condition of the tableau just before the box outlined in the figure is removed.



Slater determinants

1↑	○	$-\sqrt{\frac{2}{3}}$	$\sqrt{\frac{1}{3}}$
2↑			
3↓			
1↑	$\sqrt{\frac{1}{2}}$	$\sqrt{\frac{1}{6}}$	$\sqrt{\frac{1}{3}}$
2↓			
3↑			
1↓	$-\sqrt{\frac{1}{2}}$	$\sqrt{\frac{1}{6}}$	$\sqrt{\frac{1}{3}}$
2↑			
3↑			

$$-\sqrt{\frac{1}{2}} = \sqrt{\frac{1}{1}} \cdot -\sqrt{\frac{1}{2}} \cdot 1$$

Introducing atomic spin-orbit state assembly formula and Slater determinants

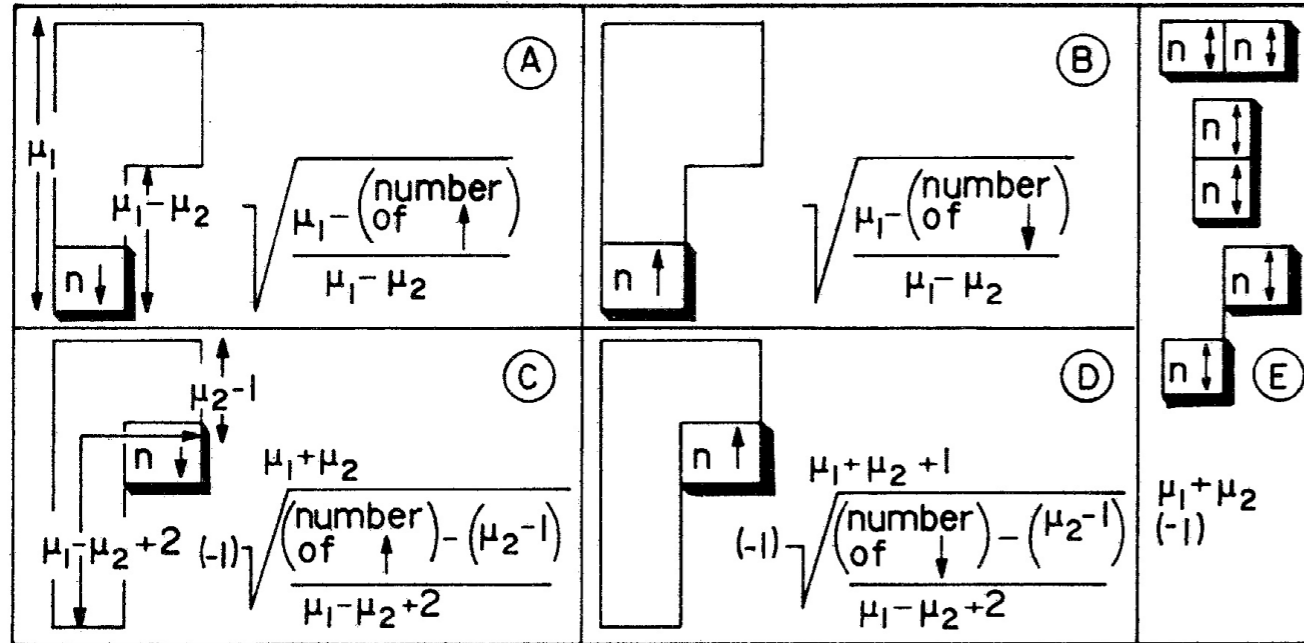
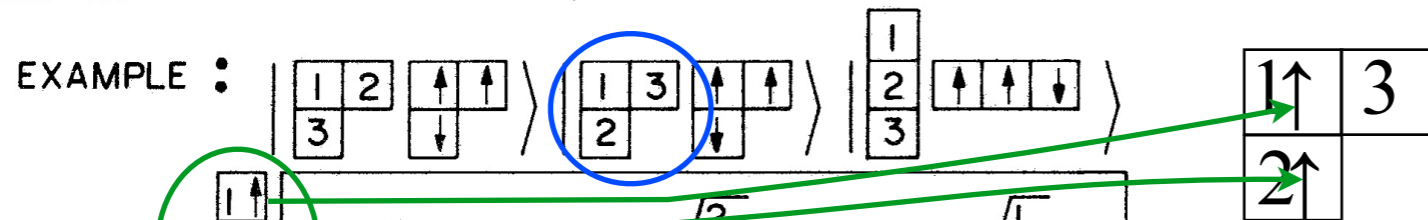

FIG. 5. Assembly formula for combining orbital and spin states. Each column state (Slater determinant) on the left-hand side of the sample table has a definite spin (arrow) on each orbital state (number). The formulas will give the overlap of this Slater state with a given orbital tableau state if we first write the spins within this orbital tableau state in exactly the same way. Then we proceed to remove boxes with numbered spins starting with the highest number(s). Each "removal" gives a factor depending on what is being removed and where (cases A-E). All of the numbers in the formulas refer to the condition of the tableau just before the box outlined in the figure is removed.



Slater determinants

1↑	○	$-\sqrt{\frac{2}{3}}$	$\sqrt{\frac{1}{3}}$
2↑			
3↓			
1↑	$\sqrt{\frac{1}{2}}$	$\sqrt{\frac{1}{6}}$	$\sqrt{\frac{1}{3}}$
2↓			
3↑			
1↓	$-\sqrt{\frac{1}{2}}$	$\sqrt{\frac{1}{6}}$	$\sqrt{\frac{1}{3}}$
2↑			
3↑			

$$-\sqrt{\frac{1}{2}} = \sqrt{\frac{1}{1}} \cdot -\sqrt{\frac{1}{2}} \cdot 1$$

Introducing atomic spin-orbit state assembly formula and Slater determinants

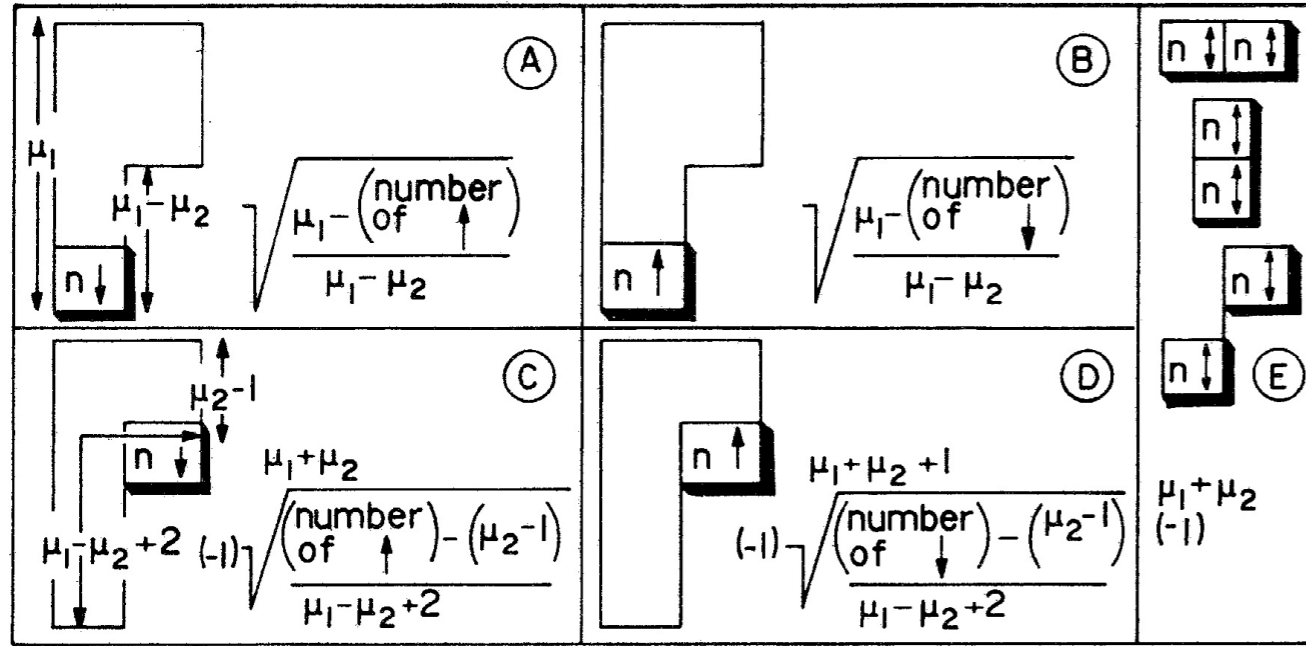

FIG. 5. Assembly formula for combining orbital and spin states. Each column state (Slater determinant) on the left-hand side of the sample table has a definite spin (arrow) on each orbital state (number). The formulas will give the overlap of this Slater state with a given orbital tableau state if we first write the spins within this orbital tableau in exactly the same way. Then we proceed to remove boxes with numbered spins starting with the highest number(s). Each “removal” gives a factor depending on what is being removed and where (cases A–E). All of the numbers in the formulas refer to the condition of the tableau just before the box outlined in the figure is removed.

EXAMPLE :

1	2	↑	↑	1	3	↑	↑	1	↑	↑	↓
3		↓		2	↓			2	↑	↑	↓

1	↑	○	$-\sqrt{\frac{2}{3}}$	$\sqrt{\frac{1}{3}}$
2	↑			
3	↓			
1	↑	$\sqrt{\frac{1}{2}}$	$\sqrt{\frac{1}{6}}$	$\sqrt{\frac{1}{3}}$
2	↓			
3	↑			
1	↓	$-\sqrt{\frac{1}{2}}$	$\sqrt{\frac{1}{6}}$	$\sqrt{\frac{1}{3}}$
2	↑			
3	↑			

$-\sqrt{\frac{1}{2}} = \sqrt{\frac{1}{1}} \cdot -\sqrt{\frac{1}{2}} \cdot 1$

Introducing atomic spin-orbit state assembly formula and Slater determinants

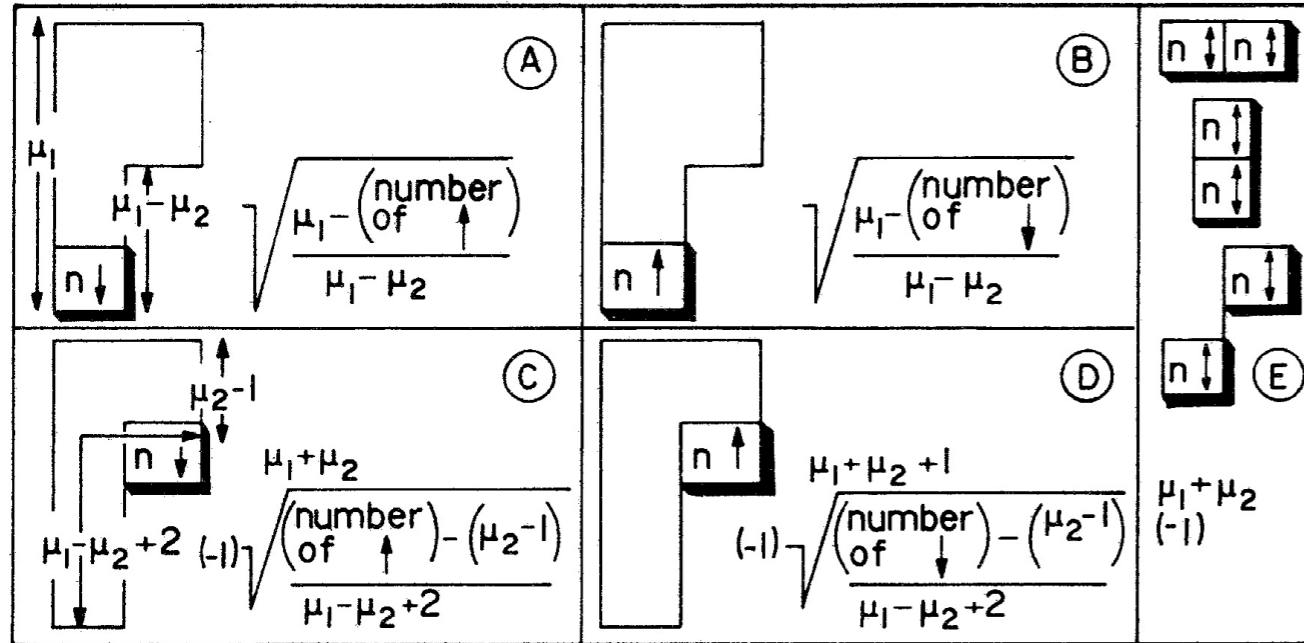
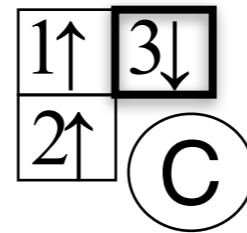

FIG. 5. Assembly formula for combining orbital and spin states. Each column state (Slater determinant) on the left-hand side of the sample table has a definite spin (arrow) on each orbital state (number). The formulas will give the overlap of this Slater state with a given orbital tableau state if we first write the spins within this orbital tableau in exactly the same way. Then we proceed to remove boxes with numbered spins starting with the highest number(s). Each "removal" gives a factor depending on what is being removed and where (cases A-E). All of the numbers in the formulas refer to the condition of the tableau just before the box outlined in the figure is removed.

EXAMPLE : $\left| \begin{array}{|c|c|c|c|} \hline 1 & 2 & \uparrow & \uparrow \\ \hline 3 & & \downarrow & \\ \hline \end{array} \right\rangle \left| \begin{array}{|c|c|c|c|} \hline 1 & 3 & \uparrow & \uparrow \\ \hline 2 & & \downarrow & \\ \hline \end{array} \right\rangle \left| \begin{array}{|c|c|c|} \hline 1 \\ \hline 2 & \uparrow & \uparrow & \downarrow \\ \hline 3 \\ \hline \end{array} \right\rangle$



Slater
determinants

$\begin{array}{ c } \hline 1 \uparrow \\ \hline 2 \uparrow \\ \hline 3 \downarrow \\ \hline \end{array}$	0	$-\sqrt{\frac{2}{3}}$	$\sqrt{\frac{1}{3}}$
$\begin{array}{ c } \hline 1 \uparrow \\ \hline 2 \downarrow \\ \hline 3 \uparrow \\ \hline \end{array}$	$\sqrt{\frac{1}{2}}$	$\sqrt{\frac{1}{6}}$	$\sqrt{\frac{1}{3}}$
$\begin{array}{ c } \hline 1 \downarrow \\ \hline 2 \uparrow \\ \hline 3 \uparrow \\ \hline \end{array}$	$-\sqrt{\frac{1}{2}}$	$\sqrt{\frac{1}{6}}$	$\sqrt{\frac{1}{3}}$

$-\sqrt{\frac{1}{2}} = \sqrt{\frac{1}{1}} \cdot -\sqrt{\frac{1}{2}} \cdot 1$

Introducing atomic spin-orbit state assembly formula and Slater determinants

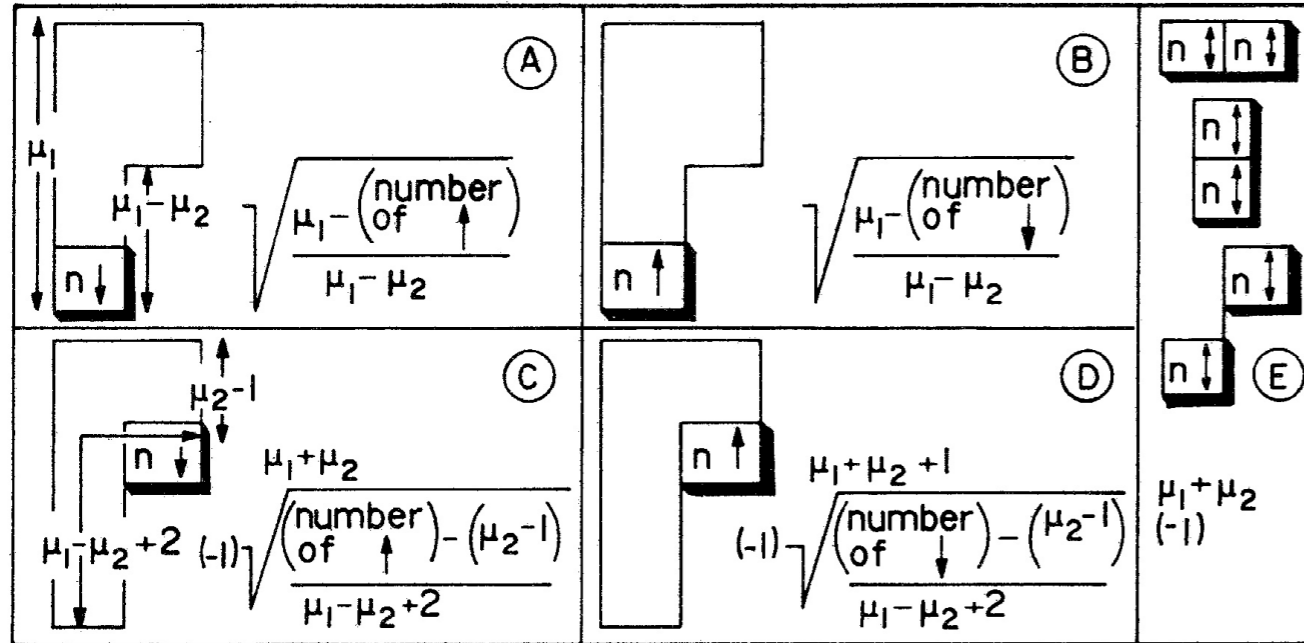

FIG. 5. Assembly formula for combining orbital and spin states. Each column state (Slater determinant) on the left-hand side of the sample table has a definite spin (arrow) on each orbital state (number). The formulas will give the overlap of this Slater state with a given orbital tableau state if we first write the spins within this orbital tableau in exactly the same way. Then we proceed to remove boxes with numbered spins starting with the highest number(s). Each “removal” gives a factor depending on what is being removed and where (cases A–E). All of the numbers in the formulas refer to the condition of the tableau just before the box outlined in the figure is removed.

EXAMPLE :

$$\left| \begin{array}{|c|c|c|c|} \hline 1 & 2 & \uparrow & \uparrow \\ \hline 3 & & \downarrow & \\ \hline \end{array} \right\rangle \left| \begin{array}{|c|c|c|c|} \hline 1 & 3 & \uparrow & \uparrow \\ \hline 2 & & \downarrow & \\ \hline \end{array} \right\rangle \left| \begin{array}{|c|c|c|} \hline 1 \\ \hline 2 & \uparrow & \uparrow & \downarrow \\ \hline 3 \\ \hline \end{array} \right\rangle$$

$$\left| \begin{array}{|c|c|} \hline 1\uparrow & 3\downarrow \\ \hline 2\uparrow & \\ \hline \end{array} \right\rangle \begin{matrix} \text{C} \\ (-) \sqrt{\frac{2-0}{3}} \\ \mu_1=2, \mu_2=1 \end{matrix}$$

Slater
determinants

$\begin{array}{ c } \hline 1\uparrow \\ \hline 2\uparrow \\ \hline 3\downarrow \\ \hline \end{array}$	0	$-\sqrt{\frac{2}{3}}$	$\sqrt{\frac{1}{3}}$
$\begin{array}{ c } \hline 1\uparrow \\ \hline 2\downarrow \\ \hline 3\uparrow \\ \hline \end{array}$	$\sqrt{\frac{1}{2}}$	$\sqrt{\frac{1}{6}}$	$\sqrt{\frac{1}{3}}$
$\begin{array}{ c } \hline 1\downarrow \\ \hline 2\uparrow \\ \hline 3\uparrow \\ \hline \end{array}$	$-\sqrt{\frac{1}{2}}$	$\sqrt{\frac{1}{6}}$	$\sqrt{\frac{1}{3}}$

$$-\sqrt{\frac{1}{2}} = \sqrt{\frac{1}{1}} \cdot -\sqrt{\frac{1}{2}} \cdot 1$$

Introducing atomic spin-orbit state assembly formula and Slater determinants

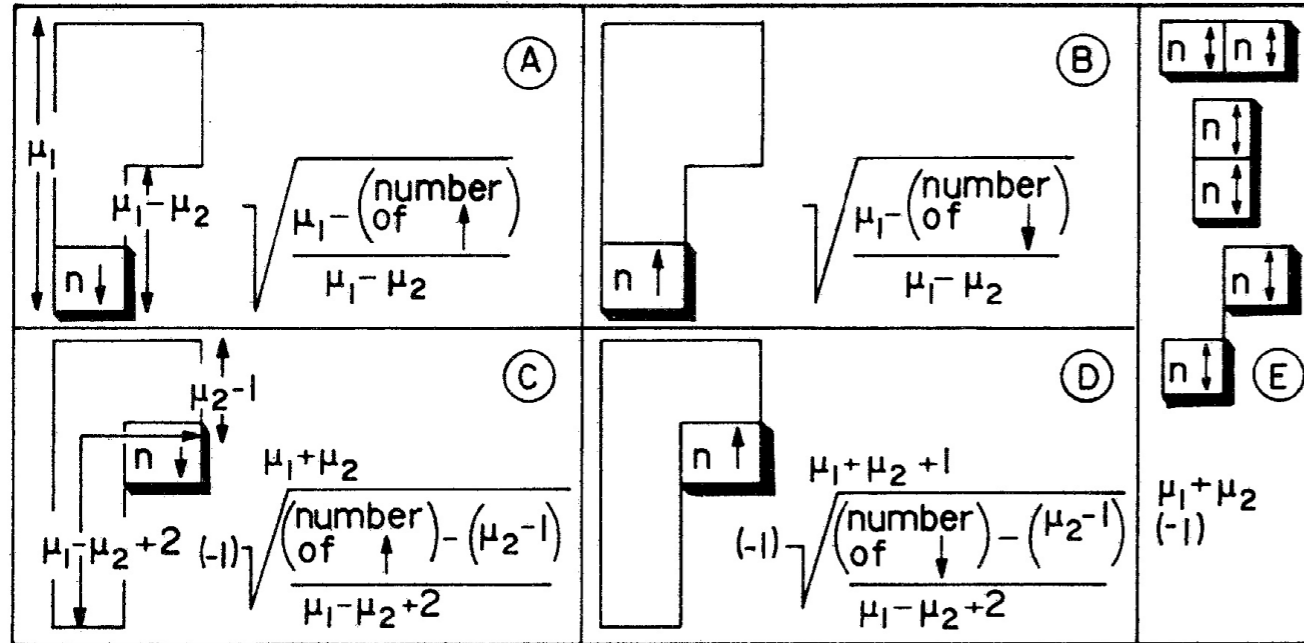

FIG. 5. Assembly formula for combining orbital and spin states. Each column state (Slater determinant) on the left-hand side of the sample table has a definite spin (arrow) on each orbital state (number). The formulas will give the overlap of this Slater state with a given orbital tableau state if we first write the spins within this orbital tableau state in exactly the same way. Then we proceed to remove boxes with numbered spins starting with the highest number(s). Each "removal" gives a factor depending on what is being removed and where (cases A-E). All of the numbers in the formulas refer to the condition of the tableau just before the box outlined in the figure is removed.

EXAMPLE :

$$\left| \begin{array}{|c|c|c|c|} \hline 1 & 2 & \uparrow & \uparrow \\ \hline 3 & & \downarrow & \\ \hline \end{array} \right\rangle \left| \begin{array}{|c|c|c|c|} \hline 1 & 3 & \uparrow & \uparrow \\ \hline 2 & & \downarrow & \\ \hline \end{array} \right\rangle \left| \begin{array}{|c|c|c|c|} \hline 1 & & & \\ \hline 2 & \uparrow & \uparrow & \downarrow \\ \hline 3 & & & \\ \hline \end{array} \right\rangle$$

Slater
determinants

$\begin{array}{ c } \hline 1 \uparrow \\ \hline 2 \uparrow \\ \hline 3 \downarrow \\ \hline \end{array}$	0	$-\sqrt{\frac{2}{3}}$	$\sqrt{\frac{1}{3}}$
$\begin{array}{ c } \hline 1 \uparrow \\ \hline 2 \downarrow \\ \hline 3 \uparrow \\ \hline \end{array}$	$\sqrt{\frac{1}{2}}$	$\sqrt{\frac{1}{6}}$	$\sqrt{\frac{1}{3}}$
$\begin{array}{ c } \hline 1 \downarrow \\ \hline 2 \uparrow \\ \hline 3 \uparrow \\ \hline \end{array}$	$-\sqrt{\frac{1}{2}}$	$\sqrt{\frac{1}{6}}$	$\sqrt{\frac{1}{3}}$

$$\begin{array}{|c|c|} \hline 1 \uparrow & 3 \downarrow \\ \hline 2 \uparrow & \\ \hline \end{array} \begin{array}{c} \text{C} \\ \mu_1=2, \mu_2=1 \end{array} (-) \sqrt{\frac{2-0}{3}} \begin{array}{|c|c|} \hline 1 \uparrow & \\ \hline 2 \uparrow & \\ \hline \end{array} \text{B}$$

$$-\sqrt{\frac{1}{2}} = \sqrt{\frac{1}{1}} \cdot (-\sqrt{\frac{1}{2}}) \cdot 1$$

Introducing atomic spin-orbit state assembly formula and Slater determinants

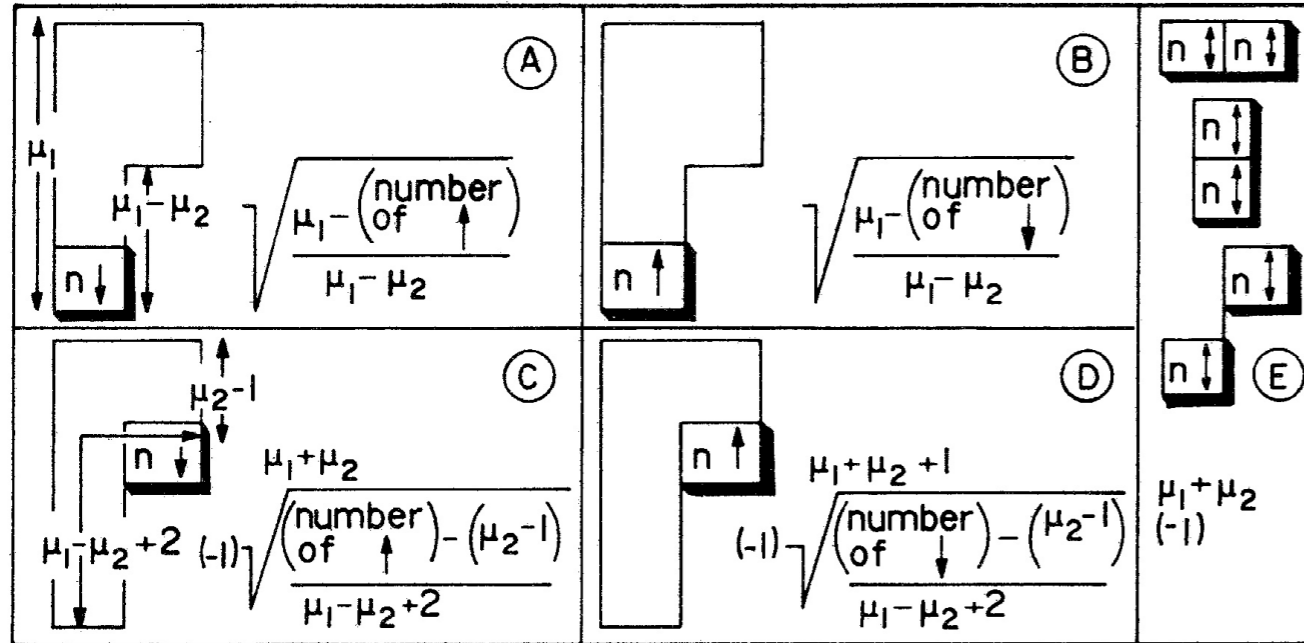

FIG. 5. Assembly formula for combining orbital and spin states. Each column state (Slater determinant) on the left-hand side of the sample table has a definite spin (arrow) on each orbital state (number). The formulas will give the overlap of this Slater state with a given orbital tableau state if we first write the spins within this orbital tableau in exactly the same way. Then we proceed to remove boxes with numbered spins starting with the highest number(s). Each “removal” gives a factor depending on what is being removed and where (cases A–E). All of the numbers in the formulas refer to the condition of the tableau just before the box outlined in the figure is removed.

EXAMPLE :

$$\left| \begin{array}{|c|c|c|c|} \hline 1 & 2 & \uparrow & \uparrow \\ \hline 3 & & \downarrow & \\ \hline \end{array} \right\rangle \left| \begin{array}{|c|c|c|c|} \hline 1 & 3 & \uparrow & \uparrow \\ \hline 2 & & \downarrow & \\ \hline \end{array} \right\rangle \left| \begin{array}{|c|c|c|c|} \hline 1 & & & \\ \hline 2 & \uparrow & \uparrow & \downarrow \\ \hline 3 & & & \\ \hline \end{array} \right\rangle$$

Slater
determinants

$\begin{array}{ c } \hline 1 \uparrow \\ \hline 2 \uparrow \\ \hline 3 \downarrow \\ \hline \end{array}$	○	$-\sqrt{\frac{2}{3}}$	$\sqrt{\frac{1}{3}}$
$\begin{array}{ c } \hline 1 \uparrow \\ \hline 2 \downarrow \\ \hline 3 \uparrow \\ \hline \end{array}$	$\sqrt{\frac{1}{2}}$	$\sqrt{\frac{1}{6}}$	$\sqrt{\frac{1}{3}}$
$\begin{array}{ c } \hline 1 \downarrow \\ \hline 2 \uparrow \\ \hline 3 \uparrow \\ \hline \end{array}$	$-\sqrt{\frac{1}{2}}$	$\sqrt{\frac{1}{6}}$	$\sqrt{\frac{1}{3}}$

$$\begin{array}{|c|c|} \hline 1 \uparrow & 3 \downarrow \\ \hline 2 \uparrow & \\ \hline \end{array} \textcircled{C} (-) \sqrt{\frac{2-0}{3}} \quad \mu_1=2, \mu_2=1$$

$$\begin{array}{|c|c|} \hline 1 \uparrow & \\ \hline 2 \uparrow & \\ \hline \end{array} \textcircled{B} (+) \sqrt{\frac{2-0}{2-0}} \quad \mu_1=2, \mu_2=0$$

$$-\sqrt{\frac{1}{2}} = \sqrt{\frac{1}{1}} \cdot -\sqrt{\frac{1}{2}} \cdot 1$$

Introducing atomic spin-orbit state assembly formula and Slater determinants

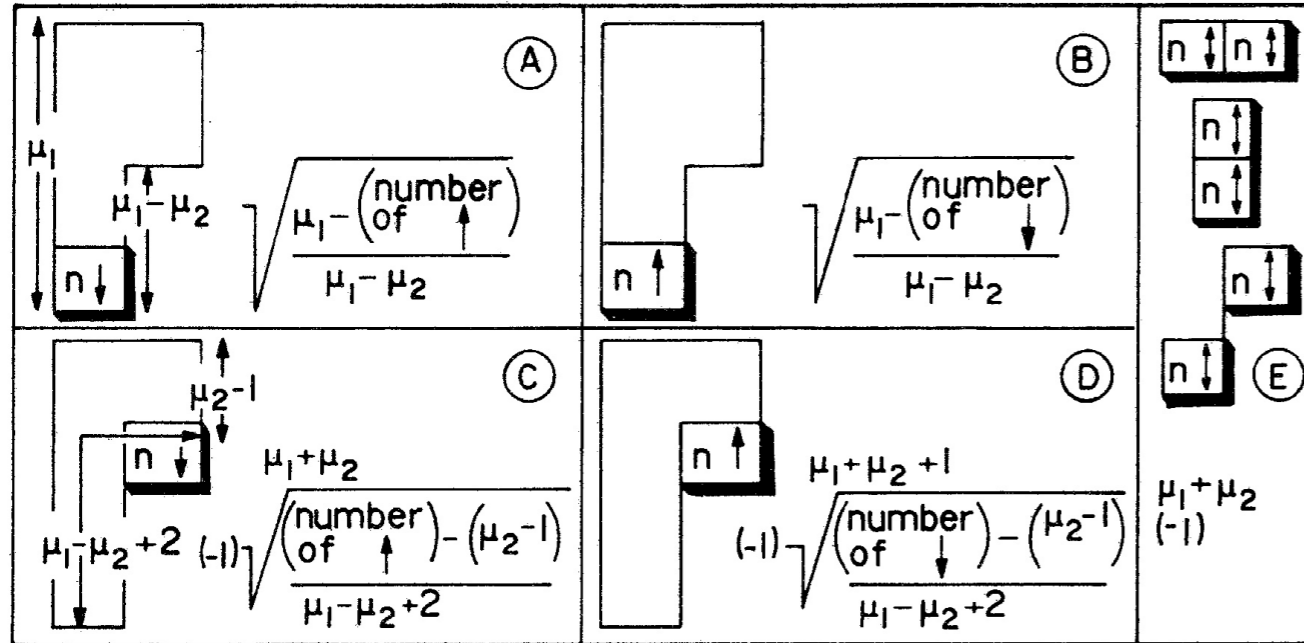

FIG. 5. Assembly formula for combining orbital and spin states. Each column state (Slater determinant) on the left-hand side of the sample table has a definite spin (arrow) on each orbital state (number). The formulas will give the overlap of this Slater state with a given orbital tableau state if we first write the spins within this orbital tableau in exactly the same way. Then we proceed to remove boxes with numbered spins starting with the highest number(s). Each “removal” gives a factor depending on what is being removed and where (cases A–E). All of the numbers in the formulas refer to the condition of the tableau just before the box outlined in the figure is removed.

EXAMPLE : $\left| \begin{array}{cc} 1 & 2 \\ 3 & \uparrow \uparrow \\ & \downarrow \end{array} \right\rangle \left| \begin{array}{cc} 1 & 3 \\ 2 & \uparrow \uparrow \\ & \downarrow \end{array} \right\rangle \left| \begin{array}{c} 1 \\ 2 \\ 3 \\ \uparrow \uparrow \downarrow \end{array} \right\rangle$

Slater
determinants

$\begin{array}{c} 1 \uparrow \\ 2 \uparrow \\ 3 \downarrow \end{array}$	○	$-\sqrt{\frac{2}{3}}$	$\sqrt{\frac{1}{3}}$
$\begin{array}{c} 1 \uparrow \\ 2 \downarrow \\ 3 \uparrow \end{array}$	$\sqrt{\frac{1}{2}}$	$\sqrt{\frac{1}{6}}$	$\sqrt{\frac{1}{3}}$
$\begin{array}{c} 1 \downarrow \\ 2 \uparrow \\ 3 \uparrow \end{array}$	$-\sqrt{\frac{1}{2}}$	$\sqrt{\frac{1}{6}}$	$\sqrt{\frac{1}{3}}$

$$\begin{array}{c} \begin{array}{c} 1 \uparrow \\ 2 \uparrow \end{array} \begin{array}{c} 3 \downarrow \\ \end{array} \begin{array}{c} (-) \sqrt{\frac{2-0}{3}} \\ \mu_1=2, \mu_2=1 \end{array} \begin{array}{c} 1 \uparrow \\ 2 \uparrow \end{array} \begin{array}{c} \\ \end{array} \begin{array}{c} (+) \sqrt{\frac{2-0}{2-0}} \\ \mu_1=2, \mu_2=0 \end{array} = (-) \sqrt{\frac{2}{3}} \end{array}$$

$$-\sqrt{\frac{1}{2}} = \sqrt{\frac{1}{1}} \cdot -\sqrt{\frac{1}{2}} \cdot 1$$

Introducing atomic spin-orbit state assembly formula and Slater determinants

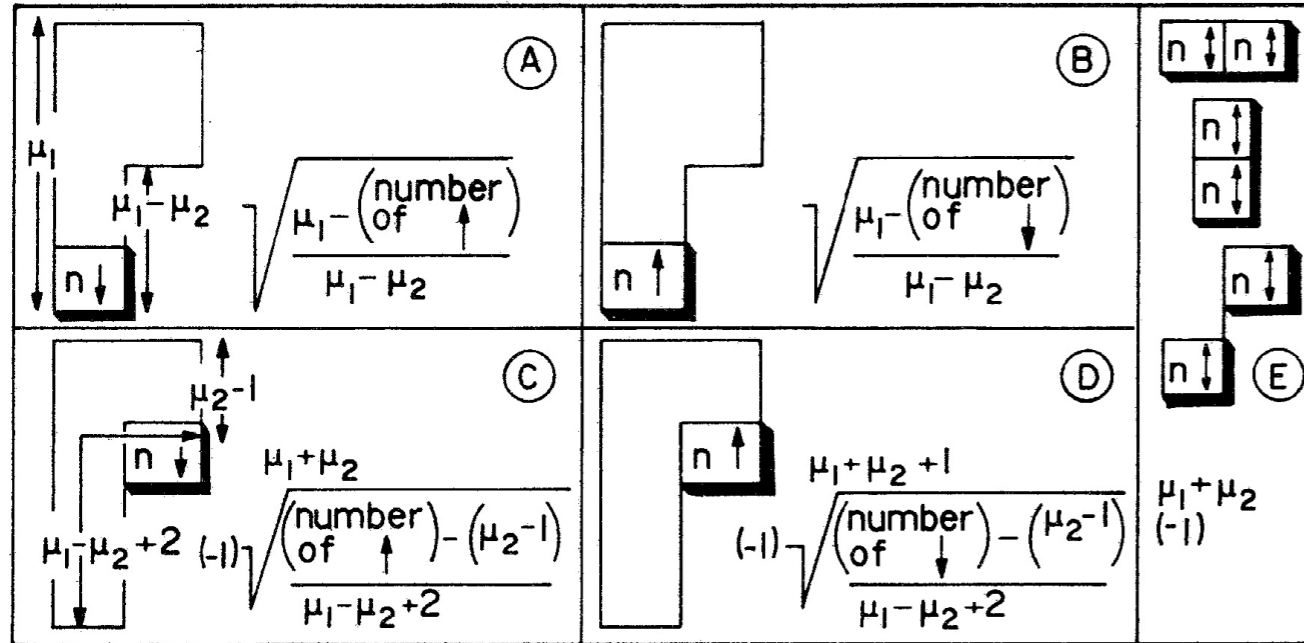

FIG. 5. Assembly formula for combining orbital and spin states. Each column state (Slater determinant) on the left-hand side of the sample table has a definite spin (arrow) on each orbital state (number). The formulas will give the overlap of this Slater state with a given orbital tableau state if we first write the spins within this orbital tableau in exactly the same way. Then we proceed to remove boxes with numbered spins starting with the highest number(s). Each “removal” gives a factor depending on what is being removed and where (cases A–E). All of the numbers in the formulas refer to the condition of the tableau just before the box outlined in the figure is removed.

EXAMPLE : $\left| \begin{array}{|c|c|c|} \hline 1 & 2 & \uparrow \uparrow \\ \hline 3 & & \downarrow \\ \hline \end{array} \right\rangle \left| \begin{array}{|c|c|c|} \hline 1 & 3 & \uparrow \uparrow \\ \hline 2 & & \downarrow \\ \hline \end{array} \right\rangle \left| \begin{array}{|c|c|} \hline 1 & \\ \hline 2 & \uparrow \uparrow \downarrow \\ \hline 3 & \\ \hline \end{array} \right\rangle$

Slater determinants

$\begin{array}{ c } \hline 1 \uparrow \\ \hline 2 \uparrow \\ \hline 3 \downarrow \\ \hline \end{array}$	○	$-\sqrt{\frac{2}{3}}$	$\sqrt{\frac{1}{3}}$
$\begin{array}{ c } \hline 1 \uparrow \\ \hline 2 \downarrow \\ \hline 3 \uparrow \\ \hline \end{array}$	$\sqrt{\frac{1}{2}}$	$\sqrt{\frac{1}{6}}$	$\sqrt{\frac{1}{3}}$
$\begin{array}{ c } \hline 1 \downarrow \\ \hline 2 \uparrow \\ \hline 3 \uparrow \\ \hline \end{array}$	$-\sqrt{\frac{1}{2}}$	$\sqrt{\frac{1}{6}}$	$\sqrt{\frac{1}{3}}$

$$\begin{array}{|c|c|} \hline 1 \uparrow & 3 \downarrow \\ \hline 2 \uparrow & \\ \hline \end{array} \textcircled{C} (-) \sqrt{\frac{2-0}{3}} \quad \begin{array}{|c|c|} \hline 1 \uparrow & \\ \hline 2 \uparrow & \\ \hline \end{array} \textcircled{B} (+) \sqrt{\frac{2-0}{2-0}} = (-) \sqrt{\frac{2}{3}}$$

$\mu_1=2, \mu_2=1$ $\mu_1=2, \mu_2=0$

$$\begin{array}{|c|c|} \hline 1 \uparrow & 3 \uparrow \\ \hline 2 \downarrow & \\ \hline \end{array} \textcircled{D} (+) \sqrt{\frac{1-0}{3}} \quad \begin{array}{|c|c|} \hline 1 \uparrow & \\ \hline 2 \downarrow & \\ \hline \end{array} \textcircled{A} (+) \sqrt{\frac{2-1}{2-0}} = (+) \sqrt{\frac{1}{6}}$$

$\mu_1=2, \mu_2=1$ $\mu_1=2, \mu_2=0$

$$-\sqrt{\frac{1}{2}} = \sqrt{\frac{1}{1}} \cdot -\sqrt{\frac{1}{2}} \cdot 1$$

$(S_3)^*(U(3)) \subset U(6)$ models of p^3 electronic spin-orbit states and couplings

$[2,1]$ tableau states lowered by $L_- = \sqrt{2}(E_{21} + E_{32})$

Top-(J,M) states thru mid-level states

$\ell=1$ p -shell LS states combined to states of definite J

J=3/2 at L=0 (4S). J=5/2 at L=2 (2D)

Clebsch-Gordon coupling; J=3/2 at L=2 (2D)

J=3/2 at L=1 (2P)

J=1/2 at L=1 (2P)

Spin-orbit state assembly formula and Slater determinants

The simplest assembly

 $\ell=1$ p -shell LSJ states transformed to Slater determinants from J=3/2 (4S)

Slater functions for J=5/2 (2D)

Slater functions for J=3/2 (2D)

Slater functions for J=3/2 (2P)

Slater functions for J=1/2 (2P)

Application to spin-orbit and entanglement break-up scattering

$\ell=1$ p -shell LSJ states transformed to Slater determinants from $J=3/2$ at $L=0$

$$\left| {}^4S_{J=\frac{3}{2}}^{\frac{3}{2}} \right\rangle = \begin{array}{|c|} \hline 1 \\ \hline 2 \\ \hline 3 \\ \hline \end{array} \uparrow\uparrow\uparrow, \quad \left| {}^4S_{J=\frac{3}{2}}^{\frac{1}{2}} \right\rangle = \begin{array}{|c|} \hline 1 \\ \hline 2 \\ \hline 3 \\ \hline \end{array} \uparrow\uparrow\downarrow, \quad \left| {}^4S_{J=\frac{3}{2}}^{\frac{-1}{2}} \right\rangle = \begin{array}{|c|} \hline 1 \\ \hline 2 \\ \hline 3 \\ \hline \end{array} \uparrow\downarrow\downarrow, \quad \left| {}^4S_{J=\frac{3}{2}}^{\frac{-3}{2}} \right\rangle = \begin{array}{|c|} \hline 1 \\ \hline 2 \\ \hline 3 \\ \hline \end{array} \downarrow\downarrow\downarrow$$

$M_J=3/2, \dots$

quartet 4S $J=\frac{3}{2}$,
 $M_J = \frac{+3}{2}, \frac{+1}{2}, \frac{-1}{2}, \frac{-3}{2}$.

Slater determinant state key:
 $a=1\uparrow, b=1\downarrow, c=2\uparrow, d=2\downarrow, e=3\uparrow, f=3\downarrow$

$\ell=1$ p -shell LSJ states transformed to Slater determinants from $J=3/2$ at $L=0$

$$\left| {}^4S_{J=\frac{3}{2}}^{\frac{3}{2}} \right\rangle = \begin{array}{|c|} \hline 1 \\ \hline 2 \\ \hline 3 \\ \hline \end{array} \uparrow\uparrow\uparrow \rangle, \left| {}^4S_{J=\frac{3}{2}}^{\frac{1}{2}} \right\rangle = \begin{array}{|c|} \hline 1 \\ \hline 2 \\ \hline 3 \\ \hline \end{array} \uparrow\uparrow\downarrow \rangle, \left| {}^4S_{J=\frac{3}{2}}^{\frac{-1}{2}} \right\rangle = \begin{array}{|c|} \hline 1 \\ \hline 2 \\ \hline 3 \\ \hline \end{array} \uparrow\downarrow\downarrow \rangle, \left| {}^4S_{J=\frac{3}{2}}^{\frac{-3}{2}} \right\rangle = \begin{array}{|c|} \hline 1 \\ \hline 2 \\ \hline 3 \\ \hline \end{array} \downarrow\downarrow\downarrow \rangle$$

quartet 4S $J=\frac{3}{2}$,
 $M_J = \frac{+3}{2}, \frac{+1}{2}, \frac{-1}{2}, \frac{-3}{2}$.

$$\left| {}^4S_{J=\frac{3}{2}}^{\frac{3}{2}} \right\rangle = \begin{array}{|c|} \hline 1\uparrow \\ \hline 2\uparrow \\ \hline 3\uparrow \\ \hline \end{array} \begin{array}{l} a \\ c \\ e \end{array} \rangle, \left| {}^4S_{J=\frac{3}{2}}^{\frac{1}{2}} \right\rangle = \begin{array}{|c|} \hline 1\uparrow \\ \hline 2\uparrow \\ \hline 3\downarrow \\ \hline \end{array} \begin{array}{l} a \\ c \\ f \end{array} \rangle, \left| {}^4S_{J=\frac{3}{2}}^{\frac{-1}{2}} \right\rangle = \begin{array}{|c|} \hline 1\uparrow \\ \hline 2\downarrow \\ \hline 3\downarrow \\ \hline \end{array} \begin{array}{l} a \\ d \\ f \end{array} \rangle, \left| {}^4S_{J=\frac{3}{2}}^{\frac{-3}{2}} \right\rangle = \begin{array}{|c|} \hline 1\downarrow \\ \hline 2\downarrow \\ \hline 3\downarrow \\ \hline \end{array} \begin{array}{l} b \\ d \\ f \end{array} \rangle$$

Slater determinant state key:
 $a=1\uparrow, b=1\downarrow, c=2\uparrow, d=2\downarrow, e=3\uparrow, f=3\downarrow$

$\ell=1$ p -shell LSJ states transformed to Slater determinants from $J=3/2$ at $L=0$

$M_J=3/2, \dots$

$$\left| {}^4S_{J=\frac{3}{2}}^{\frac{3}{2}} \right\rangle = \begin{array}{|c|} \hline 1 \\ \hline 2 \\ \hline 3 \\ \hline \end{array} \uparrow\uparrow\uparrow, \quad \left| {}^4S_{J=\frac{3}{2}}^{\frac{1}{2}} \right\rangle = \begin{array}{|c|} \hline 1 \\ \hline 2 \\ \hline 3 \\ \hline \end{array} \uparrow\uparrow\downarrow, \quad \left| {}^4S_{J=\frac{3}{2}}^{\frac{-1}{2}} \right\rangle = \begin{array}{|c|} \hline 1 \\ \hline 2 \\ \hline 3 \\ \hline \end{array} \uparrow\downarrow\downarrow, \quad \left| {}^4S_{J=\frac{3}{2}}^{\frac{-3}{2}} \right\rangle = \begin{array}{|c|} \hline 1 \\ \hline 2 \\ \hline 3 \\ \hline \end{array} \downarrow\downarrow\downarrow$$

quartet 4S $J=\frac{3}{2}$,
 $M_J = \frac{+3}{2}, \frac{+1}{2}, \frac{-1}{2}, \frac{-3}{2}$.

$$\left| {}^4S_{J=\frac{3}{2}}^{\frac{3}{2}} \right\rangle = \begin{array}{|c|} \hline 1\uparrow \\ \hline 2\uparrow \\ \hline 3\uparrow \\ \hline \end{array} \begin{array}{l} a \\ c \\ e \end{array}, \quad \left| {}^4S_{J=\frac{3}{2}}^{\frac{1}{2}} \right\rangle = \begin{array}{|c|} \hline 1\uparrow \\ \hline 2\uparrow \\ \hline 3\downarrow \\ \hline \end{array} \begin{array}{l} a \\ c \\ f \end{array}, \quad \left| {}^4S_{J=\frac{3}{2}}^{\frac{-1}{2}} \right\rangle = \begin{array}{|c|} \hline 1\uparrow \\ \hline 2\downarrow \\ \hline 3\downarrow \\ \hline \end{array} \begin{array}{l} a \\ d \\ f \end{array}, \quad \left| {}^4S_{J=\frac{3}{2}}^{\frac{-3}{2}} \right\rangle = \begin{array}{|c|} \hline 1\downarrow \\ \hline 2\downarrow \\ \hline 3\downarrow \\ \hline \end{array} \begin{array}{l} b \\ d \\ f \end{array}$$

$$\left| {}^4S_{J=\frac{3}{2}}^{\frac{3}{2}} \right\rangle = \begin{array}{|c|} \hline a \\ \hline c \\ \hline e \\ \hline \end{array}, \quad \left| {}^4S_{J=\frac{3}{2}}^{\frac{1}{2}} \right\rangle = \begin{array}{|c|} \hline a \\ \hline c \\ \hline f \\ \hline \end{array}, \quad \left| {}^4S_{J=\frac{3}{2}}^{\frac{-1}{2}} \right\rangle = \begin{array}{|c|} \hline a \\ \hline d \\ \hline f \\ \hline \end{array}, \quad \left| {}^4S_{J=\frac{3}{2}}^{\frac{-3}{2}} \right\rangle = \begin{array}{|c|} \hline b \\ \hline d \\ \hline f \\ \hline \end{array}$$

Slater determinant state key:

$$a=1\uparrow, b=1\downarrow, c=2\uparrow, d=2\downarrow, e=3\uparrow, f=3\downarrow$$

$(S_3)^*(U(3)) \subset U(6)$ models of p^3 electronic spin-orbit states and couplings

$[2,1]$ tableau states lowered by $L_- = \sqrt{2}(E_{21} + E_{32})$

Top-(J,M) states thru mid-level states

$\ell=1$ p -shell LS states combined to states of definite J

J=3/2 at L=0 (4S). J=5/2 at L=2 (2D)

Clebsch-Gordon coupling; J=3/2 at L=2 (2D)

J=3/2 at L=1 (2P)

J=1/2 at L=1 (2P)

Spin-orbit state assembly formula and Slater determinants

The simplest assembly

$\ell=1$ p -shell LSJ states transformed to Slater determinants from J=3/2 (4S)

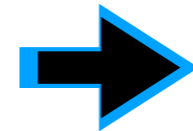

Slater functions for J=5/2 (2D)

Slater functions for J=3/2 (2D)

Slater functions for J=3/2 (2P)

Slater functions for J=1/2 (2P)

Application to spin-orbit and entanglement break-up scattering

$\ell=1$ p -shell LSJ states transformed to Slater determinants from $J=5/2$ at $L=2$

$M_J=5/2, \dots$

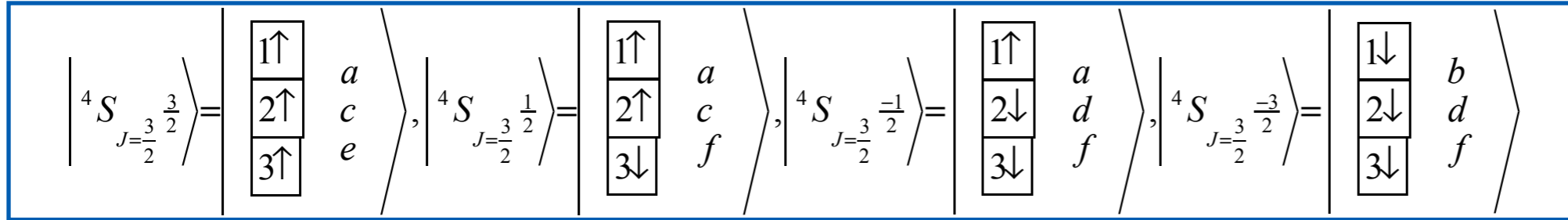

quartet 4S $J=3/2$,
 $M_J = \frac{+3}{2}, \frac{+1}{2}, \frac{-1}{2}, \frac{-3}{2}$.

$$|^2D_{J=5/2}^{M_J=5/2}\rangle = |d_{M=2}^{L=2} \chi_{1/2}\rangle \quad \text{Doublet } ^2D, J=\frac{5}{2} \quad M_J=\frac{5}{2},$$

$2 \times 1/2$	$5/2$						
	$+5/2$	$5/2$	$3/2$				
$+2$	$+1/2$	1	$+3/2$	$+3/2$			
$+2$	$-1/2$	$1/5$	$4/5$	$5/2$	$3/2$		
$+1$	$+1/2$	$4/5$	$-1/5$	$+1/2$	$+1/2$		
	$+1$	$2/5$	$3/5$	$5/2$	$3/2$		
	0	$+1/2$	$3/5$	$-2/5$	$-1/2$	$-1/2$	
		0	$-1/2$	$3/5$	$2/5$	$5/2$	$3/2$
		-1	$+1/2$	$2/5$	$-3/5$	$-3/2$	$-3/2$
			-1	$-1/2$	$4/5$	$1/5$	$5/2$
			-2	$+1/2$	$1/5$	$-4/5$	$-5/2$
				-2	$-1/2$		1

Slater determinant state key:

$$a=1\uparrow, b=1\downarrow, c=2\uparrow, d=2\downarrow, e=3\uparrow, f=3\downarrow$$

$\ell=1$ p -shell LSJ states transformed to Slater determinants from $J=5/2$ at $L=2$

$$\left| {}^4S_{J=\frac{3}{2}}^{\frac{3}{2}} \right\rangle = \begin{vmatrix} a \\ c \\ e \end{vmatrix}, \quad \left| {}^4S_{J=\frac{3}{2}}^{\frac{1}{2}} \right\rangle = \begin{vmatrix} a \\ c \\ f \end{vmatrix}, \quad \left| {}^4S_{J=\frac{3}{2}}^{-\frac{1}{2}} \right\rangle = \begin{vmatrix} a \\ d \\ f \end{vmatrix}, \quad \left| {}^4S_{J=\frac{3}{2}}^{-\frac{3}{2}} \right\rangle = \begin{vmatrix} b \\ d \\ f \end{vmatrix}$$

quartet 4S $J=\frac{3}{2}$, $M_J=5/2$
 $M_J = \frac{\pm 3}{2}, \frac{\pm 1}{2}, \frac{-1}{2}, \frac{-3}{2}$.

$$\left| {}^2D_{J=\frac{5}{2}}^{\frac{5}{2}} \right\rangle = \left| d_{M=2}^{L=2} \chi_{1/2} \right\rangle \quad \text{Doublet } {}^2D, J=\frac{5}{2} \quad M_J=\frac{5}{2},$$

$$\begin{vmatrix} 1 & 1 \\ 2 & \end{vmatrix} \begin{matrix} \uparrow \uparrow \\ \downarrow \end{matrix} \begin{matrix} \uparrow \uparrow \\ \downarrow \end{matrix} \quad \begin{matrix} \uparrow \uparrow \\ \downarrow \end{matrix} \quad (+) \sqrt{\frac{2-2}{2-1}} = 0$$

A
 $\mu_1=2, \mu_2=1$

$$\begin{vmatrix} 1 & 1 \\ 2 & \end{vmatrix} \begin{matrix} \uparrow \downarrow \\ \uparrow \end{matrix} \quad (+) \sqrt{\frac{2-1}{2-1}}$$

B
 $\mu_1=2, \mu_2=1$

$$\begin{vmatrix} 1 & 1 \\ & \end{vmatrix} \begin{matrix} \uparrow \downarrow \\ \uparrow \end{matrix} \quad (+) \sqrt{\frac{1-0}{0+2}} = (+) \sqrt{\frac{1}{2}}$$

C
 $\mu_1=1, \mu_2=1$

$2 \times 1/2$		$5/2$		$5/2$		$3/2$	
		$+5/2$		$3/2$		$+3/2$	
$+2$	$+1/2$	1		$3/2$		$+3/2$	
$+2$	$-1/2$	$1/5$	$4/5$	$5/2$	$3/2$		
$+1$	$+1/2$	$4/5$	$-1/5$	$+1/2$	$+1/2$		
		$+1$	$-1/2$	$2/5$	$3/5$	$5/2$	$3/2$
		0	$+1/2$	$3/5$	$-2/5$	$-1/2$	$-1/2$
				0	$-1/2$	$3/5$	$2/5$
				-1	$+1/2$	$2/5$	$-3/5$
						$5/2$	$3/2$
				-1	$-1/2$	$4/5$	$1/5$
				-2	$+1/2$	$1/5$	$-4/5$
						$-5/2$	
						-2	$-1/2$
						1	

Slater determinant state key:

$$a=1\uparrow, b=1\downarrow, c=2\uparrow, d=2\downarrow, e=3\uparrow, f=3\downarrow$$

$\ell=1$ p -shell LSJ states transformed to Slater determinants from $J=5/2$ at $L=2$

$$\left| {}^4S_{J=\frac{3}{2}}^{\frac{3}{2}} \right\rangle = \begin{vmatrix} a \\ c \\ e \end{vmatrix}, \quad \left| {}^4S_{J=\frac{3}{2}}^{\frac{1}{2}} \right\rangle = \begin{vmatrix} a \\ c \\ f \end{vmatrix}, \quad \left| {}^4S_{J=\frac{3}{2}}^{-\frac{1}{2}} \right\rangle = \begin{vmatrix} a \\ d \\ f \end{vmatrix}, \quad \left| {}^4S_{J=\frac{3}{2}}^{-\frac{3}{2}} \right\rangle = \begin{vmatrix} b \\ d \\ f \end{vmatrix}$$

quartet 4S $J=\frac{3}{2}$, $M_J=5/2$
 $M_J = \frac{\pm 3}{2}, \frac{\pm 1}{2}, \frac{-1}{2}, \frac{-3}{2}$.

$$\left| {}^2D_{J=\frac{5}{2}}^{\frac{5}{2}} \right\rangle = \left| d_{M=2}^{L=2} \chi_{1/2} \right\rangle \text{ Doublet } {}^2D, J=\frac{5}{2} \ M_J=\frac{5}{2},$$

$$\begin{vmatrix} 1 & 1 \\ 2 & \end{vmatrix} \begin{matrix} \uparrow \uparrow \\ \downarrow \end{matrix} \begin{matrix} \uparrow \uparrow \\ \downarrow \end{matrix} \begin{matrix} \uparrow \uparrow \\ \downarrow \end{matrix} \begin{matrix} \uparrow \uparrow \\ \downarrow \end{matrix} \begin{matrix} \uparrow \uparrow \\ \downarrow \end{matrix} \begin{matrix} \uparrow \uparrow \\ \downarrow \end{matrix} \begin{matrix} \uparrow \uparrow \\ \downarrow \end{matrix} \begin{matrix} \uparrow \uparrow \\ \downarrow \end{matrix}$$

$$\begin{matrix} \uparrow \uparrow & \uparrow \uparrow \\ 2 \downarrow & \end{matrix} \text{ (A) } (+) \sqrt{\frac{2-2}{2-1}} = 0, \quad \mu_1=2, \mu_2=1$$

$$\begin{matrix} \uparrow \uparrow & \uparrow \downarrow \\ 2 \uparrow & \end{matrix} \text{ (B) } (+) \sqrt{\frac{2-1}{2-1}}, \quad \mu_1=2, \mu_2=1$$

$$\begin{matrix} \uparrow \uparrow & \uparrow \downarrow \\ & \end{matrix} \text{ (C) } (+) \sqrt{\frac{1-0}{0+1}} = (+) \sqrt{\frac{1}{1}}, \quad \mu_1=1, \mu_2=1$$

$2 \times 1/2$	$5/2$			
$+2$	$+1/2$	1	$5/2$	$3/2$
			$3/2$	$+3/2$
$+2$	$-1/2$	$1/5$	$4/5$	$5/2$
$+1$	$+1/2$	$4/5$	$-1/5$	$+1/2$
			$+1/2$	$+1/2$
$+1$	$-1/2$	$2/5$	$3/5$	$5/2$
0	$+1/2$	$3/5$	$-2/5$	$3/2$
			$-1/2$	$-1/2$
0	$-1/2$	$3/5$	$2/5$	$5/2$
-1	$+1/2$	$2/5$	$-3/5$	$3/2$
			$-3/2$	$-3/2$
-1	$-1/2$	$4/5$	$1/5$	$5/2$
-2	$+1/2$	$1/5$	$-4/5$	$-5/2$
			-2	$-1/2$
				1

$$\begin{matrix} \uparrow \\ \downarrow \\ 2 \uparrow \end{matrix} \begin{matrix} a \\ b \\ c \end{matrix}$$

Slater determinant state key:
 $a=1 \uparrow, b=1 \downarrow, c=2 \uparrow, d=2 \downarrow, e=3 \uparrow, f=3 \downarrow$

$(S_3)^*(U(3)) \subset U(6)$ models of p^3 electronic spin-orbit states and couplings

$[2,1]$ tableau states lowered by $L_- = \sqrt{2}(E_{21} + E_{32})$

Top-(J,M) states thru mid-level states

$\ell=1$ p -shell LS states combined to states of definite J

J=3/2 at L=0 (4S). J=5/2 at L=2 (2D)

Clebsch-Gordon coupling; J=3/2 at L=2 (2D)

J=3/2 at L=1 (2P)

J=1/2 at L=1 (2P)

Spin-orbit state assembly formula and Slater determinants

The simplest assembly

$\ell=1$ p -shell LSJ states transformed to Slater determinants from J=3/2 (4S)

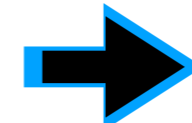
 Slater functions for J=5/2 (2D)
Slater functions for J=3/2 (2D)
Slater functions for J=3/2 (2P)
Slater functions for J=1/2 (2P)

Application to spin-orbit and entanglement break-up scattering

$\ell=1$ p -shell LSJ states transformed to Slater determinants from $J=3/2$ at $L=2$

$$\left| {}^4S_{J=\frac{3}{2}}^{\frac{3}{2}} \right\rangle = \begin{vmatrix} a \\ c \\ e \end{vmatrix}, \quad \left| {}^4S_{J=\frac{3}{2}}^{\frac{1}{2}} \right\rangle = \begin{vmatrix} a \\ c \\ f \end{vmatrix}, \quad \left| {}^4S_{J=\frac{3}{2}}^{-\frac{1}{2}} \right\rangle = \begin{vmatrix} a \\ d \\ f \end{vmatrix}, \quad \left| {}^4S_{J=\frac{3}{2}}^{-\frac{3}{2}} \right\rangle = \begin{vmatrix} b \\ d \\ f \end{vmatrix}$$

quartet 4S $J=\frac{3}{2}$, $M_J=3/2$
 $M_J = \frac{\pm 3}{2}, \frac{\pm 1}{2}, \frac{-1}{2}, \frac{-3}{2}$.

$$\left| {}^2D_{J=\frac{5}{2}}^{\frac{5}{2}} \right\rangle = \begin{vmatrix} d_{M=2}^{L=2} \chi_{1/2}^{1/2} \\ \boxed{1} \boxed{1} \\ \boxed{2} \end{vmatrix} \quad \text{Doublet } {}^2D, J=\frac{5}{2} \quad M_J=\frac{5}{2}, \quad \begin{matrix} a \\ =b \\ c \end{matrix}$$

$2 \times 1/2$		$5/2$				
$+2$	$+1/2$	$+5/2$	$5/2$	$3/2$		
		1	$+3/2$	$+3/2$		
$+2$	$-1/2$	$1/5$	$4/5$	$5/2$	$3/2$	
$+1$	$+1/2$	$4/5$	$-1/5$	$+1/2$	$+1/2$	
$+1$	$-1/2$	$2/5$	$3/5$	$5/2$	$3/2$	
0	$+1/2$	$3/5$	$-2/5$	$-1/2$	$-1/2$	
0	$-1/2$	$3/5$	$2/5$	$5/2$	$3/2$	
-1	$+1/2$	$2/5$	$-3/5$	$-3/2$	$-3/2$	
-1	$-1/2$	$4/5$	$1/5$	$5/2$		
-2	$+1/2$	$1/5$	$-4/5$	$-5/2$		
-2	$-1/2$				1	

$$\left| {}^2D_{J=\frac{5}{2}}^{\frac{3}{2}} \right\rangle = \sqrt{\frac{1}{5}} \left| d_{M=2}^{L=2} \chi_{-1/2}^{1/2} \right\rangle + \sqrt{\frac{4}{5}} \left| d_{M=1}^{L=2} \chi_{1/2}^{1/2} \right\rangle \quad \text{Doublet } {}^2D, J=\frac{5}{2} \quad M_J=\frac{3}{2}$$

$\ell=1$ p -shell LSJ states transformed to Slater determinants from $J=5/2$ at $L=2$

$$\left| {}^4S_{J=\frac{3}{2}}^{\frac{3}{2}} \right\rangle = \left| \begin{array}{c} a \\ c \\ e \end{array} \right\rangle, \quad \left| {}^4S_{J=\frac{3}{2}}^{\frac{1}{2}} \right\rangle = \left| \begin{array}{c} a \\ c \\ f \end{array} \right\rangle, \quad \left| {}^4S_{J=\frac{3}{2}}^{-\frac{1}{2}} \right\rangle = \left| \begin{array}{c} a \\ d \\ f \end{array} \right\rangle, \quad \left| {}^4S_{J=\frac{3}{2}}^{-\frac{3}{2}} \right\rangle = \left| \begin{array}{c} b \\ d \\ f \end{array} \right\rangle$$

quartet 4S $J=\frac{3}{2}$, $M_J=3/2$
 $M_J = \frac{\pm 3}{2}, \frac{\pm 1}{2}, \frac{-1}{2}, \frac{-3}{2}$.

$$\left| {}^2D_{J=\frac{5}{2}}^{\frac{5}{2}} \right\rangle = \left| d_{M=2}^{L=2} \chi_{1/2}^{1/2} \right\rangle \text{ Doublet } {}^2D, J=\frac{5}{2} M_J=\frac{5}{2}, \begin{array}{l} a \\ =b \\ c \end{array}$$

$$= \left| \begin{array}{|c|} \hline 1 \\ \hline 2 \end{array} \begin{array}{|c|} \hline 1 \\ \hline \end{array} \begin{array}{c} \uparrow\uparrow \\ \downarrow \end{array} \right\rangle$$

$2 \times 1/2$		$5/2$			
$+2$	$+1/2$	$+5/2$	1	$5/2$	$3/2$
				$+3/2$	$+3/2$
$+2$	$-1/2$	$1/5$	$4/5$	$5/2$	$3/2$
$+1$	$+1/2$	$4/5$	$-1/5$	$+1/2$	$+1/2$
$+1$	$-1/2$	$2/5$	$3/5$	$5/2$	$3/2$
0	$+1/2$	$3/5$	$-2/5$	$-1/2$	$-1/2$
0	$-1/2$	$3/5$	$2/5$	$5/2$	$3/2$
-1	$+1/2$	$2/5$	$-3/5$	$-3/2$	$-3/2$
-1	$-1/2$	$4/5$	$1/5$	$5/2$	$3/2$
-2	$+1/2$	$1/5$	$-4/5$	$-5/2$	$-5/2$
-2	$-1/2$			1	

$$\left| {}^2D_{J=\frac{5}{2}}^{\frac{3}{2}} \right\rangle = \sqrt{\frac{1}{5}} \left| d_{M=2}^{L=2} \chi_{-1/2}^{1/2} \right\rangle + \sqrt{\frac{4}{5}} \left| d_{M=1}^{L=2} \chi_{1/2}^{1/2} \right\rangle \text{ Doublet } {}^2D, J=\frac{5}{2} M_J=\frac{3}{2}$$

$$= \sqrt{\frac{1}{5}} \left| \begin{array}{|c|} \hline 1 \\ \hline 2 \end{array} \begin{array}{|c|} \hline 1 \\ \hline \end{array} \begin{array}{c} \uparrow\downarrow \\ \downarrow \end{array} \right\rangle + \sqrt{\frac{4}{5}} \left[\sqrt{\frac{1}{2}} \left| \begin{array}{|c|} \hline 1 \\ \hline 2 \end{array} \begin{array}{|c|} \hline 2 \\ \hline \end{array} \begin{array}{c} \uparrow\uparrow \\ \downarrow \end{array} \right\rangle + \sqrt{\frac{1}{2}} \left| \begin{array}{|c|} \hline 1 \\ \hline 3 \end{array} \begin{array}{|c|} \hline 1 \\ \hline \end{array} \begin{array}{c} \uparrow\uparrow \\ \downarrow \end{array} \right\rangle \right] = \sqrt{\frac{1}{5}} \left| \begin{array}{|c|} \hline 1 \\ \hline 2 \end{array} \begin{array}{|c|} \hline 1 \\ \hline \end{array} \begin{array}{c} \uparrow\downarrow \\ \downarrow \end{array} \right\rangle + \sqrt{\frac{2}{5}} \left| \begin{array}{|c|} \hline 1 \\ \hline 2 \end{array} \begin{array}{|c|} \hline 2 \\ \hline \end{array} \begin{array}{c} \uparrow\uparrow \\ \downarrow \end{array} \right\rangle + \sqrt{\frac{2}{5}} \left| \begin{array}{|c|} \hline 1 \\ \hline 3 \end{array} \begin{array}{|c|} \hline 1 \\ \hline \end{array} \begin{array}{c} \uparrow\uparrow \\ \downarrow \end{array} \right\rangle$$

$\ell=1$ p -shell LSJ states transformed to Slater determinants from $J=3/2$ at $L=2$

$$\left| {}^4S_{J=\frac{3}{2}}^{\frac{3}{2}} \right\rangle = \left| \begin{array}{c} a \\ c \\ e \end{array} \right\rangle, \left| {}^4S_{J=\frac{3}{2}}^{\frac{1}{2}} \right\rangle = \left| \begin{array}{c} a \\ c \\ f \end{array} \right\rangle, \left| {}^4S_{J=\frac{3}{2}}^{-\frac{1}{2}} \right\rangle = \left| \begin{array}{c} a \\ d \\ f \end{array} \right\rangle, \left| {}^4S_{J=\frac{3}{2}}^{-\frac{3}{2}} \right\rangle = \left| \begin{array}{c} b \\ d \\ f \end{array} \right\rangle$$

quartet 4S $J=\frac{3}{2}$, $M_J=3/2$
 $M_J = \frac{\pm 3}{2}, \frac{\pm 1}{2}, \frac{-1}{2}, \frac{-3}{2}$.

$$\left| {}^2D_{J=\frac{5}{2}}^{\frac{5}{2}} \right\rangle = \left| d_{M=2}^{L=2} \chi_{1/2}^{1/2} \right\rangle \text{ Doublet } {}^2D, J=\frac{5}{2} M_J=\frac{5}{2},$$

$$= \left| \begin{array}{cc} \boxed{1} & \boxed{1} \\ \boxed{2} & \end{array} \right\rangle \begin{array}{c} \uparrow\uparrow \\ \downarrow \end{array}$$

$2 \times 1/2$		$5/2$	$5/2$	$3/2$		
$+2$	$+1/2$	$+5/2$	1	$+3/2$	$+3/2$	
$+2$	$-1/2$	$1/5$	$4/5$	$5/2$	$3/2$	
$+1$	$+1/2$	$4/5$	$-1/5$	$+1/2$	$+1/2$	
$+1$	$-1/2$	$2/5$	$3/5$	$5/2$	$3/2$	
0	$+1/2$	$3/5$	$-2/5$	$-1/2$	$-1/2$	
0	$-1/2$	$3/5$	$2/5$	$5/2$	$3/2$	
-1	$+1/2$	$2/5$	$-3/5$	$-3/2$	$-3/2$	
-1	$-1/2$	$4/5$	$1/5$	$5/2$	$3/2$	
-2	$+1/2$	$1/5$	$-4/5$	$-5/2$	$-5/2$	
-2	$-1/2$			1		

$$\left| {}^2D_{J=\frac{5}{2}}^{\frac{3}{2}} \right\rangle = \sqrt{\frac{1}{5}} \left| d_{M=2}^{L=2} \chi_{-1/2}^{1/2} \right\rangle + \sqrt{\frac{4}{5}} \left| d_{M=1}^{L=2} \chi_{1/2}^{1/2} \right\rangle \text{ Doublet } {}^2D, J=\frac{5}{2} M_J=\frac{3}{2}$$

$$= \sqrt{\frac{1}{5}} \left| \begin{array}{cc} \boxed{1} & \boxed{1} \\ \boxed{2} & \end{array} \right\rangle \begin{array}{c} \uparrow\downarrow \\ \downarrow \end{array} + \sqrt{\frac{4}{5}} \left[\sqrt{\frac{1}{2}} \left| \begin{array}{cc} \boxed{1} & \boxed{2} \\ \boxed{2} & \end{array} \right\rangle \begin{array}{c} \uparrow\uparrow \\ \downarrow \end{array} + \sqrt{\frac{1}{2}} \left| \begin{array}{cc} \boxed{1} & \boxed{1} \\ \boxed{3} & \end{array} \right\rangle \begin{array}{c} \uparrow\uparrow \\ \downarrow \end{array} \right] = \sqrt{\frac{1}{5}} \left| \begin{array}{cc} \boxed{1} & \boxed{1} \\ \boxed{2} & \end{array} \right\rangle \begin{array}{c} \uparrow\downarrow \\ \downarrow \end{array} + \sqrt{\frac{2}{5}} \left| \begin{array}{cc} \boxed{1} & \boxed{2} \\ \boxed{2} & \end{array} \right\rangle \begin{array}{c} \uparrow\uparrow \\ \downarrow \end{array} + \sqrt{\frac{2}{5}} \left| \begin{array}{cc} \boxed{1} & \boxed{1} \\ \boxed{3} & \end{array} \right\rangle \begin{array}{c} \uparrow\uparrow \\ \downarrow \end{array}$$

$$\left| {}^2D_{J=\frac{3}{2}}^{\frac{3}{2}} \right\rangle = \sqrt{\frac{4}{5}} \left| d_{M=2}^{L=2} \chi_{-1/2}^{1/2} \right\rangle - \sqrt{\frac{1}{5}} \left| d_{M=1}^{L=2} \chi_{+1/2}^{1/2} \right\rangle \text{ Doublet } {}^2D, J=\frac{3}{2} M_J=\frac{3}{2}$$

$\ell=1$ p -shell LSJ states transformed to Slater determinants from $J=3/2$ at $L=2$

$$\left| {}^4S_{J=\frac{3}{2}}^{\frac{3}{2}} \right\rangle = \left| \begin{array}{c} a \\ c \\ e \end{array} \right\rangle, \left| {}^4S_{J=\frac{3}{2}}^{\frac{1}{2}} \right\rangle = \left| \begin{array}{c} a \\ c \\ f \end{array} \right\rangle, \left| {}^4S_{J=\frac{3}{2}}^{-\frac{1}{2}} \right\rangle = \left| \begin{array}{c} a \\ d \\ f \end{array} \right\rangle, \left| {}^4S_{J=\frac{3}{2}}^{-\frac{3}{2}} \right\rangle = \left| \begin{array}{c} b \\ d \\ f \end{array} \right\rangle$$

quartet 4S $J=\frac{3}{2}$, $M_J=3/2$
 $M_J = \frac{\pm 3}{2}, \frac{\pm 1}{2}, \frac{-1}{2}, \frac{-3}{2}$.

$$\left| {}^2D_{J=\frac{5}{2}}^{\frac{5}{2}} \right\rangle = \left| d_{M=2}^{L=2} \chi_{1/2}^{1/2} \right\rangle \text{ Doublet } {}^2D, J=\frac{5}{2} M_J=\frac{5}{2},$$

$$= \left| \begin{array}{cc} \boxed{1} & \boxed{1} \\ \boxed{2} & \end{array} \uparrow\uparrow \right\rangle$$

$2 \times 1/2$		$5/2$	$5/2$	$3/2$			
$+2$	$+1/2$	$+5/2$	1	$+3/2$	$+3/2$		
$+2$	$-1/2$	$1/5$	$4/5$	$5/2$	$3/2$		
$+1$	$+1/2$	$4/5$	$-1/5$	$+1/2$	$+1/2$		
$+1$	$-1/2$	$2/5$	$3/5$	$5/2$	$3/2$		
0	$+1/2$	$3/5$	$-2/5$	$-1/2$	$-1/2$		
0	$-1/2$	$3/5$	$2/5$	$5/2$	$3/2$		
-1	$+1/2$	$2/5$	$-3/5$	$-3/2$	$-3/2$		
-1	$-1/2$	$4/5$	$1/5$	$5/2$	$3/2$		
-2	$+1/2$	$1/5$	$-4/5$	$-5/2$	$-5/2$		
-2	$-1/2$					1	

$$\left| {}^2D_{J=\frac{5}{2}}^{\frac{3}{2}} \right\rangle = \sqrt{\frac{1}{5}} \left| d_{M=2}^{L=2} \chi_{-1/2}^{1/2} \right\rangle + \sqrt{\frac{4}{5}} \left| d_{M=1}^{L=2} \chi_{1/2}^{1/2} \right\rangle \text{ Doublet } {}^2D, J=\frac{5}{2} M_J=\frac{3}{2}$$

$$= \sqrt{\frac{1}{5}} \left| \begin{array}{cc} \boxed{1} & \boxed{1} \\ \boxed{2} & \end{array} \uparrow\downarrow \right\rangle + \sqrt{\frac{4}{5}} \left[\sqrt{\frac{1}{2}} \left| \begin{array}{cc} \boxed{1} & \boxed{2} \\ \boxed{2} & \end{array} \uparrow\uparrow \right\rangle + \sqrt{\frac{1}{2}} \left| \begin{array}{cc} \boxed{1} & \boxed{1} \\ \boxed{3} & \end{array} \uparrow\uparrow \right\rangle \right]$$

$$= \sqrt{\frac{1}{5}} \left| \begin{array}{cc} \boxed{1} & \boxed{1} \\ \boxed{2} & \end{array} \uparrow\downarrow \right\rangle + \sqrt{\frac{2}{5}} \left| \begin{array}{cc} \boxed{1} & \boxed{2} \\ \boxed{2} & \end{array} \uparrow\uparrow \right\rangle + \sqrt{\frac{2}{5}} \left| \begin{array}{cc} \boxed{1} & \boxed{1} \\ \boxed{3} & \end{array} \uparrow\uparrow \right\rangle$$

$$\left| {}^2D_{J=\frac{3}{2}}^{\frac{3}{2}} \right\rangle = \sqrt{\frac{4}{5}} \left| d_{M=2}^{L=2} \chi_{-1/2}^{1/2} \right\rangle - \sqrt{\frac{1}{5}} \left| d_{M=1}^{L=2} \chi_{+1/2}^{1/2} \right\rangle \text{ Doublet } {}^2D, J=\frac{3}{2} M_J=\frac{3}{2}$$

$$= \sqrt{\frac{4}{5}} \left| \begin{array}{cc} \boxed{1} & \boxed{1} \\ \boxed{2} & \end{array} \uparrow\downarrow \right\rangle - \sqrt{\frac{1}{5}} \left[\sqrt{\frac{1}{2}} \left| \begin{array}{cc} \boxed{1} & \boxed{2} \\ \boxed{2} & \end{array} \uparrow\uparrow \right\rangle + \sqrt{\frac{1}{2}} \left| \begin{array}{cc} \boxed{1} & \boxed{1} \\ \boxed{3} & \end{array} \uparrow\uparrow \right\rangle \right]$$

$$= \sqrt{\frac{4}{5}} \left| \begin{array}{cc} \boxed{1} & \boxed{1} \\ \boxed{2} & \end{array} \uparrow\downarrow \right\rangle - \sqrt{\frac{1}{10}} \left| \begin{array}{cc} \boxed{1} & \boxed{2} \\ \boxed{2} & \end{array} \uparrow\uparrow \right\rangle - \sqrt{\frac{1}{10}} \left| \begin{array}{cc} \boxed{1} & \boxed{1} \\ \boxed{3} & \end{array} \uparrow\uparrow \right\rangle$$

$(S_3)^*(U(3)) \subset U(6)$ models of p^3 electronic spin-orbit states and couplings

$[2,1]$ tableau states lowered by $L_- = \sqrt{2}(E_{21} + E_{32})$

Top-(J,M) states thru mid-level states

$\ell=1$ p -shell LS states combined to states of definite J

J=3/2 at L=0 (4S). J=5/2 at L=2 (2D)

Clebsch-Gordon coupling; J=3/2 at L=2 (2D)

J=3/2 at L=1 (2P)

J=1/2 at L=1 (2P)

Spin-orbit state assembly formula and Slater determinants

The simplest assembly

$\ell=1$ p -shell LSJ states transformed to Slater determinants from J=3/2 (4S)

Slater functions for J=5/2 (2D)

Slater functions for J=3/2 (2D)

 Slater functions for J=3/2 (2P)

Slater functions for J=1/2 (2P)

Application to spin-orbit and entanglement break-up scattering

$\ell=1$ p -shell LSJ states transformed to Slater determinants from $J=3/2$ at $L=1$

$$\left| {}^2P_{J=\frac{3}{2}}^{\frac{3}{2}} \right\rangle = \left| p_{M=1}^{L=1} \chi_{+1/2} \right\rangle$$

Doublet 2P , $J=\frac{3}{2}$ $M_J=\frac{3}{2}$

$M_J=3/2$

$1 \times 1/2$		$3/2$				
		$+3/2$	$3/2$	$1/2$		
$+1$	$+1/2$	1	$+1/2$	$+1/2$		
$+1$	$-1/2$	$1/3$	$2/3$	$3/2$	$1/2$	
0	$+1/2$	$2/3$	$-1/3$	$-1/2$	$-1/2$	
		0	$-1/2$	$2/3$	$1/3$	$3/2$
		-1	$+1/2$	$1/3$	$-2/3$	$-3/2$
				-1	$-1/2$	1

$\ell=1$ p -shell LSJ states transformed to Slater determinants from $J=3/2$ at $L=1$

$M_J=3/2$

$$\left| {}^2P_{J=\frac{3}{2}}^{\frac{3}{2}} \right\rangle = \left| p_{M=1}^{L=1} \chi_{+1/2} \right\rangle \quad \text{Doublet } {}^2P, J=\frac{3}{2} \quad M_J=\frac{3}{2}$$

$$= \left[\sqrt{\frac{1}{2}} \begin{array}{|c|c|} \hline 1 & 2 \\ \hline 2 & \\ \hline \end{array} \begin{array}{c} \uparrow\uparrow \\ \downarrow \end{array} - \sqrt{\frac{1}{2}} \begin{array}{|c|c|} \hline 1 & 1 \\ \hline 3 & \\ \hline \end{array} \begin{array}{c} \uparrow\uparrow \\ \downarrow \end{array} \right]$$

$1 \times 1/2$		$3/2$				
		$+3/2$	$3/2$	$1/2$		
$+1$	$+1/2$	1	$+1/2$	$+1/2$		
$+1$	$-1/2$	$1/3$	$2/3$	$3/2$	$1/2$	
0	$+1/2$	$2/3$	$-1/3$	$-1/2$	$-1/2$	
		0	$-1/2$	$2/3$	$1/3$	$3/2$
		-1	$+1/2$	$1/3$	$-2/3$	$-3/2$
				-1	$-1/2$	1

$\ell=1$ p -shell LSJ states transformed to Slater determinants from $J=3/2$ at $L=1$

$M_J=1/2$

$$\left| {}^2P_{J=\frac{3}{2}}^{\frac{3}{2}} \right\rangle = \left| p_{M=1}^{L=1} \chi_{+1/2} \right\rangle \quad \text{Doublet } {}^2P, J=\frac{3}{2} \quad M_J=\frac{3}{2}$$

$$= \left[\sqrt{\frac{1}{2}} \begin{array}{|c|c|} \hline 1 & 2 \\ \hline 2 & \\ \hline \end{array} \uparrow\uparrow \quad -\sqrt{\frac{1}{2}} \begin{array}{|c|c|} \hline 1 & 1 \\ \hline 3 & \\ \hline \end{array} \uparrow\uparrow \right]$$

$$\left| {}^2P_{J=\frac{3}{2}}^{\frac{1}{2}} \right\rangle = \sqrt{\frac{1}{3}} \left| p_{M=1}^{L=1} \chi_{-1/2} \right\rangle + \sqrt{\frac{2}{3}} \left| p_{M=0}^{L=1} \chi_{+1/2} \right\rangle \quad \text{Doublet } {}^2P, J=\frac{3}{2} \quad M_J=\frac{1}{2}$$

$1 \times 1/2$		$3/2$				
		$+3/2$	$3/2$	$1/2$		
$+1$	$+1/2$	1	$+1/2$	$+1/2$		
			$+1$	$-1/2$	$1/3$	$2/3$
			0	$+1/2$	$2/3$	$-1/3$
					$-1/2$	$-1/2$
					0	$-1/2$
					-1	$+1/2$
						$2/3$
						$1/3$
						$-2/3$
						$3/2$
						$-3/2$
						1

$\ell=1$ p -shell LSJ states transformed to Slater determinants from $J=3/2$ at $L=1$

$M_J=1/2$

$$\left| {}^2P_{J=\frac{3}{2}}^{\frac{3}{2}} \right\rangle = \left| p_{M=1}^{L=1} \chi_{+1/2} \right\rangle \quad \text{Doublet } {}^2P, J=\frac{3}{2} \quad M_J=\frac{3}{2}$$

$$= \left[\sqrt{\frac{1}{2}} \begin{array}{|c|c|} \hline 1 & 2 \\ \hline 2 & \\ \hline \end{array} \uparrow\uparrow \downarrow - \sqrt{\frac{1}{2}} \begin{array}{|c|c|} \hline 1 & 1 \\ \hline 3 & \\ \hline \end{array} \uparrow\uparrow \downarrow \right]$$

$1 \times 1/2$		$3/2$				
		$+3/2$	$3/2$	$1/2$		
$+1$	$+1/2$	1	$+1/2$	$+1/2$		
			$+1 - 1/2$	$1/3$	$2/3$	$3/2$
			$0 + 1/2$	$2/3$	$-1/3$	$-1/2$
						$3/2$
			$0 - 1/2$	$2/3$	$1/3$	$3/2$
			$-1 + 1/2$	$1/3$	$-2/3$	$-3/2$
						1
						$-1 - 1/2$

$$\left| {}^2P_{J=\frac{3}{2}}^{\frac{1}{2}} \right\rangle = \sqrt{\frac{1}{3}} \left| p_{M=1}^{L=1} \chi_{-1/2} \right\rangle + \sqrt{\frac{2}{3}} \left| p_{M=0}^{L=1} \chi_{+1/2} \right\rangle \quad \text{Doublet } {}^2P, J=\frac{3}{2} \quad M_J=\frac{1}{2}$$

$$= \sqrt{\frac{1}{3}} \left[\sqrt{\frac{1}{2}} \begin{array}{|c|c|} \hline 1 & 2 \\ \hline 2 & \\ \hline \end{array} \uparrow\downarrow \downarrow - \sqrt{\frac{1}{2}} \begin{array}{|c|c|} \hline 1 & 1 \\ \hline 3 & \\ \hline \end{array} \uparrow\downarrow \downarrow \right] + \sqrt{\frac{2}{3}} \left[\frac{-1}{2} \begin{array}{|c|c|} \hline 1 & 2 \\ \hline 3 & \\ \hline \end{array} \uparrow\uparrow \downarrow + \frac{\sqrt{3}}{2} \begin{array}{|c|c|} \hline 1 & 3 \\ \hline 2 & \\ \hline \end{array} \uparrow\uparrow \downarrow \right]$$

$\ell=1$ p -shell LSJ states transformed to Slater determinants from $J=3/2$ at $L=1$

$M_J=1/2$

$$\left| {}^2P_{J=\frac{3}{2}}^{\frac{3}{2}} \right\rangle = \left| p_{M=1}^{L=1} \chi_{+1/2}^{1/2} \right\rangle \quad \text{Doublet } {}^2P, J=\frac{3}{2} \quad M_J=\frac{3}{2}$$

$$= \left[\sqrt{\frac{1}{2}} \begin{array}{|c|c|} \hline 1 & 2 \\ \hline 2 & \\ \hline \end{array} \uparrow\uparrow \downarrow - \sqrt{\frac{1}{2}} \begin{array}{|c|c|} \hline 1 & 1 \\ \hline 3 & \\ \hline \end{array} \uparrow\uparrow \downarrow \right]$$

		$1 \times 1/2$	$3/2$				
		$+1 \quad +1/2$	$+3/2$	$3/2$	$1/2$		
			1	$+1/2$	$+1/2$		
		$+1 \quad -1/2$		$1/3$	$2/3$	$3/2$	$1/2$
		$0 \quad +1/2$		$2/3$	$-1/3$	$-1/2$	$-1/2$
				$0 \quad -1/2$	$2/3$	$1/3$	$3/2$
				$-1 \quad +1/2$	$1/3$	$-2/3$	$-3/2$
						$-1 \quad -1/2$	1

$$\left| {}^2P_{J=\frac{3}{2}}^{\frac{1}{2}} \right\rangle = \sqrt{\frac{1}{3}} \left| p_{M=1}^{L=1} \chi_{-1/2}^{1/2} \right\rangle + \sqrt{\frac{2}{3}} \left| p_{M=0}^{L=1} \chi_{+1/2}^{1/2} \right\rangle \quad \text{Doublet } {}^2P, J=\frac{3}{2} \quad M_J=\frac{1}{2}$$

$$= \sqrt{\frac{1}{3}} \left[\sqrt{\frac{1}{2}} \begin{array}{|c|c|} \hline 1 & 2 \\ \hline 2 & \\ \hline \end{array} \uparrow\downarrow \downarrow - \sqrt{\frac{1}{2}} \begin{array}{|c|c|} \hline 1 & 1 \\ \hline 3 & \\ \hline \end{array} \uparrow\downarrow \downarrow \right] + \sqrt{\frac{2}{3}} \left[\begin{array}{|c|c|} \hline -1 & 2 \\ \hline 3 & \\ \hline \end{array} \uparrow\uparrow \downarrow + \frac{\sqrt{3}}{2} \begin{array}{|c|c|} \hline 1 & 3 \\ \hline 2 & \\ \hline \end{array} \uparrow\uparrow \downarrow \right]$$

$$= \sqrt{\frac{1}{6}} \begin{array}{|c|c|} \hline 1 & 2 \\ \hline 2 & \\ \hline \end{array} \uparrow\downarrow \downarrow - \sqrt{\frac{1}{6}} \begin{array}{|c|c|} \hline 1 & 1 \\ \hline 3 & \\ \hline \end{array} \uparrow\downarrow \downarrow - \sqrt{\frac{1}{6}} \begin{array}{|c|c|} \hline 1 & 2 \\ \hline 3 & \\ \hline \end{array} \uparrow\uparrow \downarrow + \frac{1}{\sqrt{2}} \begin{array}{|c|c|} \hline 1 & 3 \\ \hline 2 & \\ \hline \end{array} \uparrow\uparrow \downarrow$$

$(S_3)^*(U(3)) \subset U(6)$ models of p^3 electronic spin-orbit states and couplings

$[2,1]$ tableau states lowered by $L_- = \sqrt{2}(E_{21} + E_{32})$

Top-(J,M) states thru mid-level states

$\ell=1$ p -shell LS states combined to states of definite J

J=3/2 at L=0 (4S). J=5/2 at L=2 (2D)

Clebsch-Gordon coupling; J=3/2 at L=2 (2D)

J=3/2 at L=1 (2P)

J=1/2 at L=1 (2P)

Spin-orbit state assembly formula and Slater determinants

The simplest assembly

$\ell=1$ p -shell LSJ states transformed to Slater determinants from J=3/2 (4S)

Slater functions for J=5/2 (2D)

Slater functions for J=3/2 (2D)

Slater functions for J=3/2 (2P)

 Slater functions for J=1/2 (2P)

Application to spin-orbit and entanglement break-up scattering

$\ell=1$ p -shell LSJ states transformed to Slater determinants from $J=1/2$ at $L=1$

$M_J=1/2$

$$\left| {}^2P_{J=\frac{3}{2}}^{\frac{3}{2}} \right\rangle = \left| p_{M=1}^{L=1} \chi_{+1/2}^{1/2} \right\rangle \quad \text{Doublet } {}^2P, J=\frac{3}{2} \quad M_J=\frac{3}{2}$$

$$= \left[\sqrt{\frac{1}{2}} \begin{array}{|c|c|} \hline 1 & 2 \\ \hline 2 & \\ \hline \end{array} \uparrow\uparrow \downarrow - \sqrt{\frac{1}{2}} \begin{array}{|c|c|} \hline 1 & 1 \\ \hline 3 & \\ \hline \end{array} \uparrow\uparrow \downarrow \right]$$

$1 \times 1/2$	$3/2$	$3/2$	$1/2$		
$+1 \quad +1/2$	$+3/2$	$1 \quad +1/2$	$+1/2$		
$+1 \quad -1/2$	$1/3$	$2/3$	$3/2 \quad 1/2$		
$0 \quad +1/2$	$2/3 \quad -1/3$	$-1/2 \quad -1/2$			
	$0 \quad -1/2$	$2/3 \quad 1/3$	$3/2$		
	$-1 \quad +1/2$	$1/3 \quad -2/3$	$-3/2$		
		$-1 \quad -1/2$	1		

$$\left| {}^2P_{J=\frac{3}{2}}^{\frac{1}{2}} \right\rangle = \sqrt{\frac{1}{3}} \left| p_{M=1}^{L=1} \chi_{-1/2}^{1/2} \right\rangle + \sqrt{\frac{2}{3}} \left| p_{M=0}^{L=1} \chi_{+1/2}^{1/2} \right\rangle \quad \text{Doublet } {}^2P, J=\frac{3}{2} \quad M_J=\frac{1}{2}$$

$$= \sqrt{\frac{1}{3}} \left[\sqrt{\frac{1}{2}} \begin{array}{|c|c|} \hline 1 & 2 \\ \hline 2 & \\ \hline \end{array} \uparrow\downarrow \downarrow - \sqrt{\frac{1}{2}} \begin{array}{|c|c|} \hline 1 & 1 \\ \hline 3 & \\ \hline \end{array} \uparrow\downarrow \downarrow \right] + \sqrt{\frac{2}{3}} \left[\begin{array}{|c|c|} \hline -1 & 2 \\ \hline 3 & \\ \hline \end{array} \uparrow\uparrow \downarrow + \frac{\sqrt{3}}{2} \begin{array}{|c|c|} \hline 1 & 3 \\ \hline 2 & \\ \hline \end{array} \uparrow\uparrow \downarrow \right]$$

$$= \sqrt{\frac{1}{6}} \begin{array}{|c|c|} \hline 1 & 2 \\ \hline 2 & \\ \hline \end{array} \uparrow\downarrow \downarrow - \sqrt{\frac{1}{6}} \begin{array}{|c|c|} \hline 1 & 1 \\ \hline 3 & \\ \hline \end{array} \uparrow\downarrow \downarrow - \sqrt{\frac{1}{6}} \begin{array}{|c|c|} \hline 1 & 2 \\ \hline 3 & \\ \hline \end{array} \uparrow\uparrow \downarrow + \frac{1}{\sqrt{2}} \begin{array}{|c|c|} \hline 1 & 3 \\ \hline 2 & \\ \hline \end{array} \uparrow\uparrow \downarrow$$

$$\left| {}^2P_{J=\frac{1}{2}}^{\frac{1}{2}} \right\rangle = \sqrt{\frac{2}{3}} \left| p_{M=1}^{L=1} \chi_{-1/2}^{1/2} \right\rangle - \sqrt{\frac{1}{3}} \left| p_{M=0}^{L=1} \chi_{+1/2}^{1/2} \right\rangle \quad \text{Doublet } {}^2P, J=\frac{1}{2} \quad M_J=\frac{1}{2}$$

ℓ=1 p-shell LSJ states transformed to Slater determinants from J=1/2 at L=1

$M_J=1/2$

$$\left| {}^2P_{J=\frac{3}{2}}^{\frac{3}{2}} \right\rangle = \left| p_{M=1}^{L=1} \chi_{+1/2}^{1/2} \right\rangle \quad \text{Doublet } {}^2P, J=\frac{3}{2} \quad M_J=\frac{3}{2}$$

$$= \left[\left[\sqrt{\frac{1}{2}} \begin{array}{|c|c|} \hline 1 & 2 \\ \hline 2 & \\ \hline \end{array} \uparrow\uparrow \quad -\sqrt{\frac{1}{2}} \begin{array}{|c|c|} \hline 1 & 1 \\ \hline 3 & \\ \hline \end{array} \uparrow\uparrow \right] \right]$$

$1 \times 1/2$		$3/2$				
$+1 \quad +1/2$		$+3/2$	1	$+1/2$	$+1/2$	
$+1$	$-1/2$	$1/3$	$2/3$	$3/2$	$1/2$	
0	$+1/2$	$2/3$	$-1/3$	$-1/2$	$-1/2$	
0	$-1/2$	$2/3$	$1/3$	$3/2$	$1/2$	
-1	$+1/2$	$1/3$	$-2/3$	$-3/2$	$-3/2$	
-1	$-1/2$			1		

$$\left| {}^2P_{J=\frac{3}{2}}^{\frac{1}{2}} \right\rangle = \sqrt{\frac{1}{3}} \left| p_{M=1}^{L=1} \chi_{-1/2}^{1/2} \right\rangle + \sqrt{\frac{2}{3}} \left| p_{M=0}^{L=1} \chi_{+1/2}^{1/2} \right\rangle \quad \text{Doublet } {}^2P, J=\frac{3}{2} \quad M_J=\frac{1}{2}$$

$$= \sqrt{\frac{1}{3}} \left[\left[\sqrt{\frac{1}{2}} \begin{array}{|c|c|} \hline 1 & 2 \\ \hline 2 & \\ \hline \end{array} \uparrow\downarrow \quad -\sqrt{\frac{1}{2}} \begin{array}{|c|c|} \hline 1 & 1 \\ \hline 3 & \\ \hline \end{array} \uparrow\downarrow \right] \right] + \sqrt{\frac{2}{3}} \left[\left[\frac{-1}{2} \begin{array}{|c|c|} \hline 1 & 2 \\ \hline 3 & \\ \hline \end{array} \uparrow\uparrow \quad + \frac{\sqrt{3}}{2} \begin{array}{|c|c|} \hline 1 & 3 \\ \hline 2 & \\ \hline \end{array} \uparrow\uparrow \right] \right]$$

$$= \sqrt{\frac{1}{6}} \begin{array}{|c|c|} \hline 1 & 2 \\ \hline 2 & \\ \hline \end{array} \uparrow\downarrow \quad -\sqrt{\frac{1}{6}} \begin{array}{|c|c|} \hline 1 & 1 \\ \hline 3 & \\ \hline \end{array} \uparrow\downarrow \quad -\sqrt{\frac{1}{6}} \begin{array}{|c|c|} \hline 1 & 2 \\ \hline 3 & \\ \hline \end{array} \uparrow\uparrow \quad + \frac{1}{\sqrt{2}} \begin{array}{|c|c|} \hline 1 & 3 \\ \hline 2 & \\ \hline \end{array} \uparrow\uparrow$$

$$\left| {}^2P_{J=\frac{1}{2}}^{\frac{1}{2}} \right\rangle = \sqrt{\frac{2}{3}} \left| p_{M=1}^{L=1} \chi_{-1/2}^{1/2} \right\rangle - \sqrt{\frac{1}{3}} \left| p_{M=0}^{L=1} \chi_{+1/2}^{1/2} \right\rangle \quad \text{Doublet } {}^2P, J=\frac{1}{2} \quad M_J=\frac{1}{2}$$

$$= \sqrt{\frac{2}{3}} \left[\left[\sqrt{\frac{1}{2}} \begin{array}{|c|c|} \hline 1 & 2 \\ \hline 2 & \\ \hline \end{array} \uparrow\downarrow \quad -\sqrt{\frac{1}{2}} \begin{array}{|c|c|} \hline 1 & 1 \\ \hline 3 & \\ \hline \end{array} \uparrow\downarrow \right] \right] - \sqrt{\frac{1}{3}} \left[\left[\frac{-1}{2} \begin{array}{|c|c|} \hline 1 & 2 \\ \hline 3 & \\ \hline \end{array} \uparrow\uparrow \quad + \frac{\sqrt{3}}{2} \begin{array}{|c|c|} \hline 1 & 3 \\ \hline 2 & \\ \hline \end{array} \uparrow\uparrow \right] \right]$$

ℓ=1 p-shell LSJ states transformed to Slater determinants from J=1/2 at L=1

M_J=1/2

$$\left| {}^2P_{J=\frac{3}{2}}^{\frac{3}{2}} \right\rangle = \left| p_{M=1}^{L=1} \chi_{+1/2} \right\rangle \quad \text{Doublet } {}^2P, J=\frac{3}{2} \quad M_J=\frac{3}{2}$$

$$= \left[\left[\sqrt{\frac{1}{2}} \begin{array}{|c|c|} \hline 1 & 2 \\ \hline 2 & \\ \hline \end{array} \uparrow\uparrow \quad -\sqrt{\frac{1}{2}} \begin{array}{|c|c|} \hline 1 & 1 \\ \hline 3 & \\ \hline \end{array} \uparrow\uparrow \right] \right]$$

1 × 1/2	3/2	3/2	1/2		
+1 +1/2	+3/2	1 +1/2	+1/2		
+1 -1/2	0 +1/2	1/3 2/3	2/3 -1/3	3/2 1/2	-1/2 -1/2
		0 -1/2	-1 +1/2	2/3 1/3	3/2
				1/3 -2/3	-3/2
					-1 -1/2
					1

$$\left| {}^2P_{J=\frac{3}{2}}^{\frac{1}{2}} \right\rangle = \sqrt{\frac{1}{3}} \left| p_{M=1}^{L=1} \chi_{-1/2} \right\rangle + \sqrt{\frac{2}{3}} \left| p_{M=0}^{L=1} \chi_{+1/2} \right\rangle \quad \text{Doublet } {}^2P, J=\frac{3}{2} \quad M_J=\frac{1}{2}$$

$$= \sqrt{\frac{1}{3}} \left[\left[\sqrt{\frac{1}{2}} \begin{array}{|c|c|} \hline 1 & 2 \\ \hline 2 & \\ \hline \end{array} \uparrow\downarrow \quad -\sqrt{\frac{1}{2}} \begin{array}{|c|c|} \hline 1 & 1 \\ \hline 3 & \\ \hline \end{array} \uparrow\downarrow \right] \right] + \sqrt{\frac{2}{3}} \left[\left[\begin{array}{|c|c|} \hline -\frac{1}{2} & 1 & 2 \\ \hline 3 & \\ \hline \end{array} \uparrow\uparrow \quad + \frac{\sqrt{3}}{2} \begin{array}{|c|c|} \hline 1 & 3 \\ \hline 2 & \\ \hline \end{array} \uparrow\uparrow \right] \right]$$

$$= \sqrt{\frac{1}{6}} \begin{array}{|c|c|} \hline 1 & 2 \\ \hline 2 & \\ \hline \end{array} \uparrow\downarrow \quad -\sqrt{\frac{1}{6}} \begin{array}{|c|c|} \hline 1 & 1 \\ \hline 3 & \\ \hline \end{array} \uparrow\downarrow \quad -\sqrt{\frac{1}{6}} \begin{array}{|c|c|} \hline 1 & 2 \\ \hline 3 & \\ \hline \end{array} \uparrow\uparrow \quad + \frac{1}{\sqrt{2}} \begin{array}{|c|c|} \hline 1 & 3 \\ \hline 2 & \\ \hline \end{array} \uparrow\uparrow$$

$$\left| {}^2P_{J=\frac{1}{2}}^{\frac{1}{2}} \right\rangle = \sqrt{\frac{2}{3}} \left| p_{M=1}^{L=1} \chi_{-1/2} \right\rangle - \sqrt{\frac{1}{3}} \left| p_{M=0}^{L=1} \chi_{+1/2} \right\rangle \quad \text{Doublet } {}^2P, J=\frac{1}{2} \quad M_J=\frac{1}{2}$$

$$= \sqrt{\frac{2}{3}} \left[\left[\sqrt{\frac{1}{2}} \begin{array}{|c|c|} \hline 1 & 2 \\ \hline 2 & \\ \hline \end{array} \uparrow\downarrow \quad -\sqrt{\frac{1}{2}} \begin{array}{|c|c|} \hline 1 & 1 \\ \hline 3 & \\ \hline \end{array} \uparrow\downarrow \right] \right] - \sqrt{\frac{1}{3}} \left[\left[\begin{array}{|c|c|} \hline -\frac{1}{2} & 1 & 2 \\ \hline 3 & \\ \hline \end{array} \uparrow\uparrow \quad + \frac{\sqrt{3}}{2} \begin{array}{|c|c|} \hline 1 & 3 \\ \hline 2 & \\ \hline \end{array} \uparrow\uparrow \right] \right]$$

$$= \sqrt{\frac{1}{3}} \begin{array}{|c|c|} \hline 1 & 2 \\ \hline 2 & \\ \hline \end{array} \uparrow\downarrow \quad -\sqrt{\frac{1}{3}} \begin{array}{|c|c|} \hline 1 & 1 \\ \hline 3 & \\ \hline \end{array} \uparrow\downarrow \quad + \sqrt{\frac{1}{12}} \begin{array}{|c|c|} \hline 1 & 2 \\ \hline 3 & \\ \hline \end{array} \uparrow\uparrow \quad - \frac{1}{2} \begin{array}{|c|c|} \hline 1 & 3 \\ \hline 2 & \\ \hline \end{array} \uparrow\uparrow$$

Marrying spin $s=1/2$ and orbital $\ell=1$ together: $U(3) \times U(2)$

A state satisfying Pauli-antisymmetry (Exclusion principle) can be simply represented by putting an orbital tableaux next to a conjugate spin tableaux. (Rows flipped with columns)

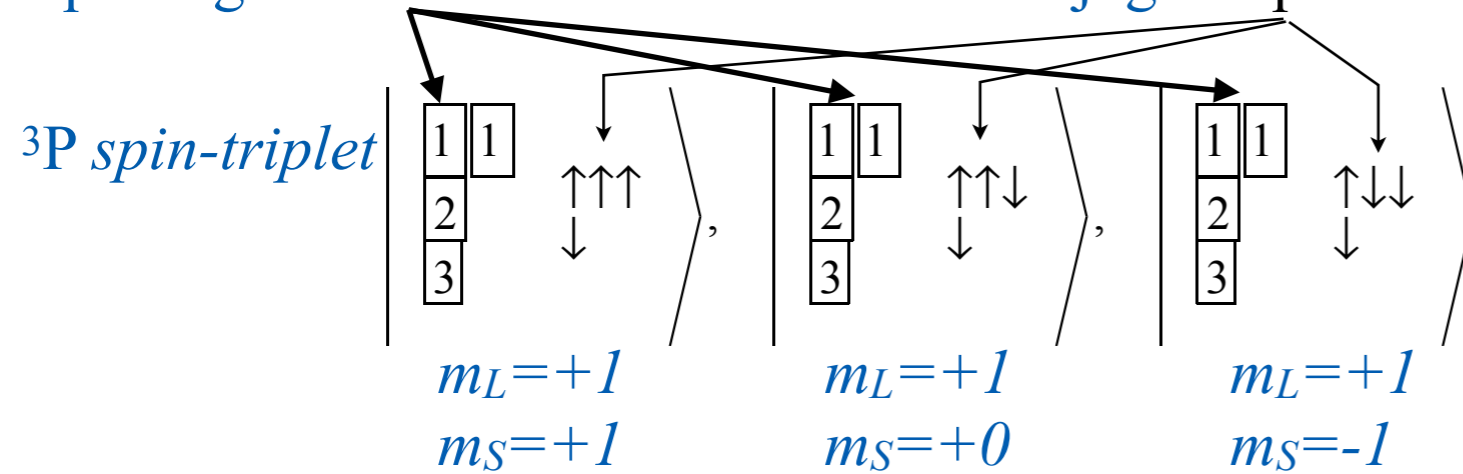

$U(3)$: $m_\ell = +1$: $|1\rangle$, $m_\ell = 0$: $|2\rangle$, $m_\ell = -1$: $|3\rangle$

$U(2)$: $m_s = +1/2$: $|\uparrow\rangle$, $m_s = -1/2$: $|\downarrow\rangle$

Marrying spin $s=1/2$ and orbital $\ell=1$ together: $U(3)\times U(2)$

A state satisfying Pauli-antisymmetry (Exclusion principle) can be simply represented by putting an orbital tableaux next to a conjugate spin tableaux. (Rows flipped with columns)

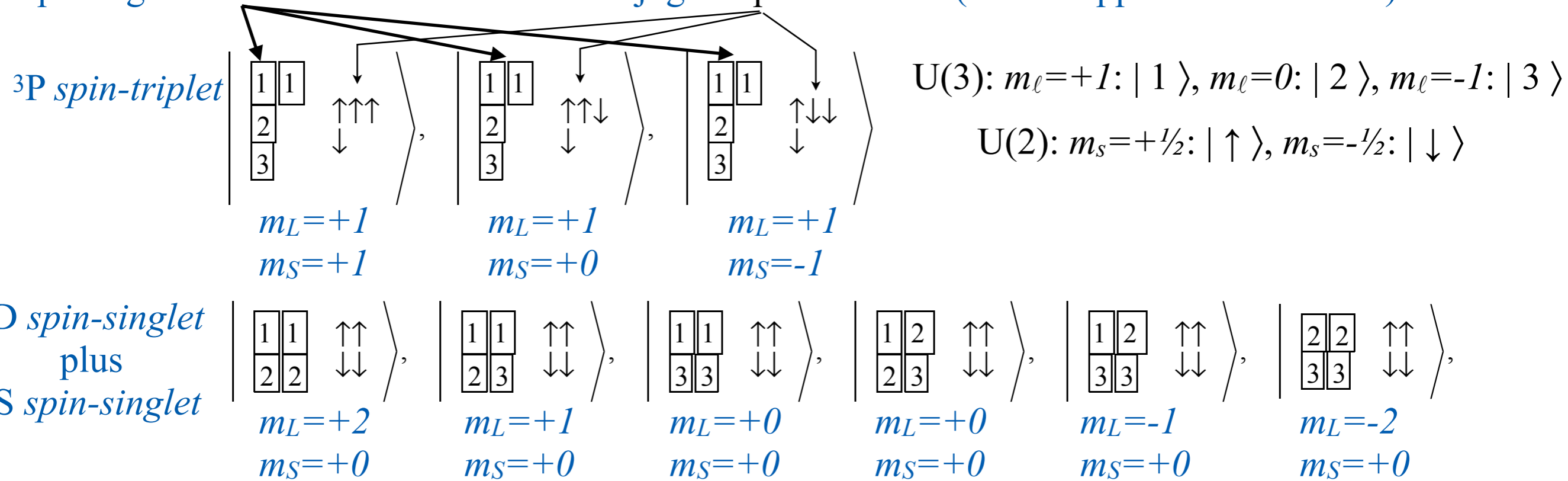

Marrying spin $s=1/2$ and orbital $\ell=1$ together: $U(3)\times U(2)$

A state satisfying Pauli-antisymmetry (Exclusion principle) can be simply represented by putting an orbital tableaux next to a conjugate spin tableaux. (Rows flipped with columns)

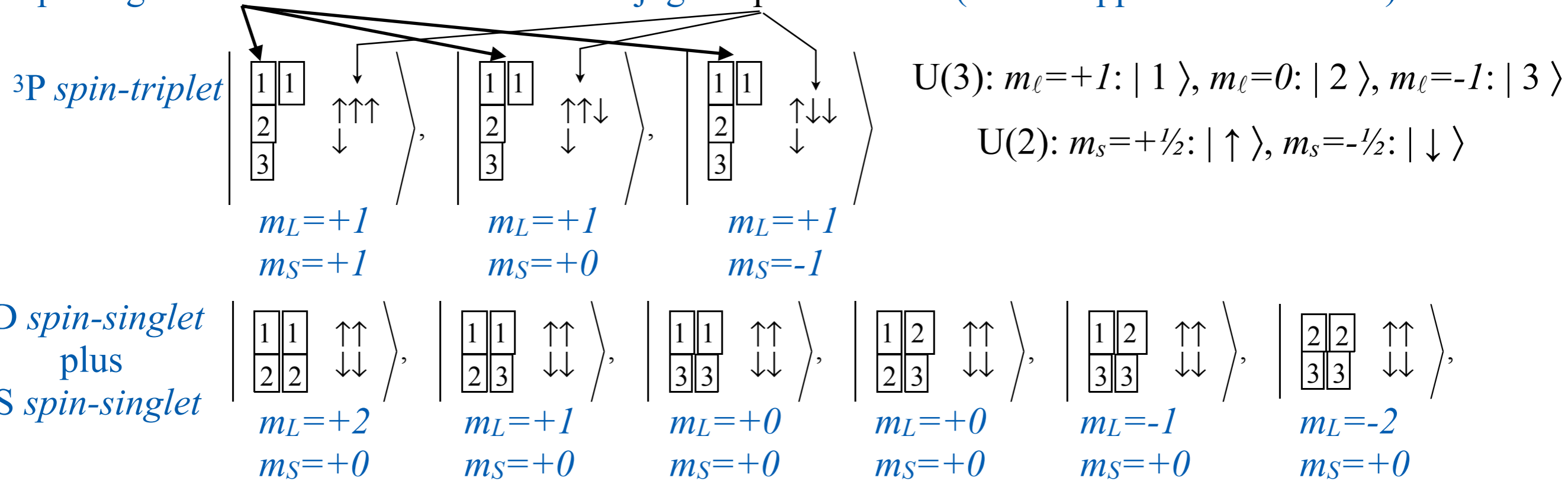

These involve fairly complicated S_n -coupled $U(3)\times U(2)$ combinations that will be developed later.

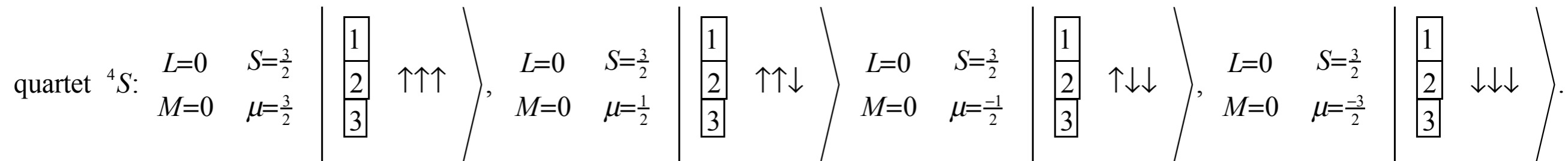

4.16.18 class 23: *Symmetry Principles for
Advanced Atomic-Molecular-Optical-Physics*
William G. Harter - University of Arkansas

$(S_n)^*(U(m))$ shell model of electrostatic quadrupole-quadrupole-e interactions

Marrying spin $s=1/2$ and orbital $\ell=1$ together: $U(3)\times U(2)$

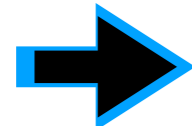
 The $\ell=1$ p -shell in a nutshell

$U(6)\supset U(3)\times U(2)$ approach: Coupling spin-orbit ($s=1/2$, $\ell=1$) tableaus

Introducing atomic spin-orbit state assembly formula

Slater determinants

p -shell Spin-orbit calculations (not finished)

Clebsch Gordan coefficients. (Rev. Mod. Phys. annual gift)

S_n projection for atomic spin and orbit states

Review of Mach-Mock (particle-state) principle

Tableau P-operators on orbits

Tableau P-operators on spin

Fermi-Dirac-Pauli anti-symmetric p^3 -states

Boson operators and symmetric p^2 -states

Connecting to angular momentum

Projecting to angular momentum

The $\ell=1$ p -shell in a nutshell

quartet 4S :

$$\begin{array}{c}
 L=0 \quad S=\frac{3}{2} \\
 M=0 \quad \mu=\frac{3}{2}
 \end{array}
 \left| \begin{array}{c} 1 \\ 2 \\ 3 \end{array} \right\rangle \uparrow\uparrow\uparrow, \quad
 \begin{array}{c}
 L=0 \quad S=\frac{3}{2} \\
 M=0 \quad \mu=\frac{1}{2}
 \end{array}
 \left| \begin{array}{c} 1 \\ 2 \\ 3 \end{array} \right\rangle \uparrow\uparrow\downarrow, \quad
 \begin{array}{c}
 L=0 \quad S=\frac{3}{2} \\
 M=0 \quad \mu=-\frac{1}{2}
 \end{array}
 \left| \begin{array}{c} 1 \\ 2 \\ 3 \end{array} \right\rangle \uparrow\downarrow\downarrow, \quad
 \begin{array}{c}
 L=0 \quad S=\frac{3}{2} \\
 M=0 \quad \mu=-\frac{3}{2}
 \end{array}
 \left| \begin{array}{c} 1 \\ 2 \\ 3 \end{array} \right\rangle \downarrow\downarrow\downarrow.$$

Doublet 2D , $M=2$:

$$\begin{array}{c}
 L=2, \quad S=\frac{1}{2} \\
 M=2, \quad \mu=\frac{1}{2}
 \end{array}
 \left| \begin{array}{c} 1 \quad 1 \\ 2 \end{array} \right\rangle \uparrow\uparrow \downarrow, \quad
 \begin{array}{c}
 L=2, \quad S=-\frac{1}{2} \\
 M=2, \quad \mu=\frac{1}{2}
 \end{array}
 \left| \begin{array}{c} 1 \quad 1 \\ 2 \end{array} \right\rangle \uparrow\downarrow \downarrow.$$

Doublet 2D , $M=1$:

$$\begin{array}{c}
 L=2, \quad S=\frac{1}{2} \\
 M=1, \quad \mu=\frac{1}{2}
 \end{array}
 \frac{1}{\sqrt{2}} \left| \begin{array}{c} 1 \quad 2 \\ 2 \end{array} \right\rangle \uparrow\uparrow \downarrow, \quad
 \begin{array}{c}
 L=2, \quad S=\frac{1}{2} \\
 M=1, \quad \mu=-\frac{1}{2}
 \end{array}
 + \frac{1}{\sqrt{2}} \left| \begin{array}{c} 1 \quad 2 \\ 2 \end{array} \right\rangle \uparrow\downarrow \downarrow, \\
 + \frac{1}{\sqrt{2}} \left| \begin{array}{c} 1 \quad 1 \\ 3 \end{array} \right\rangle \uparrow\uparrow \downarrow, \quad
 + \frac{1}{\sqrt{2}} \left| \begin{array}{c} 1 \quad 1 \\ 3 \end{array} \right\rangle \uparrow\downarrow \downarrow,$$

Doublet 2P , $M=1$:

$$\begin{array}{c}
 L=1, \quad S=\frac{1}{2} \\
 M=1, \quad \mu=\frac{1}{2}
 \end{array}
 \frac{1}{\sqrt{2}} \left| \begin{array}{c} 1 \quad 2 \\ 2 \end{array} \right\rangle \uparrow\uparrow \downarrow, \quad
 \begin{array}{c}
 L=1, \quad S=\frac{1}{2} \\
 M=1, \quad \mu=-\frac{1}{2}
 \end{array}
 + \frac{1}{\sqrt{2}} \left| \begin{array}{c} 1 \quad 2 \\ 2 \end{array} \right\rangle \uparrow\downarrow \downarrow, \\
 - \frac{1}{\sqrt{2}} \left| \begin{array}{c} 1 \quad 1 \\ 3 \end{array} \right\rangle \uparrow\uparrow \downarrow, \quad
 - \frac{1}{\sqrt{2}} \left| \begin{array}{c} 1 \quad 1 \\ 3 \end{array} \right\rangle \uparrow\downarrow \downarrow,$$

Doublet 2D , $M=0$:

$$\begin{array}{c}
 L=2, \quad S=\frac{1}{2} \\
 M=0, \quad \mu=\frac{1}{2}
 \end{array}
 \frac{\sqrt{3}}{2} \left| \begin{array}{c} 1 \quad 2 \\ 3 \end{array} \right\rangle \uparrow\uparrow \downarrow, \quad
 \begin{array}{c}
 L=2, \quad S=\frac{1}{2} \\
 M=0, \quad \mu=-\frac{1}{2}
 \end{array}
 + \frac{\sqrt{3}}{2} \left| \begin{array}{c} 1 \quad 2 \\ 3 \end{array} \right\rangle \uparrow\downarrow \downarrow, \\
 + \frac{1}{2} \left| \begin{array}{c} 1 \quad 3 \\ 2 \end{array} \right\rangle \uparrow\uparrow \downarrow, \quad
 + \frac{1}{2} \left| \begin{array}{c} 1 \quad 3 \\ 2 \end{array} \right\rangle \uparrow\downarrow \downarrow,$$

Doublet 2P , $M=0$:

$$\begin{array}{c}
 L=1, \quad S=\frac{1}{2} \\
 M=0, \quad \mu=\frac{1}{2}
 \end{array}
 \frac{-1}{2} \left| \begin{array}{c} 1 \quad 2 \\ 3 \end{array} \right\rangle \uparrow\uparrow \downarrow, \quad
 \begin{array}{c}
 L=1, \quad S=\frac{1}{2} \\
 M=0, \quad \mu=-\frac{1}{2}
 \end{array}
 \frac{-1}{2} \left| \begin{array}{c} 1 \quad 2 \\ 3 \end{array} \right\rangle \uparrow\downarrow \downarrow, \\
 + \frac{\sqrt{3}}{2} \left| \begin{array}{c} 1 \quad 1 \\ 3 \end{array} \right\rangle \uparrow\uparrow \downarrow, \quad
 + \frac{\sqrt{3}}{2} \left| \begin{array}{c} 1 \quad 3 \\ 2 \end{array} \right\rangle \uparrow\downarrow \downarrow,$$

⋮

⋮

($M=-1$ row)

⋮

⋮

Doublet 2D , $M=-2$:

$$\begin{array}{c}
 L=2, \quad S=\frac{1}{2} \\
 M=-2, \quad \mu=\frac{1}{2}
 \end{array}
 \left| \begin{array}{c} 2 \quad 3 \\ 3 \end{array} \right\rangle \uparrow\uparrow \downarrow, \quad
 \begin{array}{c}
 L=2, \quad S=\frac{1}{2} \\
 M=-2, \quad \mu=-\frac{1}{2}
 \end{array}
 \left| \begin{array}{c} 2 \quad 3 \\ 3 \end{array} \right\rangle \uparrow\downarrow \downarrow$$

U(3)×U(2) approach: Coupling total orbit-L tableaux to total spin S tableaux

A state satisfying Pauli-antisymmetry (Exclusion principle) can be simply represented by putting an orbital tableaux next to a conjugate spin tableaux. (Rows flipped with columns)

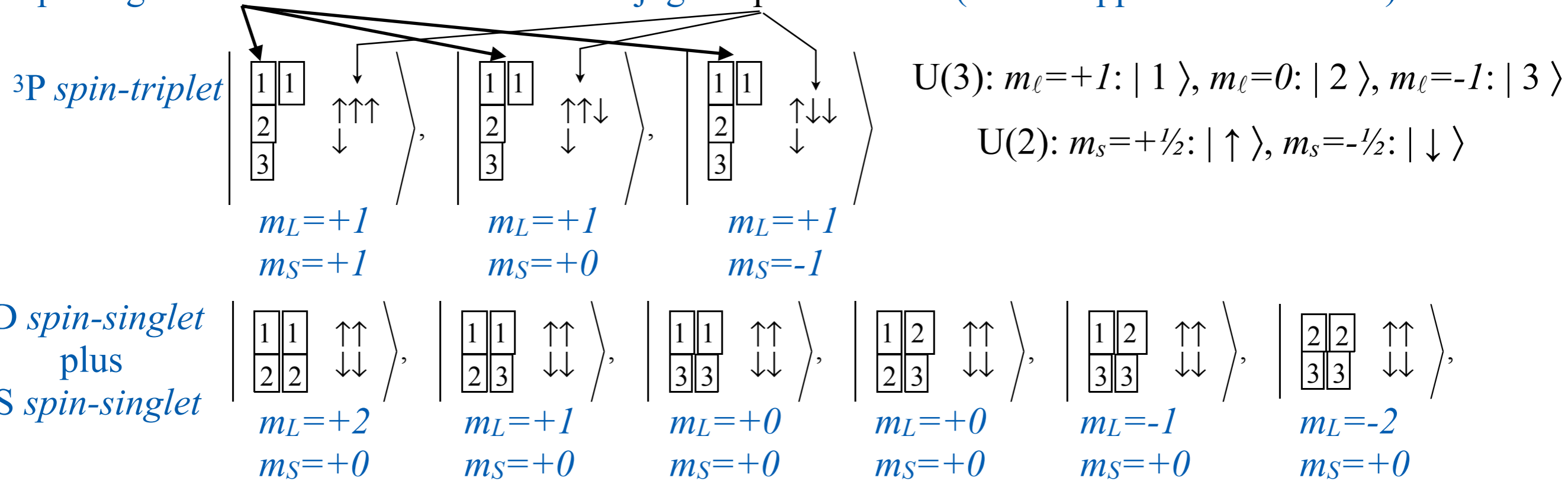

These involve fairly complicated S_n -coupled U(3)×U(2) combinations that will be developed later.

An elementary development using U(6) combinations of so called *Slater determinants* is done first.

4.16.18 class 23: *Symmetry Principles for
Advanced Atomic-Molecular-Optical-Physics*
William G. Harter - University of Arkansas

$(S_n)^*(U(m))$ shell model of electrostatic quadrupole-quadrupole-e interactions

Marrying spin $s=1/2$ and orbital $\ell=1$ together: $U(3)\times U(2)$

The $\ell=1$ p -shell in a nutshell

➔ $U(6)\supset U(3)\times U(2)$ approach: Coupling spin-orbit ($s=1/2, \ell=1$) tableaus

Introducing atomic spin-orbit state assembly formula

Slater determinants

p -shell Spin-orbit calculations (not finished)

Clebsch Gordan coefficients. (Rev. Mod. Phys. annual gift)

S_n projection for atomic spin and orbit states

Review of Mach-Mock (particle-state) principle

Tableau P-operators on orbits

Tableau P-operators on spin

Fermi-Dirac-Pauli anti-symmetric p^3 -states

Boson operators and symmetric p^2 -states

Connecting to angular momentum

Projecting to angular momentum

$U(6) \supset U(3) \times U(2)$ approach: Coupling spin-orbit ($s=1/2, \ell=1$) tableaus

Six states of a single ($s=1/2$) electron in ($\ell=1$) p-shell labeled by a to f .

$U(6)$ bases: $\{|a\rangle \equiv |1\uparrow\rangle, |b\rangle \equiv |1\downarrow\rangle, |c\rangle \equiv |2\uparrow\rangle, |d\rangle \equiv |2\downarrow\rangle, |e\rangle \equiv |3\uparrow\rangle, |f\rangle \equiv |3\downarrow\rangle\}$

$U(6) \supset U(3) \times U(2)$ approach: Coupling spin-orbit ($s=1/2, \ell=1$) tableaus

Six states of a single ($s=1/2$) electron in ($\ell=1$) p-shell labeled by a to f .

$U(6)$ bases: $\{|a\rangle \equiv |1\uparrow\rangle, |b\rangle \equiv |1\downarrow\rangle, |c\rangle \equiv |2\uparrow\rangle, |d\rangle \equiv |2\downarrow\rangle, |e\rangle \equiv |3\uparrow\rangle, |f\rangle \equiv |3\downarrow\rangle\}$

$U(6)$ tensor operators are outer products of $U(3)$ $v^k_q(\text{orbit})$ with $U(2)$ $v^\lambda_\sigma(\text{spin})$ operators

$$\left\langle \begin{matrix} \ell & \frac{1}{2} \\ m' & \mu' \end{matrix} \left| v^k_\lambda \right. \begin{matrix} \ell & \frac{1}{2} \\ m & \mu \end{matrix} \right\rangle = \left\langle \begin{matrix} \ell \\ m' \end{matrix} \left| v^k_q \right. \begin{matrix} \ell \\ m \end{matrix} \right\rangle \left\langle \begin{matrix} \frac{1}{2} \\ \mu' \end{matrix} \left| v^\lambda_\sigma \right. \begin{matrix} \frac{1}{2} \\ \mu \end{matrix} \right\rangle$$

U(6) ⊃ U(3) × U(2) approach: Coupling spin-orbit ($s=1/2, \ell=1$) tableaus

Six states of a single ($s=1/2$) electron in ($\ell=1$) p-shell labeled by a to f .

U(6) bases: $\{|a\rangle \equiv |1\uparrow\rangle, |b\rangle \equiv |1\downarrow\rangle, |c\rangle \equiv |2\uparrow\rangle, |d\rangle \equiv |2\downarrow\rangle, |e\rangle \equiv |3\uparrow\rangle, |f\rangle \equiv |3\downarrow\rangle\}$

U(6) tensor operators are outer products of U(3) $\mathbf{v}_q^k(\text{orbit})$ with U(2) $\mathbf{v}_\sigma^\lambda(\text{spin})$ operators

$$\left\langle \begin{matrix} \ell & \frac{1}{2} \\ m' & \mu' \end{matrix} \middle| \mathbf{v}_{q\sigma}^{k\lambda} \middle| \begin{matrix} \ell & \frac{1}{2} \\ m & \mu \end{matrix} \right\rangle = \left\langle \begin{matrix} \ell \\ m' \end{matrix} \middle| \mathbf{v}_q^k \middle| \begin{matrix} \ell \\ m \end{matrix} \right\rangle \left\langle \begin{matrix} \frac{1}{2} \\ \mu' \end{matrix} \middle| \mathbf{v}_\sigma^\lambda \middle| \begin{matrix} \frac{1}{2} \\ \mu \end{matrix} \right\rangle$$

$$\langle \mathbf{v}_{\frac{2}{2}}^2 \rangle = \begin{pmatrix} \cdot & \cdot & \cdot \\ \cdot & \cdot & \cdot \\ 1 & \cdot & \cdot \end{pmatrix} \quad \langle \mathbf{v}_{\frac{1}{1}}^2 \rangle = \begin{pmatrix} \cdot & \cdot & \cdot \\ 1 & \cdot & \cdot \\ \cdot & \bar{1} & \cdot \end{pmatrix} \frac{1}{\sqrt{2}} \quad \langle \mathbf{v}_0^2 \rangle = \begin{pmatrix} 1 & \cdot & \cdot \\ \cdot & \bar{2} & \cdot \\ \cdot & \cdot & 1 \end{pmatrix} \frac{1}{\sqrt{6}} \quad \langle \mathbf{v}_1^2 \rangle = \begin{pmatrix} \cdot & \bar{1} & \cdot \\ \cdot & \cdot & 1 \\ \cdot & \cdot & \cdot \end{pmatrix} \frac{1}{\sqrt{2}} \quad \langle \mathbf{v}_2^2 \rangle = \begin{pmatrix} \cdot & \cdot & 1 \\ \cdot & \cdot & \cdot \\ \cdot & \cdot & \cdot \end{pmatrix} \quad \langle \mathbf{v}_{\frac{1}{1}}^1 \rangle = \begin{pmatrix} \cdot & \cdot \\ 1 & \cdot \end{pmatrix} \quad \langle \mathbf{v}_0^1 \rangle = \begin{pmatrix} 1 & \cdot \\ \cdot & \bar{1} \end{pmatrix} \frac{1}{\sqrt{2}} \quad \langle \mathbf{v}_1^1 \rangle = \begin{pmatrix} \cdot & \bar{1} \\ \cdot & \cdot \end{pmatrix}$$

$$\langle \mathbf{v}_{\frac{1}{1}}^1 \rangle = \begin{pmatrix} \cdot & \cdot & \cdot \\ 1 & \cdot & \cdot \\ \cdot & 1 & \cdot \end{pmatrix} \frac{1}{\sqrt{2}} \quad \langle \mathbf{v}_0^1 \rangle = \begin{pmatrix} 1 & \cdot & \cdot \\ \cdot & 0 & \cdot \\ \cdot & \cdot & \bar{1} \end{pmatrix} \frac{1}{\sqrt{2}} \quad \langle \mathbf{v}_1^1 \rangle = \begin{pmatrix} \cdot & \bar{1} & \cdot \\ \cdot & \cdot & \bar{1} \\ \cdot & \cdot & \cdot \end{pmatrix} \frac{1}{\sqrt{2}}$$

Notational compaction:

$\bar{1} \equiv -1, \bar{2} \equiv -2, \text{ etc.}$

$$\langle \mathbf{v}_0^0 \rangle = \begin{pmatrix} 1 & \cdot \\ \cdot & 1 \end{pmatrix} \frac{1}{\sqrt{3}}$$

$$\langle \mathbf{v}_0^0 \rangle = \begin{pmatrix} 1 & \cdot & \cdot \\ \cdot & 1 & \cdot \\ \cdot & \cdot & 1 \end{pmatrix} \frac{1}{\sqrt{3}}$$

$\frac{1}{\sqrt{2}}(-\mathbf{E}_{cb} - \mathbf{E}_{ed}) =$

$$\langle \mathbf{v}_{\frac{11}{11}}^{11} \rangle = \begin{pmatrix} \cdot & \cdot & \cdot & \cdot & \cdot & \cdot \\ \cdot & \cdot & \cdot & \cdot & \cdot & \cdot \\ \cdot & \bar{1} & \cdot & \cdot & \cdot & \cdot \\ \cdot & \cdot & \cdot & \cdot & \cdot & \cdot \\ \cdot & \cdot & \cdot & \bar{1} & \cdot & \cdot \\ \cdot & \cdot & \cdot & \cdot & \cdot & \cdot \end{pmatrix} \frac{1}{\sqrt{2}} \quad \langle \mathbf{v}_{00}^{11} \rangle = \begin{pmatrix} 1 & \cdot & \cdot & \cdot & \cdot & \cdot \\ \cdot & \bar{1} & \cdot & \cdot & \cdot & \cdot \\ \cdot & \cdot & \cdot & \cdot & \cdot & \cdot \\ \cdot & \cdot & \cdot & \cdot & \cdot & \cdot \\ \cdot & \cdot & \cdot & \cdot & \bar{1} & \cdot \\ \cdot & \cdot & \cdot & \cdot & \cdot & 1 \end{pmatrix} \frac{1}{2} \quad \langle \mathbf{v}_{\frac{11}{11}}^{11} \rangle = \begin{pmatrix} \cdot & \cdot & \cdot & \cdot & \cdot & \cdot \\ \cdot & \cdot & \cdot & \cdot & \cdot & \cdot \\ \cdot & \cdot & \cdot & \cdot & \cdot & \cdot \\ \cdot & \cdot & \cdot & \cdot & \cdot & \cdot \\ \cdot & \cdot & \cdot & \cdot & \bar{1} & \cdot \\ \cdot & \cdot & \cdot & \cdot & \cdot & \cdot \end{pmatrix} \frac{1}{\sqrt{2}} = \mathbf{v}_1^1 \otimes \mathbf{v}_{\frac{1}{1}}^1 = \frac{1}{\sqrt{2}} \begin{pmatrix} \cdot & \bar{1} & \cdot \\ \cdot & \cdot & \bar{1} \\ \cdot & \cdot & \cdot \end{pmatrix} \otimes \begin{pmatrix} \cdot & \cdot \\ 1 & \cdot \end{pmatrix} = \frac{1}{\sqrt{2}}(-\mathbf{E}_{bc} - \mathbf{E}_{de})$$

$$\langle \mathbf{v}_{\frac{11}{11}}^{11} \rangle = \begin{pmatrix} \cdot & \cdot & \cdot & \cdot & \cdot & \cdot \\ \cdot & \cdot & \cdot & \cdot & \cdot & \cdot \\ \cdot & \cdot & \cdot & \cdot & \cdot & \cdot \\ 1 & \cdot & \cdot & \cdot & \cdot & \cdot \\ \cdot & \cdot & \cdot & \cdot & \cdot & \cdot \\ \cdot & \cdot & \cdot & \cdot & \cdot & \cdot \\ \cdot & \cdot & 1 & \cdot & \cdot & \cdot \\ \cdot & \cdot & \cdot & 1 & \cdot & \cdot \\ \cdot & \cdot & \cdot & \cdot & 1 & \cdot \\ \cdot & \cdot & \cdot & \cdot & \cdot & 1 \end{pmatrix} \frac{1}{\sqrt{2}} \quad \langle \mathbf{v}_{00}^{00} \rangle = \begin{pmatrix} 1 & \cdot & \cdot & \cdot & \cdot & \cdot \\ \cdot & 1 & \cdot & \cdot & \cdot & \cdot \\ \cdot & \cdot & 1 & \cdot & \cdot & \cdot \\ \cdot & \cdot & \cdot & 1 & \cdot & \cdot \\ \cdot & \cdot & \cdot & \cdot & 1 & \cdot \\ \cdot & \cdot & \cdot & \cdot & \cdot & 1 \end{pmatrix} \frac{1}{\sqrt{6}} \quad \langle \mathbf{v}_{\frac{11}{11}}^{11} \rangle = \begin{pmatrix} \cdot & \cdot & \cdot & 1 & \cdot & \cdot \\ \cdot & \cdot & \cdot & \cdot & \cdot & \cdot \\ \cdot & \cdot & \cdot & \cdot & \cdot & \cdot \\ \cdot & \cdot & \cdot & \cdot & \cdot & 1 \\ \cdot & \cdot & \cdot & \cdot & \cdot & \cdot \\ \cdot & \cdot & \cdot & \cdot & \cdot & \cdot \end{pmatrix} \frac{1}{\sqrt{2}}$$

4.16.18 class 23: *Symmetry Principles for
Advanced Atomic-Molecular-Optical-Physics*
William G. Harter - University of Arkansas

$(S_n)^*(U(m))$ shell model of electrostatic quadrupole-quadrupole-e interactions

Marrying spin $s=1/2$ and orbital $\ell=1$ together: $U(3)\times U(2)$

The $\ell=1$ p -shell in a nutshell

$U(6)\supset U(3)\times U(2)$ approach: Coupling spin-orbit ($s=1/2$, $\ell=1$) tableaus

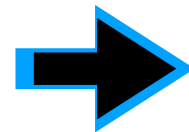

Introducing atomic spin-orbit state assembly formula

Slater determinants

p -shell Spin-orbit calculations (not finished)

Clebsch Gordan coefficients. (Rev. Mod. Phys. annual gift)

S_n projection for atomic spin and orbit states

Review of Mach-Mock (particle-state) principle

Tableau P-operators on orbits

Tableau P-operators on spin

Fermi-Dirac-Pauli anti-symmetric p^3 -states

Boson operators and symmetric p^2 -states

Connecting to angular momentum

Projecting to angular momentum

p-shell Spin-orbit calculation

4.16.18 class 23: *Symmetry Principles for
Advanced Atomic-Molecular-Optical-Physics*
William G. Harter - University of Arkansas

$(S_n)^*(U(m))$ shell model of electrostatic quadrupole-quadrupole-e interactions

Marrying spin $s=1/2$ and orbital $\ell=1$ together: $U(3)\times U(2)$

The $\ell=1$ p -shell in a nutshell

$U(6)\supset U(3)\times U(2)$ approach: Coupling spin-orbit ($s=1/2$, $\ell=1$) tableaus

Introducing atomic spin-orbit state assembly formula

Slater determinants

p -shell Spin-orbit calculations (not finished)

→ Clebsch Gordan coefficients. (Rev. Mod. Phys. annual gift)

S_n projection for atomic spin and orbit states

Review of Mach-Mock (particle-state) principle

Tableau P-operators on orbits

Tableau P-operators on spin

Fermi-Dirac-Pauli anti-symmetric p^3 -states

Boson operators and symmetric p^2 -states

Connecting to angular momentum

Projecting to angular momentum

Clebsch Gordan coefficients (Rev. Mod. Phys. annual gift)

$1/2 \times 1/2$

1
+1/2 +1/2
+1/2 -1/2
-1/2 +1/2
-1/2 -1/2

 $Y_1^0 = \sqrt{\frac{3}{4\pi}} \cos \theta$
 $Y_1^1 = -\sqrt{\frac{3}{8\pi}} \sin \theta e^{i\phi}$
 $2 \times 1/2$

5/2
+5/2
+2 +1/2
+2 -1/2
+1 +1/2

m_1	m_2	Coefficients
m_1	m_2	
\dots	\dots	
\dots	\dots	

 $Y_2^0 = \sqrt{\frac{5}{4\pi}} \left(\frac{3}{2} \cos^2 \theta - \frac{1}{2} \right)$
 $Y_2^1 = -\sqrt{\frac{15}{8\pi}} \sin \theta \cos \theta e^{i\phi}$
 $Y_2^2 = \frac{1}{4} \sqrt{\frac{15}{2\pi}} \sin^2 \theta e^{2i\phi}$
 $1 \times 1/2$

3/2
+3/2
+1 -1/2
0 +1/2

 1×1

2
+2
+1 0
0 +1

 2×1

3
+3
+2 0
+1 +1

 $3/2 \times 1$

5/2
+5/2
+3/2 +1
+3/2 0
+1/2 +1

 $3/2 \times 1/2$

2
+2
+3/2 +1/2
+3/2 -1/2
+1/2 +1/2

 1×1

2
+2
+1 0
0 +1

 2×1

3
+3
+2 0
+1 +1

 $3/2 \times 1/2$

3
+3
+2 +1
+2 0
+1 +1

 1×1

2
+2
+1 0
0 +1

 $Y_\ell^{-m} = (-1)^m Y_\ell^{m*}$
 $d_{m,0}^\ell = \sqrt{\frac{4\pi}{2\ell+1}} Y_\ell^m e^{-im\phi}$
 $d_{m',m}^j = (-1)^{m-m'} d_{m,m'}^j = d_{-m,-m'}^j$
 $3/2 \times 3/2$

3
+3
+3/2 +3/2
+3/2 +1/2
+1/2 +3/2

 $d_{0,0}^1 = \cos \theta$
 $d_{1/2,1/2}^{1/2} = \cos \frac{\theta}{2}$
 $d_{1/2,-1/2}^{1/2} = -\sin \frac{\theta}{2}$
 $d_{1,1}^1 = \frac{1 + \cos \theta}{2}$
 $d_{1,0}^1 = -\frac{\sin \theta}{\sqrt{2}}$
 $d_{1,-1}^1 = \frac{1 - \cos \theta}{2}$
 $2 \times 3/2$

7/2
+7/2
+2 +3/2
+2 +1/2
+1 +3/2

 2×2

4
+4
+2 +2
+2 +1
+1 +2

 $d_{3/2,3/2}^{3/2} = \frac{1 + \cos \theta}{2} \cos \frac{\theta}{2}$
 $d_{3/2,1/2}^{3/2} = -\sqrt{3} \frac{1 + \cos \theta}{2} \sin \frac{\theta}{2}$
 $d_{3/2,-1/2}^{3/2} = \sqrt{3} \frac{1 - \cos \theta}{2} \cos \frac{\theta}{2}$
 $d_{3/2,-3/2}^{3/2} = -\frac{1 - \cos \theta}{2} \sin \frac{\theta}{2}$
 $d_{1/2,1/2}^{3/2} = \frac{3 \cos \theta - 1}{2} \cos \frac{\theta}{2}$
 $d_{1/2,-1/2}^{3/2} = -\frac{3 \cos \theta + 1}{2} \sin \frac{\theta}{2}$
 $d_{2,2}^2 = \left(\frac{1 + \cos \theta}{2} \right)^2$
 $d_{2,1}^2 = -\frac{1 + \cos \theta}{2} \sin \theta$
 $d_{2,0}^2 = \frac{\sqrt{6}}{4} \sin^2 \theta$
 $d_{2,-1}^2 = -\frac{1 - \cos \theta}{2} \sin \theta$
 $d_{2,-2}^2 = \left(\frac{1 - \cos \theta}{2} \right)^2$
 $d_{1,1}^2 = \frac{1 + \cos \theta}{2} (2 \cos \theta - 1)$
 $d_{1,0}^2 = -\sqrt{\frac{3}{2}} \sin \theta \cos \theta$
 $d_{1,-1}^2 = \frac{1 - \cos \theta}{2} (2 \cos \theta + 1)$
 $d_{0,0}^2 = \left(\frac{3}{2} \cos^2 \theta - \frac{1}{2} \right)$

4.16.18 class 23: *Symmetry Principles for Advanced Atomic-Molecular-Optical-Physics* William G. Harter - University of Arkansas

$(S_n)^*(U(m))$ shell model of electrostatic quadrupole-quadrupole-e interactions

Marrying spin $s=1/2$ and orbital $\ell=1$ together: $U(3)\times U(2)$

The $\ell=1$ p -shell in a nutshell

$U(6)\supset U(3)\times U(2)$ approach: Coupling spin-orbit ($s=1/2, \ell=1$) tableaus

Introducing atomic spin-orbit state assembly formula

Slater determinants

p -shell Spin-orbit calculations (not finished)

Clebsch Gordan coefficients. (Rev. Mod. Phys. annual gift)

S_n projection for atomic spin and orbit states

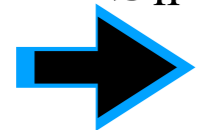

Review of Mach-Mock (particle-state) principle

Tableau P-operators on orbits

Tableau P-operators on spin

Fermi-Dirac-Pauli anti-symmetric p^3 -states

Boson operators and symmetric p^2 -states

Connecting to angular momentum

Projecting to angular momentum

S_n projection for atomic spin and orbit states

Review of Lect. 20 p.37 to 41

$D3 < C3v$ nomogram
AMOP Class 12 pdf p30

$D3 < D6$ nomogram
AMOP Class 14 pdf p28

Fig. 25.3.0 QTforCA Unit 8 Ch.25 pdf p28

(a) Lab or State Based Operators

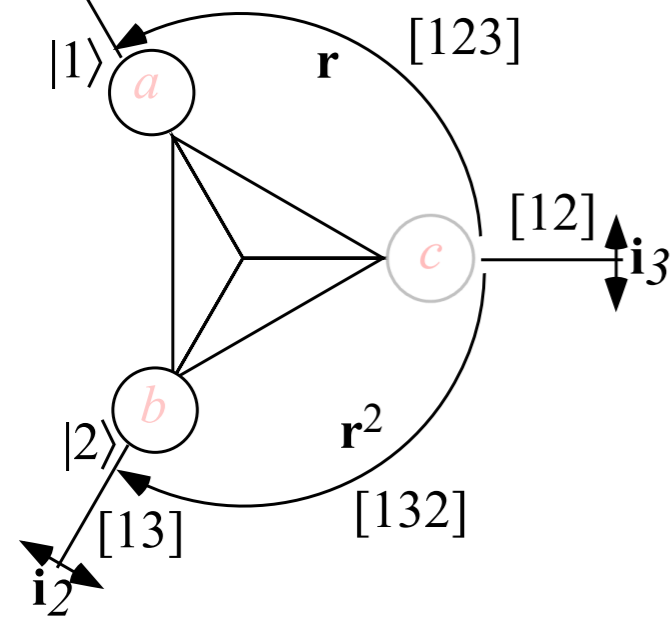

(b) Body or Particle Based Operators

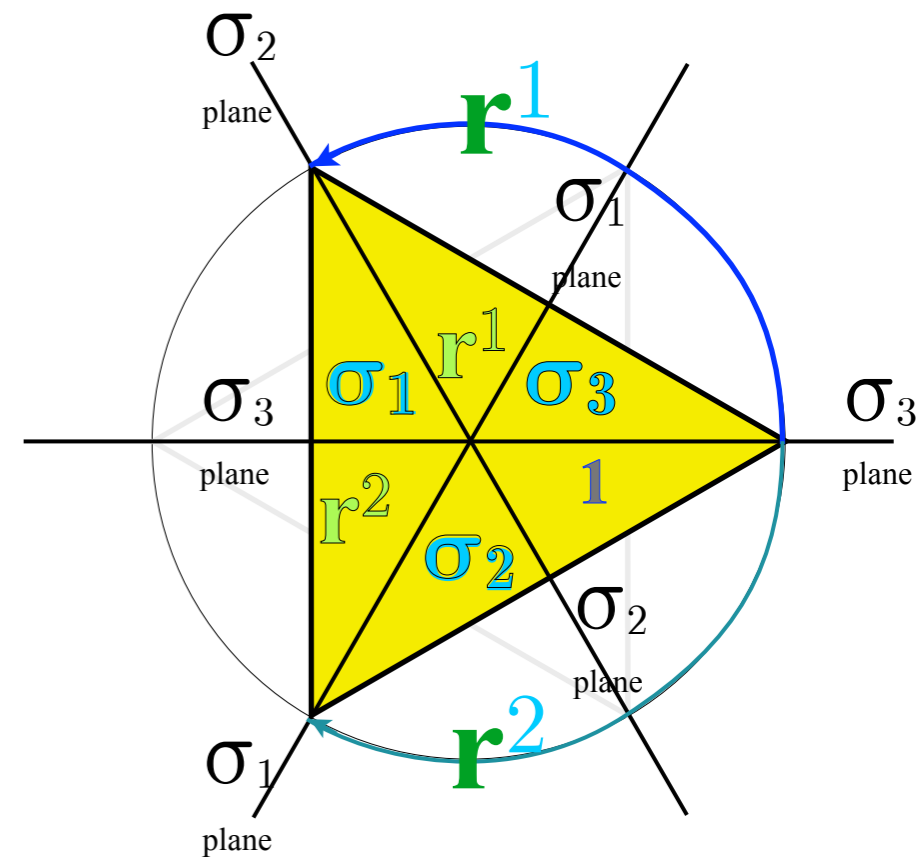
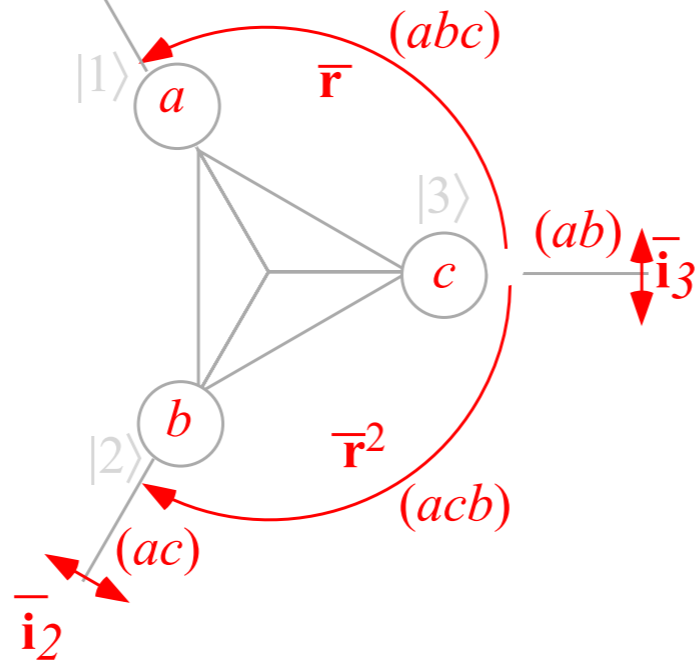

C_{3v} gg^\dagger form	1	r^2	r^1	σ_1	σ_2	σ_3
$(a)(b)(c) = 1$	1	r^2	r^1	σ_1	σ_2	σ_3
$(abc) = r^1$	r^1	1	r^2	σ_2	σ_3	σ_1
$(acb) = r^2$	r^2	r^1	1	σ_3	σ_1	σ_2
$(bc) = \sigma_1$	σ_1	σ_2	σ_3	1	r^2	r^1
$(ac) = \sigma_2$	σ_2	σ_3	σ_1	r^1	1	r^2
$(ab) = \sigma_3$	σ_3	σ_1	σ_2	r^2	r^1	1

S_n projection for atomic spin and orbit states

Fig. 25.3.1 QTforCA Unit 8 Ch.25 pdf p29

Review of Lect. 20 p.37 to 41

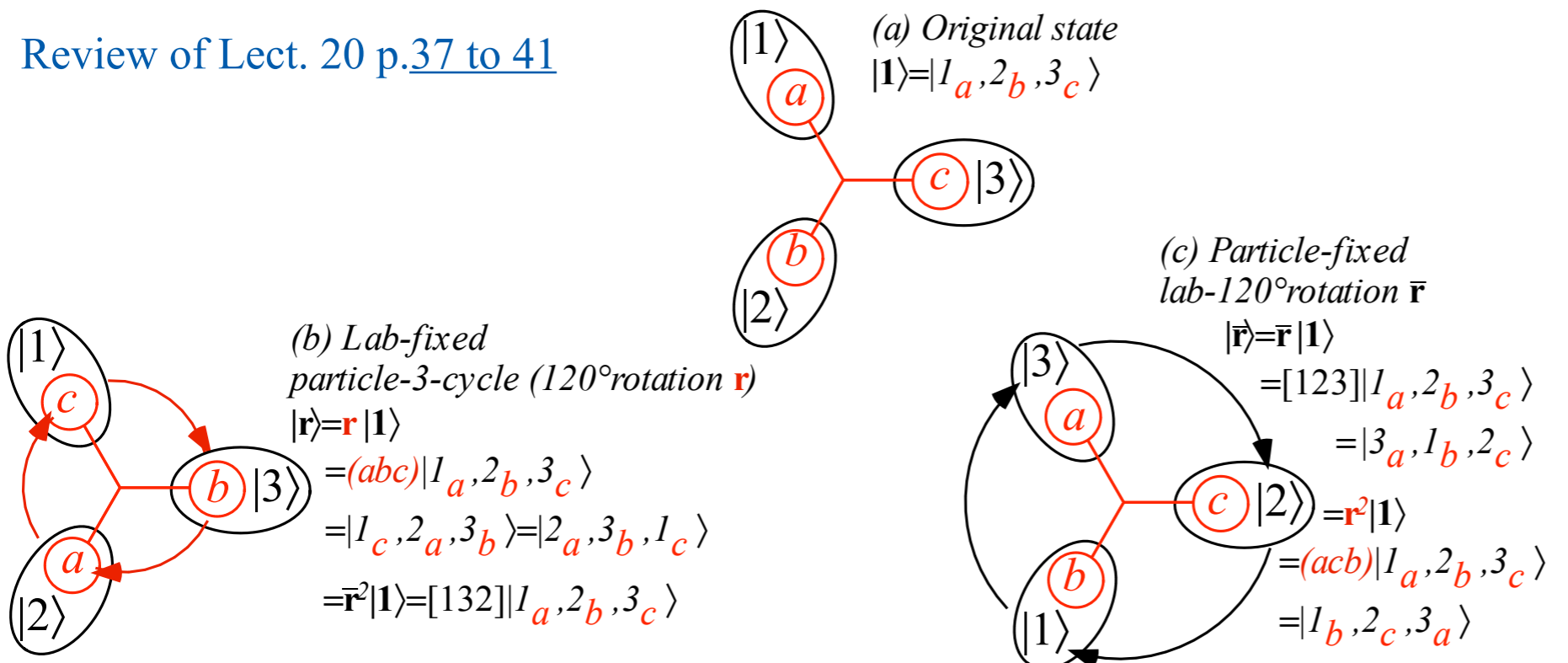

$$[132]|1_a, 2_b, 3_c\rangle = |2_a, 3_b, 1_c\rangle$$

$$[123]|1_a, 2_b, 3_c\rangle = |3_a, 1_b, 2_c\rangle$$

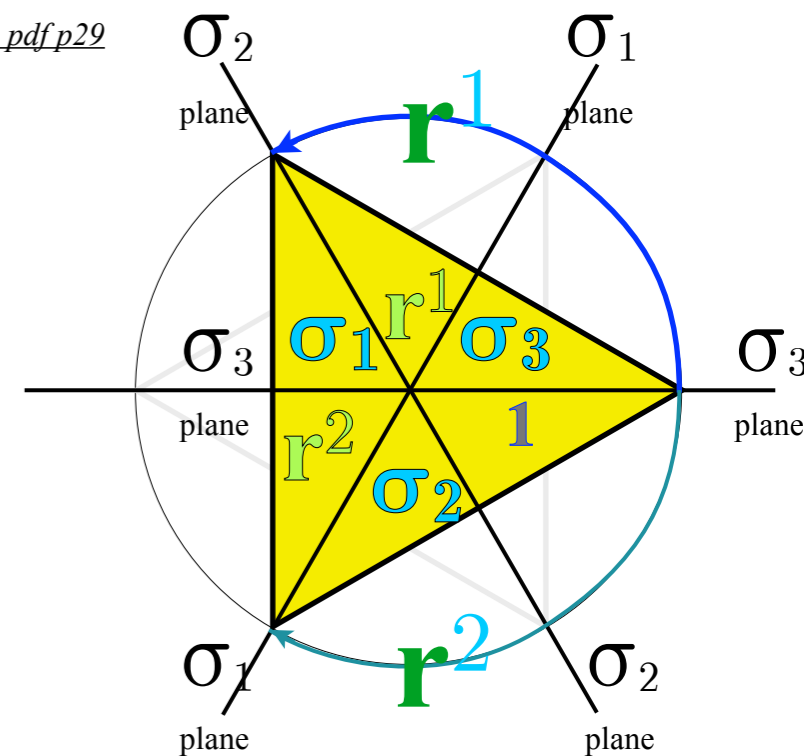

1	r^2	r	i_1	i_2	i_3
r	1	r^2	i_2	i_3	i_1
r^2	r	1	i_3	i_1	i_2
i_1	i_2	i_3	1	r^2	r
i_2	i_3	i_1	r	1	r^2
i_3	i_1	i_2	r^2	r	1

(1)	(acb)	(abc)	(bc)	(ac)	(ab)
(abc)	(1)	(acb)	(ac)	(ab)	(bc)
(acb)	(abc)	(1)	(ab)	(bc)	(ac)
(bc)	(ac)	(ab)	(1)	(acb)	(abc)
(ac)	(ab)	(bc)	(abc)	(1)	(acb)
(ab)	(bc)	(ac)	(acb)	(abc)	(1)

[1]	[132]	[123]	[23]	[13]	[12]
[123]	[1]	[132]	[13]	[12]	[23]
[132]	[123]	[1]	[12]	[23]	[13]
[23]	[13]	[12]	[1]	[132]	[123]
[13]	[12]	[23]	[123]	[1]	[132]
[12]	[23]	[13]	[132]	[123]	[1]

C_{3v} gg [†] form	1	r^2	r^1	σ_1	σ_2	σ_3
(a)(b)(c) = 1	1	r^2	r^1	σ_1	σ_2	σ_3
(abc) = r^1	r^1	1	r^2	σ_2	σ_3	σ_1
(acb) = r^2	r^2	r^1	1	σ_3	σ_1	σ_2
(bc) = σ_1	σ_1	σ_2	σ_3	1	r^2	r^1
(ac) = σ_2	σ_2	σ_3	σ_1	r^1	1	r^2
(ab) = σ_3	σ_3	σ_1	σ_2	r^2	r^1	1

Fig. 25.3.1 Relating D₃ and S₃ permutation operations

S_n projection for atomic spin and orbit states

Fig. 25.3.1 QTforCA Unit 8 Ch.25 pdf p29

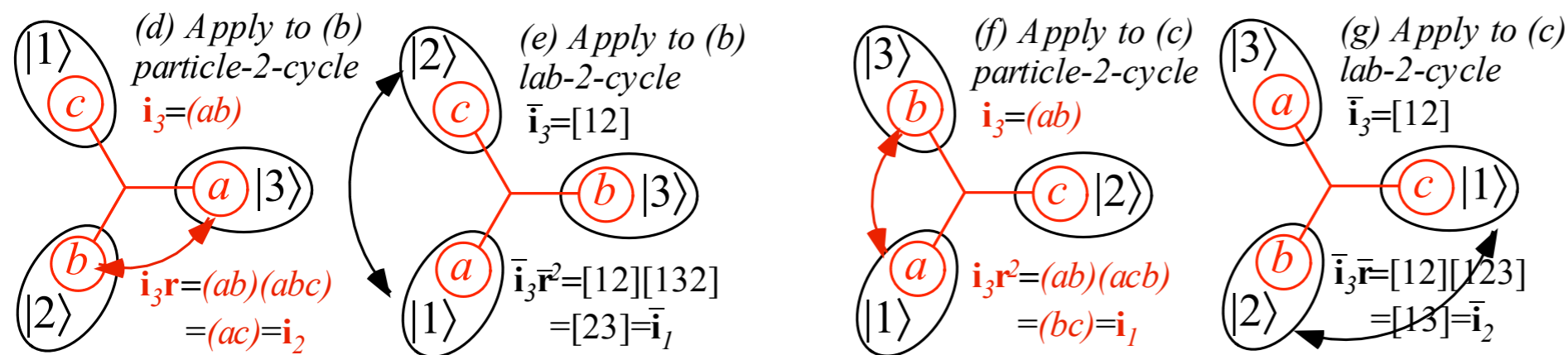
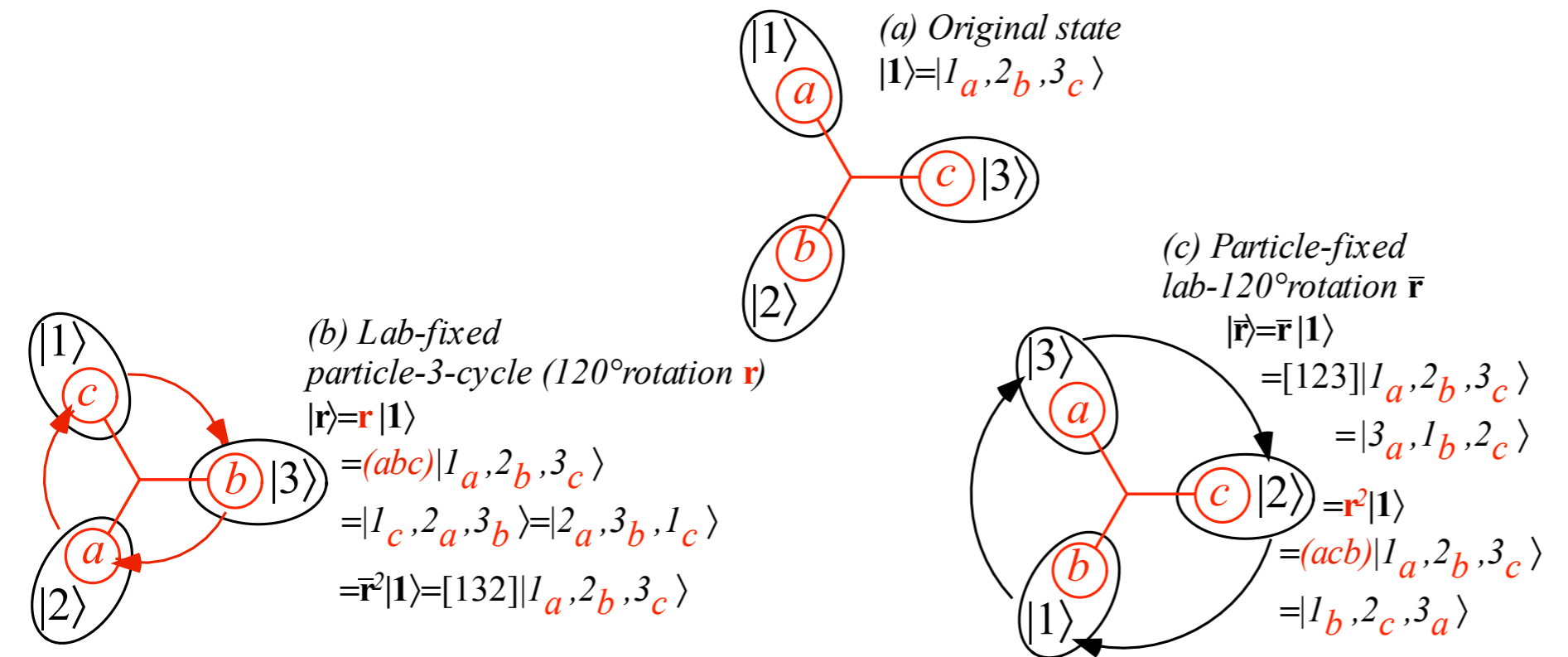

(1)	(acb)	(abc)	(bc)	(ac)	(ab)
(abc)	(1)	(acb)	(ac)	(ab)	(bc)
(acb)	(abc)	(1)	(ab)	(bc)	(ac)
(bc)	(ac)	(ab)	(1)	(acb)	(abc)
(ac)	(ab)	(bc)	(abc)	(1)	(acb)
(ab)	(bc)	(ac)	(acb)	(abc)	(1)

[1]	[132]	[123]	[23]	[13]	[12]
[123]	[1]	[132]	[13]	[12]	[23]
[132]	[123]	[1]	[12]	[23]	[13]
[23]	[13]	[12]	[1]	[132]	[123]
[13]	[12]	[23]	[123]	[1]	[132]
[12]	[23]	[13]	[132]	[123]	[1]

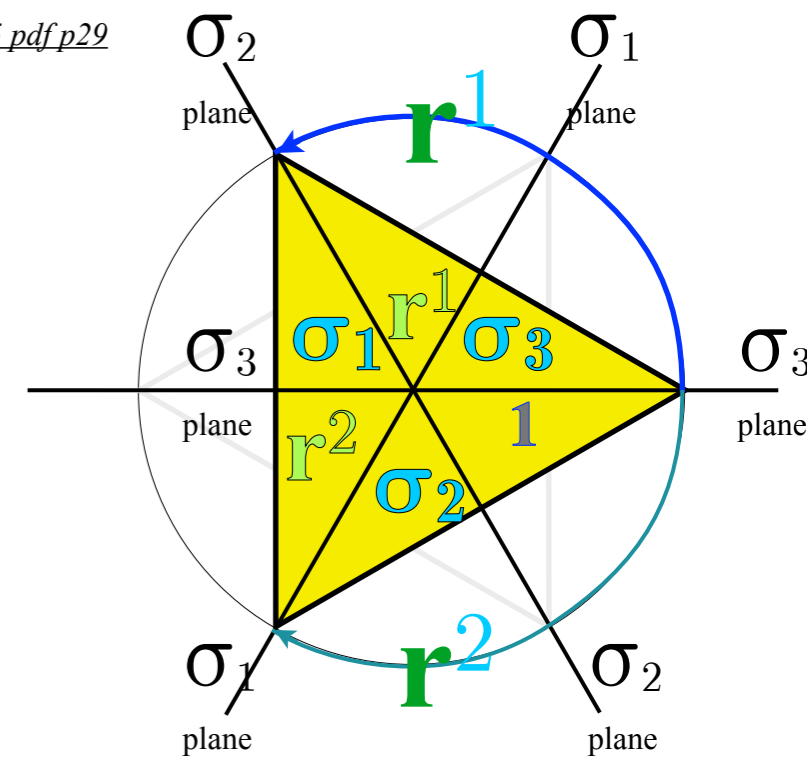

1	r^2	r	i_1	i_2	i_3
r	1	r^2	i_2	i_3	i_1
r^2	r	1	i_3	i_1	i_2
i_1	i_2	i_3	1	r^2	r
i_2	i_3	i_1	r	1	r^2
i_3	i_1	i_2	r^2	r	1

C_{3v} gg † form	1	r^2	r^1	σ_1	σ_2	σ_3
(a)(b)(c) = 1	1	r^2	r^1	σ_1	σ_2	σ_3
(abc) = r^1	r^1	1	r^2	σ_2	σ_3	σ_1
(acb) = r^2	r^2	r^1	1	σ_3	σ_1	σ_2
(bc) = σ_1	σ_1	σ_2	σ_3	1	r^2	r^1
(ac) = σ_2	σ_2	σ_3	σ_1	r^1	1	r^2
(ab) = σ_3	σ_3	σ_1	σ_2	r^2	r^1	1

Fig. 25.3.1 Relating D_3 and S_3 permutation operations

S_n projection for atomic spin and orbit states

Fig. 25.3.1 QTforCA Unit 8 Ch.25 pdf p29

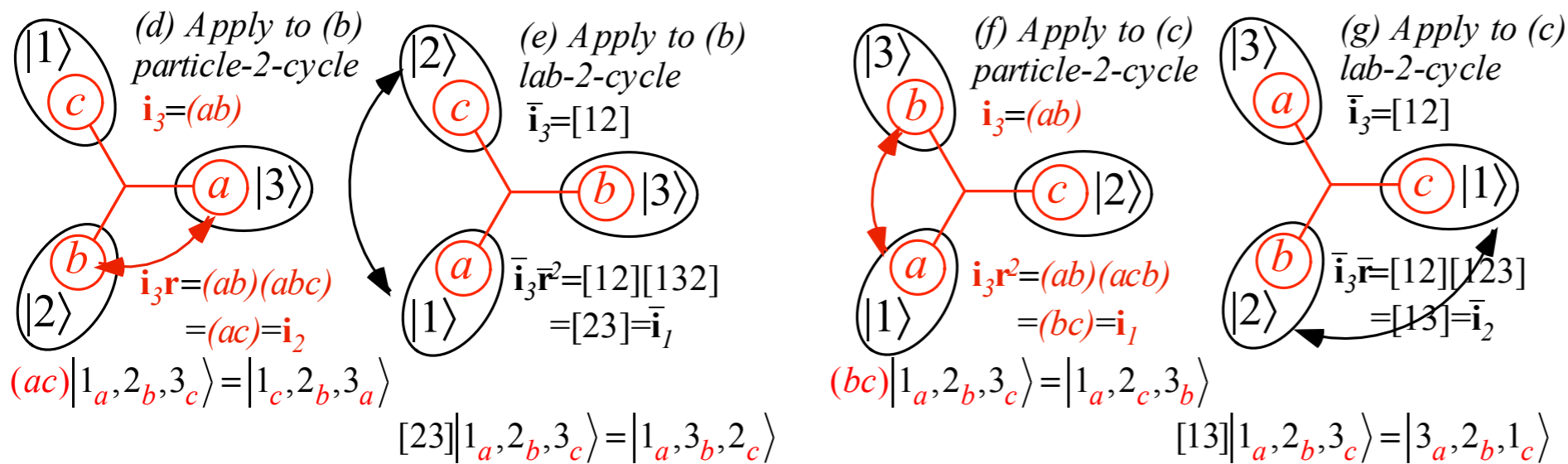
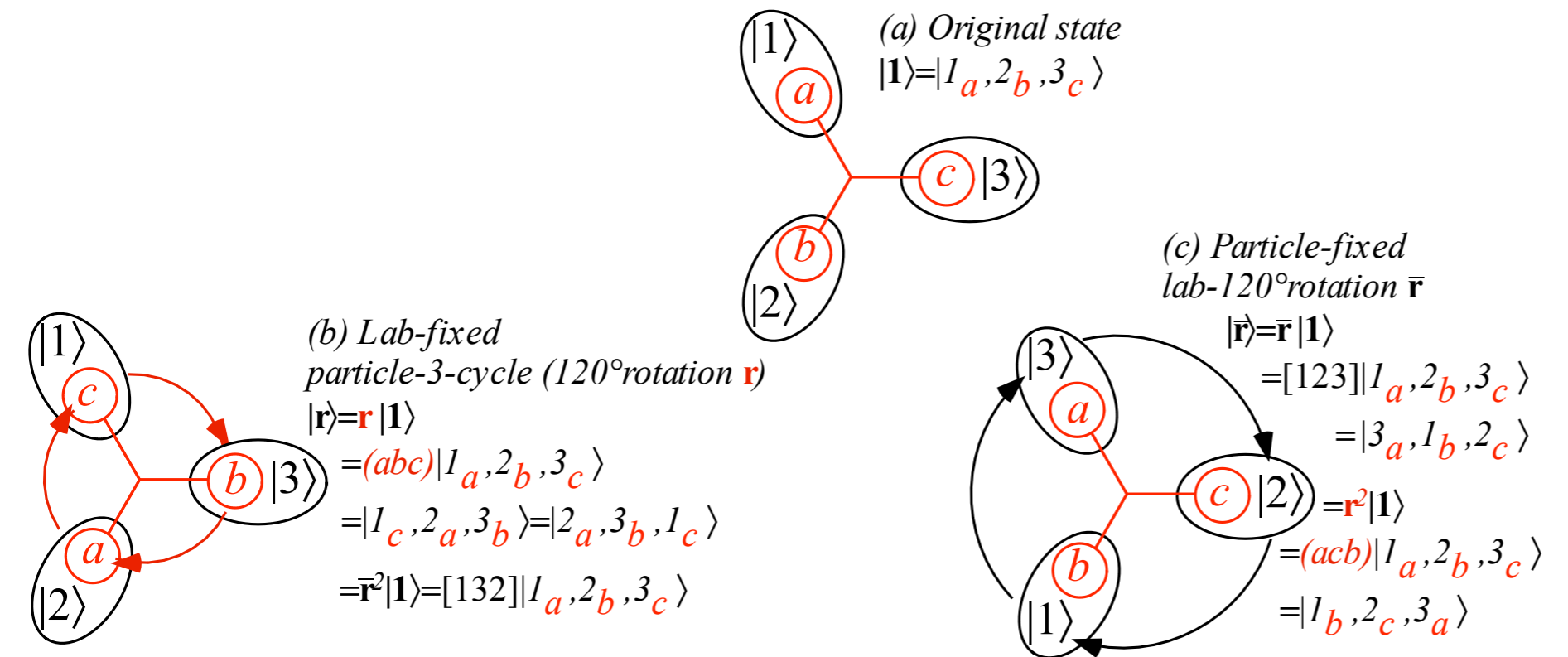

(1)	(acb)	(abc)	(bc)	(ac)	(ab)
(abc)	(1)	(acb)	(ac)	(ab)	(bc)
(acb)	(abc)	(1)	(ab)	(bc)	(ac)
(bc)	(ac)	(ab)	(1)	(acb)	(abc)
(ac)	(ab)	(bc)	(abc)	(1)	(acb)
(ab)	(bc)	(ac)	(acb)	(abc)	(1)

[1]	[132]	[123]	[23]	[13]	[12]
[123]	[1]	[132]	[13]	[12]	[23]
[132]	[123]	[1]	[12]	[23]	[13]
[23]	[13]	[12]	[1]	[132]	[123]
[13]	[12]	[23]	[123]	[1]	[132]
[12]	[23]	[13]	[132]	[123]	[1]

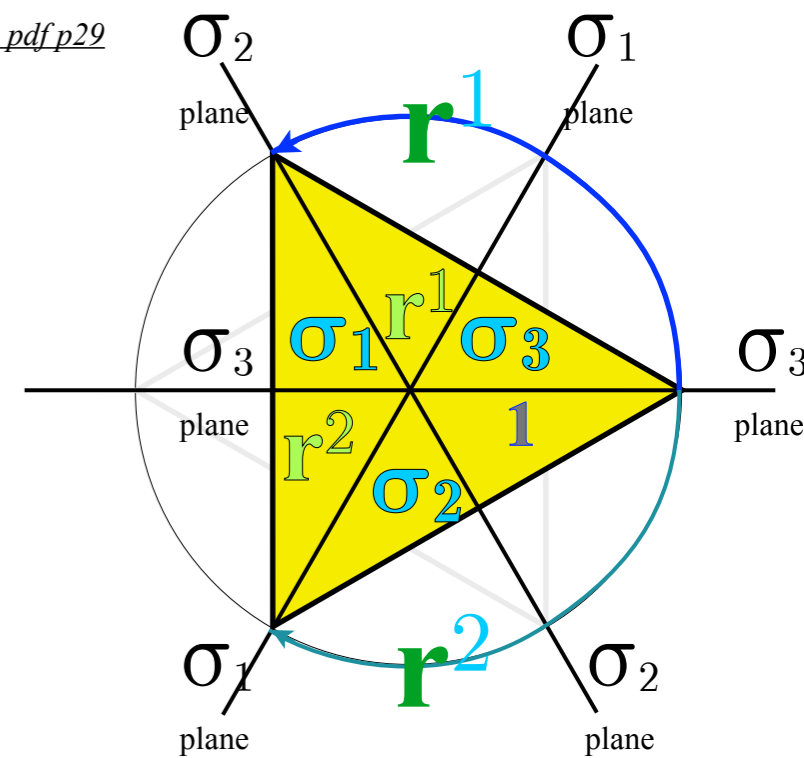

1	r^2	r	i_1	i_2	i_3
r	1	r^2	i_2	i_3	i_1
r^2	r	1	i_3	i_1	i_2
i_1	i_2	i_3	1	r^2	r
i_2	i_3	i_1	r	1	r^2
i_3	i_1	i_2	r^2	r	1

C_{3v} gg † form	1	r^2	r^1	σ_1	σ_2	σ_3
(a)(b)(c) = 1	1	r^2	r^1	σ_1	σ_2	σ_3
(abc) = r^1	r^1	1	r^2	σ_2	σ_3	σ_1
(acb) = r^2	r^2	r^1	1	σ_3	σ_1	σ_2
(bc) = σ_1	σ_1	σ_2	σ_3	1	r^2	r^1
(ac) = σ_2	σ_2	σ_3	σ_1	r^1	1	r^2
(ab) = σ_3	σ_3	σ_1	σ_2	r^2	r^1	1

Fig. 25.3.1 Relating D_3 and S_3 permutation operations

S_n projection for atomic spin and orbit states

(a) Original state
 $|1\rangle = |1_a, 2_b, 3_c\rangle$

(b) Lab-fixed particle-3-cycle (120° rotation \mathbf{r})
 $|\mathbf{r}\rangle = \mathbf{r}|1\rangle = (abc)|1_a, 2_b, 3_c\rangle = |1_c, 2_a, 3_b\rangle = |2_a, 3_b, 1_c\rangle = \mathbf{r}^2|1\rangle = [132]|1_a, 2_b, 3_c\rangle$

(c) Particle-fixed lab- 120° rotation $\bar{\mathbf{r}}$
 $|\bar{\mathbf{r}}\rangle = \bar{\mathbf{r}}|1\rangle = [123]|1_a, 2_b, 3_c\rangle = |3_a, 1_b, 2_c\rangle = \mathbf{r}^2|1\rangle = (acb)|1_a, 2_b, 3_c\rangle = |1_b, 2_c, 3_a\rangle$

(d) Apply to (b) particle-2-cycle $\mathbf{i}_3 = (ab)$
 $\mathbf{i}_3 \mathbf{r} = (ab)(abc) = (ac) = \mathbf{i}_2$
 $(ac)|1_a, 2_b, 3_c\rangle = |1_c, 2_b, 3_a\rangle$

(e) Apply to (b) lab-2-cycle $\bar{\mathbf{i}}_3 = [12]$
 $\bar{\mathbf{i}}_3 \mathbf{r}^2 = [12][132] = [23] = \bar{\mathbf{i}}_1$
 $[23]|1_a, 2_b, 3_c\rangle = |1_a, 3_b, 2_c\rangle = |1_a, 2_c, 3_b\rangle = |2_c, 1_a, 3_b\rangle = |2_c, 3_b, 1_a\rangle = |3_b, 2_c, 1_a\rangle = |3_b, 1_a, 2_c\rangle$

(f) Apply to (c) particle-2-cycle $\mathbf{i}_3 = (ab)$
 $\mathbf{i}_3 \mathbf{r}^2 = (ab)(acb) = (bc) = \mathbf{i}_1$
 $(bc)|1_a, 2_b, 3_c\rangle = |1_a, 2_c, 3_b\rangle$

(g) Apply to (c) lab-2-cycle $\bar{\mathbf{i}}_3 = [12]$
 $\bar{\mathbf{i}}_3 \bar{\mathbf{r}} = [12][123] = [13] = \bar{\mathbf{i}}_2$
 $[13]|1_a, 2_b, 3_c\rangle = |3_a, 2_b, 1_c\rangle$

Only relative position counts here!
 (Mock-Mach Principle!)

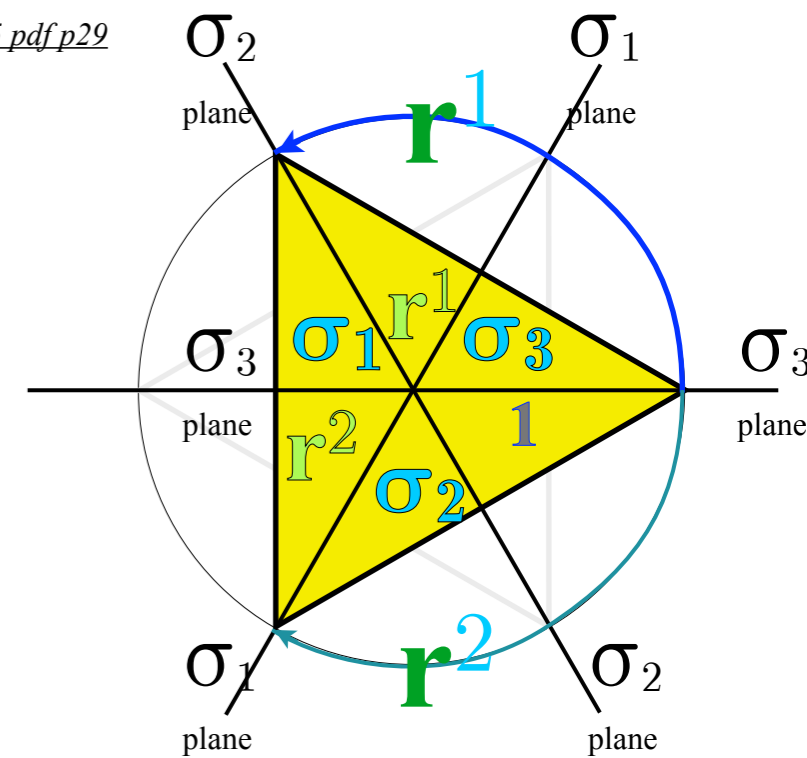

1	r^2	r	i_1	i_2	i_3
r	1	r^2	i_2	i_3	i_1
r^2	r	1	i_3	i_1	i_2
i_1	i_2	i_3	1	r^2	r
i_2	i_3	i_1	r	1	r^2
i_3	i_1	i_2	r^2	r	1

C_{3v} gg^\dagger form	1	r^2	r^1	σ_1	σ_2	σ_3
$(a)(b)(c) = 1$	1	r^2	r^1	σ_1	σ_2	σ_3
$(abc) = r^1$	r^1	1	r^2	σ_2	σ_3	σ_1
$(acb) = r^2$	r^2	r^1	1	σ_3	σ_1	σ_2
$(bc) = \sigma_1$	σ_1	σ_2	σ_3	1	r^2	r^1
$(ac) = \sigma_2$	σ_2	σ_3	σ_1	r^1	1	r^2
$(ab) = \sigma_3$	σ_3	σ_1	σ_2	r^2	r^1	1

Fig. 25.3.1 Relating D_3 and S_3 permutation operations

4.16.18 class 23: *Symmetry Principles for Advanced Atomic-Molecular-Optical-Physics* William G. Harter - University of Arkansas

$(S_n)^*(U(m))$ shell model of electrostatic quadrupole-quadrupole-e interactions

Marrying spin $s=1/2$ and orbital $\ell=1$ together: $U(3)\times U(2)$

The $\ell=1$ p -shell in a nutshell

$U(6)\supset U(3)\times U(2)$ approach: Coupling spin-orbit ($s=1/2, \ell=1$) tableaux

Introducing atomic spin-orbit state assembly formula

Slater determinants

p -shell Spin-orbit calculations (not finished)

Clebsch Gordan coefficients. (Rev. Mod. Phys. annual gift)

S_n projection for atomic spin and orbit states

Review of Mach-Mock (particle-state) principle

 Tableau P-operators on orbits (Yamououchi formula)

Tableau P-operators on spin

Fermi-Dirac-Pauli anti-symmetric p^3 -states

Boson operators and symmetric p^2 -states

Connecting to angular momentum

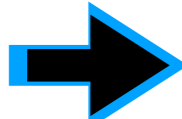
Projecting to angular momentum

S_n projection for atomic spin and orbit states

Dirac-ket-ket-ket product represents states 1, 2, 3 that variously occupy particles a , b , and c ,

$$|1,2,3\rangle \equiv |1\rangle_{particle-a} |2\rangle_{particle-b} |3\rangle_{particle-c} \equiv |1\rangle_a |2\rangle_b |3\rangle_c$$

S_n projection for atomic spin and orbit states

Dirac-ket-ket-ket product represents states 1, 2, 3 that variously occupy particles a , b , and c ,

$$|1,2,3\rangle \equiv |1\rangle_{particle-a} |2\rangle_{particle-b} |3\rangle_{particle-c} \equiv |1\rangle_a |2\rangle_b |3\rangle_c$$

Sub-tableaus $\begin{smallmatrix} \boxed{a} & \boxed{b} \end{smallmatrix}$ (or $\begin{smallmatrix} \boxed{a} \\ \boxed{b} \end{smallmatrix}$) label symmetry (anti-symmetry) by single row (or single column)

$$D^E[12] = \begin{array}{c} \begin{smallmatrix} \boxed{1} & \boxed{2} \\ \boxed{3} \end{smallmatrix} \\ \begin{smallmatrix} \boxed{1} & \boxed{3} \\ \boxed{2} \end{smallmatrix} \end{array} \left| \begin{array}{cc} +1 & 0 \\ 0 & -1 \end{array} \right.$$

$$D^E(ab) = \begin{array}{c} \begin{smallmatrix} \boxed{a} & \boxed{b} \\ \boxed{c} \end{smallmatrix} \\ \begin{smallmatrix} \boxed{a} & \boxed{c} \\ \boxed{b} \end{smallmatrix} \end{array} \left| \begin{array}{cc} +1 & 0 \\ 0 & -1 \end{array} \right.$$

S_n projection for atomic spin and orbit states: Tableau P-operators

Dirac-ket-ket-ket product represents states 1, 2, 3 that variously occupy particles $a, b,$ and $c,$

$$|1,2,3\rangle \equiv |1\rangle_{particle-a} |2\rangle_{particle-b} |3\rangle_{particle-c} \equiv |1\rangle_a |2\rangle_b |3\rangle_c$$

Sub-tableaus $\boxed{a|b}$ (or $\begin{smallmatrix} \boxed{a} \\ \boxed{b} \end{smallmatrix}$) label symmetry (anti-symmetry) by single row (or single column)

$$D^E[12] = \begin{array}{c} \boxed{1|2} \\ \boxed{3} \\ \boxed{1|3} \\ \boxed{2} \end{array} \left| \begin{array}{cc} +1 & 0 \\ 0 & -1 \end{array} \right. \quad D^E(ab) = \begin{array}{c} \boxed{a|b} \\ \boxed{c} \\ \boxed{a|c} \\ \boxed{b} \end{array} \left| \begin{array}{cc} +1 & 0 \\ 0 & -1 \end{array} \right.$$

Yamanouchi formula for irrep of bicycle operation $[n, n-1]$ i.e. $[23]$.

(following page)

$$D^E[23] = \begin{array}{c} \boxed{1|2} \\ \boxed{3} \\ \boxed{1|3} \\ \boxed{2} \end{array} \left| \begin{array}{cc} \frac{-1}{2} & \frac{\sqrt{3}}{2} \\ \frac{\sqrt{3}}{2} & \frac{+1}{2} \end{array} \right. \quad D^E(bc) = \begin{array}{c} \boxed{a|b} \\ \boxed{c} \\ \boxed{a|c} \\ \boxed{b} \end{array} \left| \begin{array}{cc} \frac{-1}{2} & \frac{\sqrt{3}}{2} \\ \frac{\sqrt{3}}{2} & \frac{+1}{2} \end{array} \right.$$

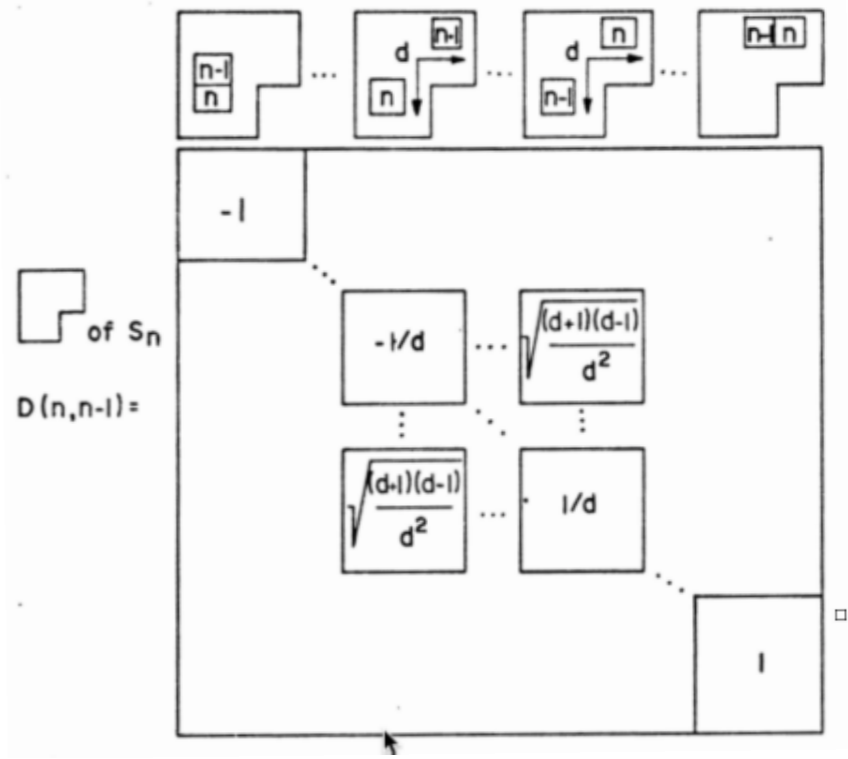

S_n projection for atomic spin and orbit states: Tableau P-operators

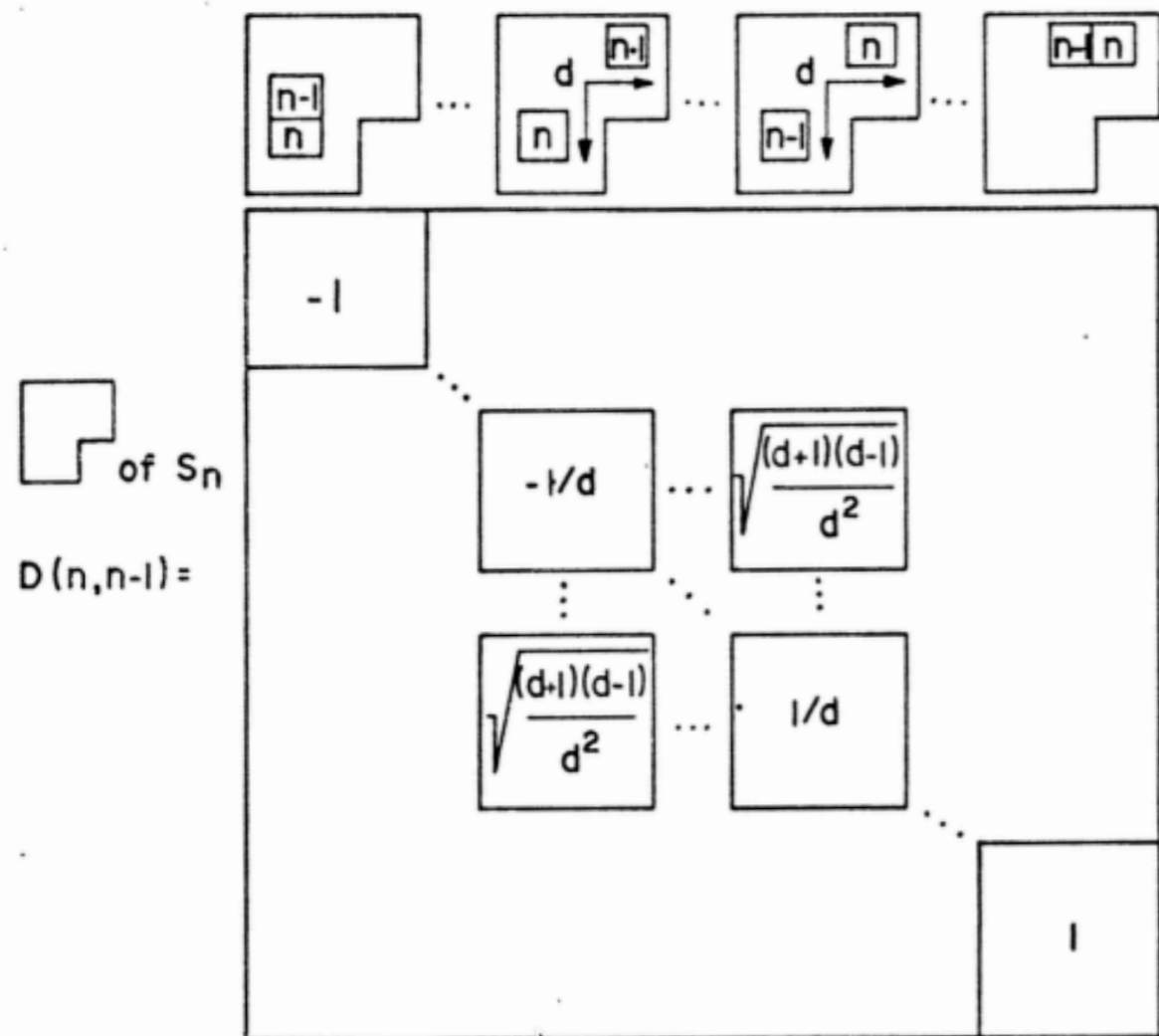

EXAMPLE:

1	2	3
4		
5		

1	2	4
3		
5		

1	2	5
3		
4		

1	3	4
2		
5		

1	3	5
2		
4		

1	4	5
2		
3		

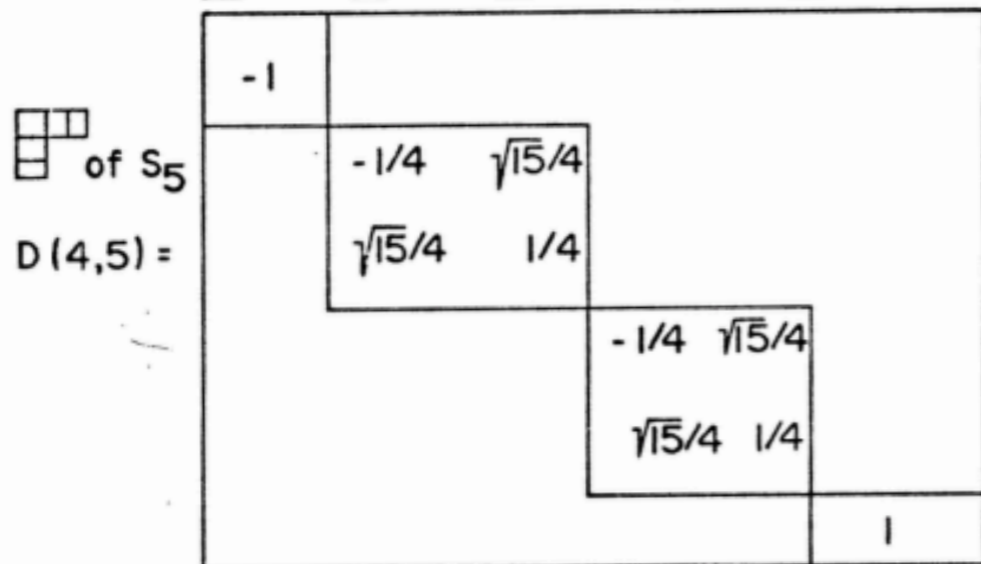

$$D_{(\sigma_2)}^E = D^{[2,1]}(bc) = \begin{matrix} \begin{matrix} ab \\ c \end{matrix} \\ \begin{matrix} ac \\ b \end{matrix} \end{matrix} \begin{pmatrix} -1/2 & \sqrt{3}/2 \\ \sqrt{3}/2 & 1/2 \end{pmatrix}$$

$$D^{[2,1]}(ab) = \begin{matrix} \begin{matrix} ab \\ c \end{matrix} \\ \begin{matrix} ac \\ b \end{matrix} \end{matrix} \begin{pmatrix} 1 & 0 \\ 0 & -1 \end{pmatrix}$$

*From unpublished Ch.10 for
Principles of Symmetry, Dynamics & Spectroscopy*

Fig. 10.1.2 Yamanouchi formulas for permutation operators.

Integer d is the "city block" distance between (n) and $(n-1)$ blocks, i.e., the minimum number of streets to be crossed when traveling from one to the other. Note that when numbers (n) and $(n-1)$ are ordered smaller above larger, the permutation is negative (anti-symmetric if $d=1$), and positive (symmetric if $d=1$) when the smaller number is left of the larger number. [The $(n-1)$ will never be above and left of (n) since that arrangement would be "non-standard."]

S_n projection for atomic spin and orbit states: Tableau P-operators

Dirac-ket-ket-ket product represents states 1, 2, 3 that variously occupy particles $a, b,$ and $c,$

$$|1,2,3\rangle \equiv |1\rangle_{particle-a} |2\rangle_{particle-b} |3\rangle_{particle-c} \equiv |1\rangle_a |2\rangle_b |3\rangle_c$$

Ssub-tableaus $\begin{smallmatrix} \boxed{a} \\ \boxed{b} \end{smallmatrix}$ (or $\begin{smallmatrix} \boxed{a} \\ \boxed{b} \end{smallmatrix}$) label symmetry (anti-symmetry) by single row (or single column)

$$D^E[12] = \begin{array}{c|cc} \begin{smallmatrix} \boxed{1} & \boxed{2} \\ \boxed{3} \end{smallmatrix} & +1 & 0 \\ \begin{smallmatrix} \boxed{1} & \boxed{3} \\ \boxed{2} \end{smallmatrix} & 0 & -1 \end{array} \quad D^E(ab) = \begin{array}{c|cc} \begin{smallmatrix} \boxed{a} & \boxed{b} \\ \boxed{c} \end{smallmatrix} & +1 & 0 \\ \begin{smallmatrix} \boxed{a} & \boxed{c} \\ \boxed{b} \end{smallmatrix} & 0 & -1 \end{array}$$

Yamanouchi formula for irrep of bicycle operation $[n, n-1]$ i.e. $[23]$.

(following page)

$$D^E[23] = \begin{array}{c|cc} \begin{smallmatrix} \boxed{1} & \boxed{2} \\ \boxed{3} \end{smallmatrix} & \frac{-1}{2} & \frac{\sqrt{3}}{2} \\ \begin{smallmatrix} \boxed{1} & \boxed{3} \\ \boxed{2} \end{smallmatrix} & \frac{\sqrt{3}}{2} & \frac{+1}{2} \end{array} \quad D^E(bc) = \begin{array}{c|cc} \begin{smallmatrix} \boxed{a} & \boxed{b} \\ \boxed{c} \end{smallmatrix} & \frac{-1}{2} & \frac{\sqrt{3}}{2} \\ \begin{smallmatrix} \boxed{a} & \boxed{c} \\ \boxed{b} \end{smallmatrix} & \frac{\sqrt{3}}{2} & \frac{+1}{2} \end{array}$$

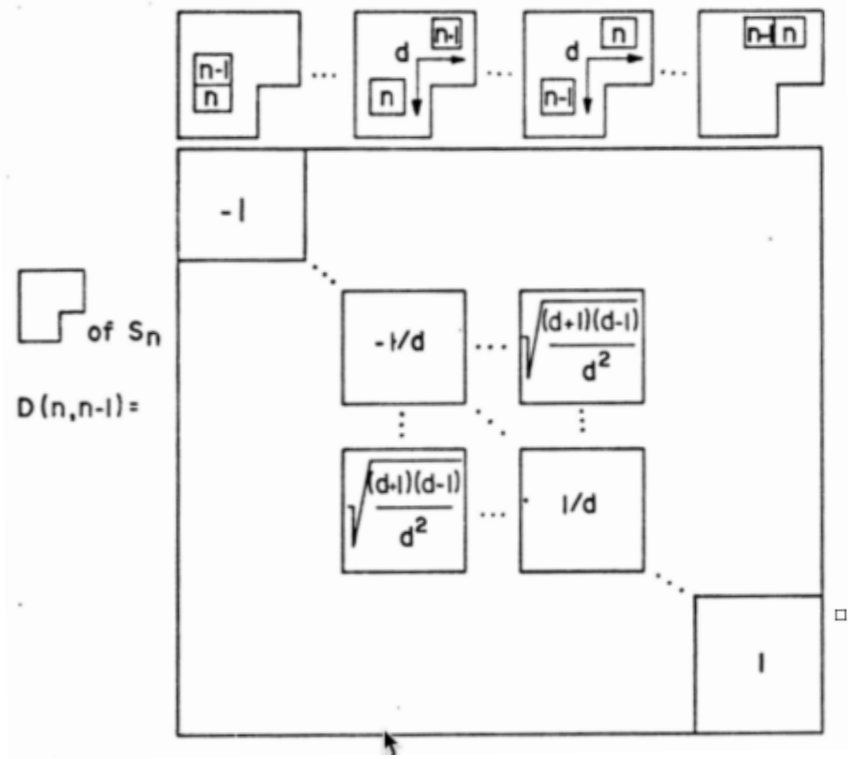

Gives complete set of permutation ireps and projectors.

$\mathbf{g} =$	$\mathbf{1} = (a)(b)(c)$	$\mathbf{r} = (abc)$	$\mathbf{r}^2 = (acb)$	$\mathbf{i}_1 = (bc)$	$\mathbf{i}_2 = (ac)$	$\mathbf{i}_3 = (ab)$
$D^{A_1}(\mathbf{g}) =$	1	1	1	1	1	1
$D^{A_2}(\mathbf{g}) =$	1	1	1	-1	-1	-1
$D^{E_1}_{x_2 y_2}(\mathbf{g}) =$	$\begin{pmatrix} 1 & 0 \\ 0 & 1 \end{pmatrix}$	$\begin{pmatrix} -1/2 & -\sqrt{3}/2 \\ \sqrt{3}/2 & -1/2 \end{pmatrix}$	$\begin{pmatrix} -1/2 & \sqrt{3}/2 \\ -\sqrt{3}/2 & -1/2 \end{pmatrix}$	$\begin{pmatrix} -1/2 & \sqrt{3}/2 \\ \sqrt{3}/2 & 1/2 \end{pmatrix}$	$\begin{pmatrix} -1/2 & -\sqrt{3}/2 \\ -\sqrt{3}/2 & 1/2 \end{pmatrix}$	$\begin{pmatrix} 1 & 0 \\ 0 & -1 \end{pmatrix}$

S_n projection for atomic spin and orbit states: Tableau P-operators

Dirac-ket-ket-ket product represents states 1, 2, 3 that variously occupy particles $a, b,$ and $c,$

$$|1,2,3\rangle \equiv |1\rangle_{particle-a} |2\rangle_{particle-b} |3\rangle_{particle-c} \equiv |1\rangle_a |2\rangle_b |3\rangle_c$$

Ssub-tableaus $\begin{smallmatrix} a & b \\ \hline \end{smallmatrix}$ (or $\begin{smallmatrix} a \\ b \end{smallmatrix}$) label symmetry (anti-symmetry) by single row (or single column)

$$D^E[12] = \begin{array}{c|cc} \begin{smallmatrix} 1 & 2 \\ \hline \end{smallmatrix} & +1 & 0 \\ \begin{smallmatrix} 3 \\ \hline \end{smallmatrix} & & \\ \begin{smallmatrix} 1 & 3 \\ \hline \end{smallmatrix} & 0 & -1 \\ \begin{smallmatrix} 2 \\ \hline \end{smallmatrix} & & \end{array} \quad D^E(ab) = \begin{array}{c|cc} \begin{smallmatrix} a & b \\ \hline \end{smallmatrix} & +1 & 0 \\ \begin{smallmatrix} c \\ \hline \end{smallmatrix} & & \\ \begin{smallmatrix} a & c \\ \hline \end{smallmatrix} & 0 & -1 \\ \begin{smallmatrix} b \\ \hline \end{smallmatrix} & & \end{array}$$

Yamanouchi formula for irrep of bicycle operation $[n, n-1]$ i.e. $[23]$.

$$D^E[23] = \begin{array}{c|cc} \begin{smallmatrix} 1 & 2 \\ \hline \end{smallmatrix} & \frac{-1}{2} & \frac{\sqrt{3}}{2} \\ \begin{smallmatrix} 3 \\ \hline \end{smallmatrix} & \frac{2}{2} & \frac{2}{2} \\ \begin{smallmatrix} 1 & 3 \\ \hline \end{smallmatrix} & \frac{\sqrt{3}}{2} & \frac{+1}{2} \\ \begin{smallmatrix} 2 \\ \hline \end{smallmatrix} & \frac{2}{2} & \frac{2}{2} \end{array} \quad D^E(bc) = \begin{array}{c|cc} \begin{smallmatrix} a & b \\ \hline \end{smallmatrix} & \frac{-1}{2} & \frac{\sqrt{3}}{2} \\ \begin{smallmatrix} c \\ \hline \end{smallmatrix} & \frac{2}{2} & \frac{2}{2} \\ \begin{smallmatrix} a & c \\ \hline \end{smallmatrix} & \frac{\sqrt{3}}{2} & \frac{+1}{2} \\ \begin{smallmatrix} b \\ \hline \end{smallmatrix} & \frac{2}{2} & \frac{2}{2} \end{array}$$

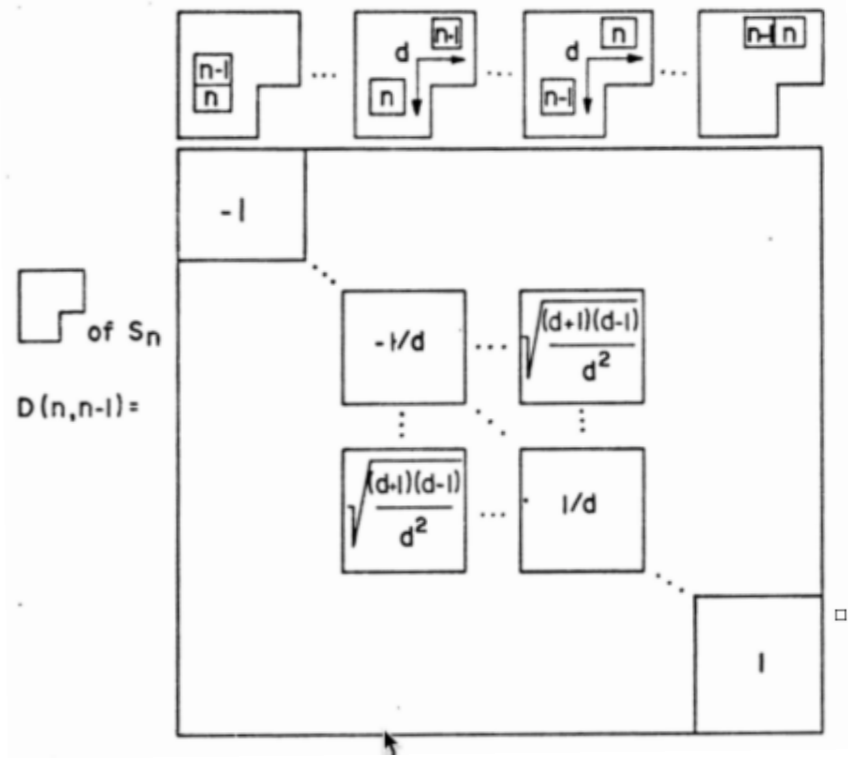

Gives complete set of permutation ireps and projectors. *(following page)*

$\mathbf{g} =$	$\mathbf{1} = (a)(b)(c)$	$\mathbf{r} = (abc)$	$\mathbf{r}^2 = (acb)$	$\mathbf{i}_1 = (bc)$	$\mathbf{i}_2 = (ac)$	$\mathbf{i}_3 = (ab)$
$D^{A_1}(\mathbf{g}) =$	1	1	1	1	1	1
$D^{A_2}(\mathbf{g}) =$	1	1	1	-1	-1	-1
$D^{E_1}_{x_2 y_2}(\mathbf{g}) =$	$\begin{pmatrix} 1 & 0 \\ 0 & 1 \end{pmatrix}$	$\begin{pmatrix} -1/2 & -\sqrt{3}/2 \\ \sqrt{3}/2 & -1/2 \end{pmatrix}$	$\begin{pmatrix} -1/2 & \sqrt{3}/2 \\ -\sqrt{3}/2 & -1/2 \end{pmatrix}$	$\begin{pmatrix} -1/2 & \sqrt{3}/2 \\ \sqrt{3}/2 & 1/2 \end{pmatrix}$	$\begin{pmatrix} -1/2 & -\sqrt{3}/2 \\ -\sqrt{3}/2 & 1/2 \end{pmatrix}$	$\begin{pmatrix} 1 & 0 \\ 0 & -1 \end{pmatrix}$

$$\mathbf{P}_{j,k}^{[\mu]} |1\rangle_{\text{norm}} = \sqrt{\frac{\ell^{[\mu]}}{O_G}} \left(D_{j,k}^{[\mu]}(1) |1\rangle + D(r) |\mathbf{r}\rangle + D(r^2) |\mathbf{r}^2\rangle + D(i_1) |\mathbf{i}_1\rangle + D(i_2) |\mathbf{i}_2\rangle + D(i_3) |\mathbf{i}_3\rangle \right)$$

S_n projection for atomic spin and orbit states: Tableau P-operators

$$\mathbf{P}_{j,k}^{[\mu]} |1\rangle_{\text{norm}} = \sqrt{\frac{\ell^{[\mu]}}{O_G}} \left(D_{j,k}^{[\mu]}(1)|1\rangle + D(r)|\mathbf{r}\rangle + D(r^2)|\mathbf{r}^2\rangle + D(i_1)|\mathbf{i}_1\rangle + D(i_2)|\mathbf{i}_2\rangle + D(i_3)|\mathbf{i}_3\rangle \right)$$

$$\left| \begin{array}{|c|c|c|} \hline \square & \square & \square \\ \hline 1 & 2 & 3 \\ \hline \end{array} \right\rangle = \mathbf{P}_{\begin{array}{|c|c|c|} \hline a & b & c \\ \hline 1 & 2 & 3 \\ \hline \end{array}}^{\begin{array}{|c|c|c|} \hline \square & \square & \square \\ \hline \square & \square & \square \\ \hline \end{array}} |1,2,3\rangle \sqrt{6} = \left(\frac{|1,2,3\rangle + |2,3,1\rangle + |3,1,2\rangle + |1,3,2\rangle + |3,2,1\rangle + |2,1,3\rangle}{\sqrt{6}} \right)$$

$$\left| \begin{array}{|c|} \hline \square \\ \hline \square \\ \hline 1 \\ \hline 2 \\ \hline 3 \\ \hline \end{array} \right\rangle = \mathbf{P}_{\begin{array}{|c|} \hline a \\ \hline b \\ \hline c \\ \hline \end{array}}^{\begin{array}{|c|} \hline \square \\ \hline \square \\ \hline 1 \\ \hline 2 \\ \hline 3 \\ \hline \end{array}} |1,2,3\rangle \sqrt{6} = \left(\frac{|1,2,3\rangle + |2,3,1\rangle + |3,1,2\rangle + (-1)|1,3,2\rangle + (-1)|3,2,1\rangle + (-1)|2,1,3\rangle}{\sqrt{6}} \right)$$

$$\left| \begin{array}{|c|c|} \hline \square & \square \\ \hline a & b \\ \hline c & 1 \\ \hline c & 2 \\ \hline \end{array} \right\rangle = \mathbf{P}_{\begin{array}{|c|c|} \hline a & b \\ \hline c & c \\ \hline \end{array}}^{\begin{array}{|c|c|} \hline \square & \square \\ \hline a & b \\ \hline c & c \\ \hline \end{array}} |1,2,3\rangle \sqrt{3} = \left(\frac{2|1,2,3\rangle + (-1)|2,3,1\rangle + (-1)|3,1,2\rangle + (-1)|1,3,2\rangle + (-1)|3,2,1\rangle + 2|2,1,3\rangle}{2\sqrt{3}} \right)$$

$$\left| \begin{array}{|c|c|} \hline \square & \square \\ \hline a & c \\ \hline b & 1 \\ \hline b & 2 \\ \hline \end{array} \right\rangle = \mathbf{P}_{\begin{array}{|c|c|} \hline a & c \\ \hline b & c \\ \hline \end{array}}^{\begin{array}{|c|c|} \hline \square & \square \\ \hline a & b \\ \hline c & c \\ \hline \end{array}} |1,2,3\rangle \sqrt{3} = \left(\frac{0|1,2,3\rangle + (+1)|2,3,1\rangle + (-1)|3,1,2\rangle + (+1)|1,3,2\rangle + (-1)|3,2,1\rangle + 0|2,1,3\rangle}{2} \right)$$

$$\left| \begin{array}{|c|c|} \hline \square & \square \\ \hline a & b \\ \hline c & 1 \\ \hline c & 2 \\ \hline \end{array} \right\rangle = \mathbf{P}_{\begin{array}{|c|c|} \hline a & b \\ \hline c & b \\ \hline \end{array}}^{\begin{array}{|c|c|} \hline \square & \square \\ \hline a & c \\ \hline c & c \\ \hline \end{array}} |1,2,3\rangle \sqrt{3} = \left(\frac{0|1,2,3\rangle + (-1)|2,3,1\rangle + (+1)|3,1,2\rangle + (+1)|1,3,2\rangle + (-1)|3,2,1\rangle + 0|2,1,3\rangle}{2} \right)$$

$$\left| \begin{array}{|c|c|} \hline \square & \square \\ \hline a & c \\ \hline b & 1 \\ \hline b & 2 \\ \hline \end{array} \right\rangle = \mathbf{P}_{\begin{array}{|c|c|} \hline a & c \\ \hline b & b \\ \hline \end{array}}^{\begin{array}{|c|c|} \hline \square & \square \\ \hline a & c \\ \hline c & c \\ \hline \end{array}} |1,2,3\rangle \sqrt{3} = \left(\frac{2|1,2,3\rangle + (-1)|2,3,1\rangle + (-1)|3,1,2\rangle + (+1)|1,3,2\rangle + (+1)|3,2,1\rangle - 2|2,1,3\rangle}{2} \right)$$

particle (abc) labels [j] of $\mathbf{P}_{[j](k)}$ projectors face left

state (123) labels [k] face the state $|1,2,3\rangle$ on the right.

4.16.18 class 23: *Symmetry Principles for Advanced Atomic-Molecular-Optical-Physics* William G. Harter - University of Arkansas

$(S_n)^*(U(m))$ shell model of electrostatic quadrupole-quadrupole-e interactions

Marrying spin $s=1/2$ and orbital $\ell=1$ together: $U(3)\times U(2)$

The $\ell=1$ p -shell in a nutshell

$U(6)\supset U(3)\times U(2)$ approach: Coupling spin-orbit ($s=1/2$, $\ell=1$) tableaus

Introducing atomic spin-orbit state assembly formula

Slater determinants

p -shell Spin-orbit calculations (not finished)

Clebsch Gordan coefficients. (Rev. Mod. Phys. annual gift)

S_n projection for atomic spin and orbit states

Review of Mach-Mock (particle-state) principle

Tableau P-operators on orbits (Yamououchi formula)



Tableau P-operators on spin

Fermi-Dirac-Pauli anti-symmetric p^3 -states

Boson operators and symmetric p^2 -states

Connecting to angular momentum

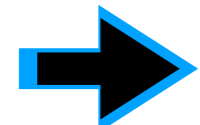
Projecting to angular momentum

S_n projection for atomic spin and orbit states: Tableau P-operators on spin

Projectors are applied to 3-electron spin states of which there are eight ($2^3=8$).

First is a single symmetric A_1 projection $\mathbf{P}^{A_1} = \mathbf{P}^{\square\square\square}$ of state $|\uparrow\uparrow\uparrow\rangle$

$$\left| \begin{array}{c} \square\square\square \\ \uparrow\uparrow\uparrow \end{array} \right\rangle_{3/2} = \mathbf{P}^{\square\square\square}_{\substack{a\ b\ c \\ \uparrow\uparrow\uparrow}} |\uparrow\uparrow\uparrow\rangle = |\uparrow\uparrow\uparrow\rangle \quad (\text{Note } \mathbf{P}^{E_1} = \mathbf{P}^{\square\square} \text{ acting on } |\uparrow\uparrow\uparrow\rangle \text{ is zero.})$$

S_n projection for atomic spin and orbit states: Tableau P-operators on spin

Projectors are applied to 3-electron spin states of which there are eight ($2^3=8$).

First is a single symmetric A_1 projection $\mathbf{P}^{A_1} = \mathbf{P}^{\square\square\square}$ of state $|\uparrow\uparrow\uparrow\rangle$

$$\left| \begin{array}{c} \square\square\square \\ \uparrow\uparrow\uparrow \end{array} \right\rangle_{3/2} = \mathbf{P}^{\square\square\square}_{\begin{array}{c} a \\ b \\ c \end{array} \begin{array}{c} \uparrow \\ \uparrow \\ \uparrow \end{array}} |\uparrow\uparrow\uparrow\rangle = |\uparrow\uparrow\uparrow\rangle \quad (\text{Note } \mathbf{P}^{E_1} = \mathbf{P}^{\square\square} \text{ acting on } |\uparrow\uparrow\uparrow\rangle \text{ is zero.})$$

Anti symmetric A_2 projection fails on *all* spin-1/2 states

$$\left| \begin{array}{c} \square \\ \square \\ \uparrow \\ \uparrow \\ \uparrow \end{array} \right\rangle = \mathbf{P}^{\square\square\square}_{\begin{array}{c} a \\ b \\ c \end{array} \begin{array}{c} \uparrow \\ \uparrow \\ \uparrow \end{array}} \left| \begin{array}{c} \square \\ \square \\ \uparrow \\ \uparrow \\ \uparrow \end{array} \right\rangle = 0 \quad (\text{Does not exist}), \quad \left| \begin{array}{c} \square \\ \square \\ \uparrow \\ \uparrow \\ \downarrow \end{array} \right\rangle = \mathbf{P}^{\square\square\square}_{\begin{array}{c} a \\ b \\ c \end{array} \begin{array}{c} \uparrow \\ \uparrow \\ \downarrow \end{array}} \left| \begin{array}{c} \square \\ \square \\ \uparrow \\ \uparrow \\ \downarrow \end{array} \right\rangle = 0 \quad (\text{Does not exist}), \dots \text{etc.}$$

Symmetric $\mathbf{P}^{A_1} = \mathbf{P}^{\square\square\square}$ or para-symmetric $\mathbf{P}^{E_1} = \mathbf{P}^{\square\square}$ projection of $|\uparrow\uparrow\downarrow\rangle$ and $|\uparrow\downarrow\downarrow\rangle$ give $\left| \begin{array}{c} S=3/2 \\ M=\pm 1/2 \end{array} \right\rangle$ or $\left| \begin{array}{c} S=1/2 \\ M=\pm 1/2 \end{array} \right\rangle$.

S_n projection for atomic spin and orbit states: Tableau P-operators on spin

Projectors are applied to 3-electron spin states of which there are eight ($2^3=8$).

First is a single symmetric A_1 projection $\mathbf{P}^{A_1} = \mathbf{P}^{\square\square\square}$ of state $|\uparrow\uparrow\uparrow\rangle$
 $\left| \begin{array}{c} \square\square\square \\ \uparrow\uparrow\uparrow \end{array} \right\rangle_{3/2} = \mathbf{P}^{\square\square\square}_{\begin{array}{c} a \\ b \\ c \end{array} \begin{array}{c} \uparrow\uparrow\uparrow \end{array}} |\uparrow\uparrow\uparrow\rangle = |\uparrow\uparrow\uparrow\rangle$ (Note $\mathbf{P}^{E_1} = \mathbf{P}^{\square\square}$ acting on $|\uparrow\uparrow\uparrow\rangle$ is zero.)

Anti symmetric A_2 projection fails on *all* spin-1/2 states

$$\left| \begin{array}{c} \square \\ \square \\ \uparrow \\ \uparrow \\ \uparrow \end{array} \right\rangle = \mathbf{P}^{\square\square\square}_{\begin{array}{c} a \\ b \\ c \end{array} \begin{array}{c} \uparrow \\ \uparrow \\ \uparrow \end{array}} \left| \begin{array}{c} \square \\ \square \\ \square \end{array} \right\rangle_{3/2} = 0 \text{ (Does not exist), } \left| \begin{array}{c} \square \\ \square \\ \uparrow \\ \uparrow \\ \downarrow \end{array} \right\rangle = \mathbf{P}^{\square\square\square}_{\begin{array}{c} a \\ b \\ c \end{array} \begin{array}{c} \uparrow \\ \uparrow \\ \downarrow \end{array}} \left| \begin{array}{c} \square \\ \square \\ \square \end{array} \right\rangle_{3/2} = 0 \text{ (Does not exist),...etc.}$$

Symmetric $\mathbf{P}^{A_1} = \mathbf{P}^{\square\square\square}$ or para-symmetric $\mathbf{P}^{E_1} = \mathbf{P}^{\square\square}$ projection of $|\uparrow\uparrow\downarrow\rangle$ and $|\uparrow\downarrow\downarrow\rangle$ give $\left| \begin{array}{c} \square\square\square \\ \uparrow\uparrow\downarrow \end{array} \right\rangle_{3/2}$ or $\left| \begin{array}{c} \square\square \\ \uparrow\uparrow\downarrow \end{array} \right\rangle_{1/2}$.

$$\left| \begin{array}{c} \square\square\square \\ \uparrow\uparrow\downarrow \end{array} \right\rangle_{3/2} = \mathbf{P}^{\square\square\square}_{\begin{array}{c} a \\ b \\ c \end{array} \begin{array}{c} a \\ b \\ c \end{array}} |\uparrow, \uparrow, \downarrow\rangle \sqrt{3} = \left(\frac{|\uparrow, \uparrow, \downarrow\rangle + |\uparrow, \downarrow, \uparrow\rangle + |\downarrow, \uparrow, \uparrow\rangle + |\uparrow, \downarrow, \uparrow\rangle + |\downarrow, \uparrow, \uparrow\rangle + |\uparrow, \uparrow, \downarrow\rangle}{\sqrt{6}} \right) = \left(\frac{|\uparrow, \uparrow, \downarrow\rangle + |\uparrow, \downarrow, \uparrow\rangle + |\downarrow, \uparrow, \uparrow\rangle}{\sqrt{3}} \right)$$

$$\left| \begin{array}{c} \square\square \\ \uparrow\uparrow\downarrow \end{array} \right\rangle_{1/2} = \mathbf{P}^{\square\square}_{\begin{array}{c} a \\ b \\ c \end{array} \begin{array}{c} a \\ b \\ c \end{array}} |\uparrow, \uparrow, \downarrow\rangle \sqrt{3} = \left(\frac{2|\uparrow, \uparrow, \downarrow\rangle + (-1)|\uparrow, \downarrow, \uparrow\rangle + (-1)|\downarrow, \uparrow, \uparrow\rangle + (-1)|\uparrow, \downarrow, \uparrow\rangle + (-1)|\downarrow, \uparrow, \uparrow\rangle + 2|\uparrow, \uparrow, \downarrow\rangle}{2\sqrt{6}} \right) = \left(\frac{2|\uparrow, \uparrow, \downarrow\rangle + (-1)|\uparrow, \downarrow, \uparrow\rangle + (-1)|\downarrow, \uparrow, \uparrow\rangle}{\sqrt{6}} \right)$$

$$\left| \begin{array}{c} \square\square \\ \uparrow\downarrow\downarrow \end{array} \right\rangle_{1/2} = \mathbf{P}^{\square\square}_{\begin{array}{c} a \\ b \\ c \end{array} \begin{array}{c} a \\ b \\ c \end{array}} |\uparrow, \uparrow, \downarrow\rangle \sqrt{3} = \left(\frac{0|\uparrow, \uparrow, \downarrow\rangle + (+1)|\uparrow, \downarrow, \uparrow\rangle + (-1)|\downarrow, \uparrow, \uparrow\rangle + (+1)|\uparrow, \downarrow, \uparrow\rangle + (-1)|\downarrow, \uparrow, \uparrow\rangle + 0|\uparrow, \uparrow, \downarrow\rangle}{2\sqrt{2}} \right) = \left(\frac{(+1)|\uparrow, \downarrow, \uparrow\rangle + (-1)|\downarrow, \uparrow, \uparrow\rangle}{\sqrt{2}} \right)$$

The latter make a permutation doublet.

There are two spin- $S=1/2$ states $\left| \begin{array}{c} \square\square \\ \uparrow\uparrow\downarrow \end{array} \right\rangle_{1/2}$ but only one spin- $S=3/2$ state $\left| \begin{array}{c} \square\square\square \\ \uparrow\uparrow\downarrow \end{array} \right\rangle_{3/2}$ have z-component $M=+1/2$.

S_n projection for atomic spin and orbit states: Tableau P-operators on spin

Projectors are applied to 3-electron spin states of which there are eight ($2^3=8$).

First is a single symmetric A_1 projection $\mathbf{P}^{A_1} = \mathbf{P}^{\square\square\square}$ of state $|\uparrow\uparrow\uparrow\rangle$

$$\left| \begin{array}{c} \square\square\square \\ \uparrow\uparrow\uparrow \end{array} \right\rangle_{3/2} = \mathbf{P}^{\begin{array}{c} \square\square\square \\ a\ b\ c \end{array}} \left| \uparrow\uparrow\uparrow \right\rangle = \left| \uparrow\uparrow\uparrow \right\rangle \quad (\text{Note } \mathbf{P}^{E_1} = \mathbf{P}^{\begin{array}{c} \square \\ \square \end{array}} \text{ acting on } |\uparrow\uparrow\uparrow\rangle \text{ is zero.})$$

Anti symmetric A_2 projection fails on *all* spin-1/2 states

$$\left| \begin{array}{c} \square \\ \square \\ \square \end{array} \right\rangle = \mathbf{P}^{\begin{array}{c} \square \\ a \\ b \\ c \end{array}} \left| \uparrow, \uparrow, \uparrow \right\rangle = 0 \quad (\text{Does not exist}), \quad \left| \begin{array}{c} \square \\ \square \\ \square \end{array} \right\rangle = \mathbf{P}^{\begin{array}{c} \square \\ a \\ b \\ c \end{array}} \left| \uparrow, \uparrow, \downarrow \right\rangle = 0 \quad (\text{Does not exist}), \dots \text{etc.}$$

Symmetric $\mathbf{P}^{A_1} = \mathbf{P}^{\square\square\square}$ and para-symmetric $\mathbf{P}^{E_1} = \mathbf{P}^{\begin{array}{c} \square \\ \square \end{array}}$ projection of $|\uparrow\uparrow\downarrow\rangle$ and $|\uparrow\downarrow\downarrow\rangle$ give $\left| \begin{array}{c} \square\square\square \\ \uparrow\uparrow\downarrow \end{array} \right\rangle_{3/2}$ and $\left| \begin{array}{c} \square\square \\ a\ b \\ c \end{array} \right\rangle_{1/2}$.

$$\left| \begin{array}{c} \square\square\square \\ \uparrow\uparrow\downarrow \end{array} \right\rangle_{3/2} = \mathbf{P}^{\begin{array}{c} \square\square\square \\ a\ b\ c \end{array}} \left| \uparrow, \uparrow, \downarrow \right\rangle \sqrt{3} = \left(\frac{|\uparrow, \uparrow, \downarrow\rangle + |\uparrow, \downarrow, \uparrow\rangle + |\downarrow, \uparrow, \uparrow\rangle + |\uparrow, \downarrow, \uparrow\rangle + |\downarrow, \uparrow, \uparrow\rangle + |\uparrow, \uparrow, \downarrow\rangle}{\sqrt{6}} \right) = \left(\frac{|\uparrow, \uparrow, \downarrow\rangle + |\uparrow, \downarrow, \uparrow\rangle + |\downarrow, \uparrow, \uparrow\rangle}{\sqrt{3}} \right)$$

$$\left| \begin{array}{c} \square\square \\ a\ b \\ c \end{array} \right\rangle_{1/2} = \mathbf{P}^{\begin{array}{c} \square\square \\ a\ b \\ c \end{array}} \left| \uparrow, \uparrow, \downarrow \right\rangle \sqrt{3} = \left(\frac{2|\uparrow, \uparrow, \downarrow\rangle + (-1)|\uparrow, \downarrow, \uparrow\rangle + (-1)|\downarrow, \uparrow, \uparrow\rangle + (-1)|\uparrow, \downarrow, \uparrow\rangle + (-1)|\downarrow, \uparrow, \uparrow\rangle + 2|\uparrow, \uparrow, \downarrow\rangle}{2\sqrt{6}} \right) = \left(\frac{2|\uparrow, \uparrow, \downarrow\rangle + (-1)|\uparrow, \downarrow, \uparrow\rangle + (-1)|\downarrow, \uparrow, \uparrow\rangle}{\sqrt{6}} \right)$$

$$\left| \begin{array}{c} \square\square \\ a\ c \\ b \end{array} \right\rangle_{1/2} = \mathbf{P}^{\begin{array}{c} \square\square \\ a\ c \\ b \end{array}} \left| \uparrow, \uparrow, \downarrow \right\rangle \sqrt{3} = \left(\frac{0|\uparrow, \uparrow, \downarrow\rangle + (+1)|\uparrow, \downarrow, \uparrow\rangle + (-1)|\downarrow, \uparrow, \uparrow\rangle + (+1)|\uparrow, \downarrow, \uparrow\rangle + (-1)|\downarrow, \uparrow, \uparrow\rangle + 0|\uparrow, \uparrow, \downarrow\rangle}{2\sqrt{2}} \right) = \left(\frac{(+1)|\uparrow, \downarrow, \uparrow\rangle + (-1)|\downarrow, \uparrow, \uparrow\rangle}{\sqrt{2}} \right)$$

The latter make a permutation doublet.

There are two spin- $S=1/2$ states $\left| \begin{array}{c} \square\square \\ a\ b \\ c \end{array} \right\rangle_{1/2}$ but only one spin- $S=3/2$ state $\left| \begin{array}{c} \square\square\square \\ \uparrow\uparrow\downarrow \end{array} \right\rangle_{3/2}$ have z-component $M=+1/2$.

All 3 states project from $|\uparrow\uparrow\downarrow\rangle$. The left [j]-labels of the last two make a particle doublet $\left\{ \begin{array}{c} a\ b \\ c \end{array} \right\}$.

S_n projection for atomic spin and orbit states: Tableau P-operators on spin

Symmetric $\mathbf{P}^{A_1} = \mathbf{P}^{\square\square\square}$ and para-symmetric $\mathbf{P}^{E_1} = \mathbf{P}^{\square\square}$ projection of $|\uparrow\uparrow\downarrow\rangle$ and $|\uparrow\downarrow\downarrow\rangle$ give $\left| \begin{smallmatrix} S=3/2 \\ M=\pm 1/2 \end{smallmatrix} \right\rangle$ and $\left| \begin{smallmatrix} S=1/2 \\ M=\pm 1/2 \end{smallmatrix} \right\rangle$.

$$\left| \begin{smallmatrix} \square\square\square \\ \uparrow\uparrow\downarrow \end{smallmatrix} \begin{smallmatrix} 3/2 \\ 1/2 \end{smallmatrix} \right\rangle = \mathbf{P}^{\square\square\square}_{\begin{smallmatrix} a & b & c \\ a & b & c \end{smallmatrix}} |\uparrow, \uparrow, \downarrow\rangle \sqrt{3} = \left(\frac{|\uparrow, \uparrow, \downarrow\rangle + |\uparrow, \downarrow, \uparrow\rangle + |\downarrow, \uparrow, \uparrow\rangle + |\uparrow, \downarrow, \uparrow\rangle + |\downarrow, \uparrow, \uparrow\rangle + |\uparrow, \uparrow, \downarrow\rangle}{\sqrt{6}} \right) = \left(\frac{|\uparrow, \uparrow, \downarrow\rangle + |\uparrow, \downarrow, \uparrow\rangle + |\downarrow, \uparrow, \uparrow\rangle}{\sqrt{3}} \right)$$

$$\left| \begin{smallmatrix} \square\square \\ a & b \\ c \end{smallmatrix} \begin{smallmatrix} \uparrow\uparrow \\ \uparrow\downarrow \end{smallmatrix} \begin{smallmatrix} 1/2 \\ 1/2 \end{smallmatrix} \right\rangle = \mathbf{P}^{\square\square}_{\begin{smallmatrix} a & b \\ c & c \end{smallmatrix}} |\uparrow, \uparrow, \downarrow\rangle \sqrt{\frac{3}{2}} = \left(\frac{2|\uparrow, \uparrow, \downarrow\rangle + (-1)|\uparrow, \downarrow, \uparrow\rangle + (-1)|\downarrow, \uparrow, \uparrow\rangle + (-1)|\uparrow, \downarrow, \uparrow\rangle + (-1)|\downarrow, \uparrow, \uparrow\rangle + 2|\uparrow, \uparrow, \downarrow\rangle}{2\sqrt{6}} \right) = \left(\frac{2|\uparrow, \uparrow, \downarrow\rangle + (-1)|\uparrow, \downarrow, \uparrow\rangle + (-1)|\downarrow, \uparrow, \uparrow\rangle}{\sqrt{6}} \right)$$

$$\left| \begin{smallmatrix} \square\square \\ a & c \\ b \end{smallmatrix} \begin{smallmatrix} \uparrow\uparrow \\ \uparrow\downarrow \end{smallmatrix} \begin{smallmatrix} 1/2 \\ 1/2 \end{smallmatrix} \right\rangle = \mathbf{P}^{\square\square}_{\begin{smallmatrix} a & c \\ b & c \end{smallmatrix}} |\uparrow, \uparrow, \downarrow\rangle \sqrt{\frac{3}{2}} = \left(\frac{0|\uparrow, \uparrow, \downarrow\rangle + (+1)|\uparrow, \downarrow, \uparrow\rangle + (-1)|\downarrow, \uparrow, \uparrow\rangle + (+1)|\uparrow, \downarrow, \uparrow\rangle + (-1)|\downarrow, \uparrow, \uparrow\rangle + 0|\uparrow, \uparrow, \downarrow\rangle}{2\sqrt{2}} \right) = \left(\frac{(+1)|\uparrow, \downarrow, \uparrow\rangle + (-1)|\downarrow, \uparrow, \uparrow\rangle}{\sqrt{2}} \right)$$

The latter make a permutation doublet.

There are two spin- $S=1/2$ states $\left| \begin{smallmatrix} S=1/2 \\ M=\pm 1/2 \end{smallmatrix} \right\rangle$ but only one spin- $S=3/2$ state $\left| \begin{smallmatrix} S=3/2 \\ M=\pm 1/2 \end{smallmatrix} \right\rangle$ have z-component $M=+1/2$.

S_n projection for atomic spin and orbit states (Top 3 lines moved up.)

Symmetric $\mathbf{P}^{A_1} = \mathbf{P}^{\square\square\square}$ and para-symmetric $\mathbf{P}^{E_1} = \mathbf{P}^{\square\square}$ projection of $|\uparrow\uparrow\downarrow\rangle$ and $|\uparrow\downarrow\downarrow\rangle$ give $\left| \begin{smallmatrix} S=3/2 \\ M=\pm 1/2 \end{smallmatrix} \right\rangle$ and $\left| \begin{smallmatrix} S=1/2 \\ M=\pm 1/2 \end{smallmatrix} \right\rangle$.

$$\left| \begin{smallmatrix} \square\square\square \\ \uparrow\uparrow\downarrow \\ 3/2 \\ 1/2 \end{smallmatrix} \right\rangle = \mathbf{P}^{\square\square\square}_{\begin{smallmatrix} \square\square\square \\ abc \\ abc \end{smallmatrix}} |\uparrow, \uparrow, \downarrow\rangle \sqrt{3} = \left(\frac{|\uparrow, \uparrow, \downarrow\rangle + |\uparrow, \downarrow, \uparrow\rangle + |\downarrow, \uparrow, \uparrow\rangle + |\uparrow, \downarrow, \uparrow\rangle + |\downarrow, \uparrow, \uparrow\rangle + |\uparrow, \uparrow, \downarrow\rangle}{\sqrt{6}} \right) = \left(\frac{|\uparrow, \uparrow, \downarrow\rangle + |\uparrow, \downarrow, \uparrow\rangle + |\downarrow, \uparrow, \uparrow\rangle}{\sqrt{3}} \right)$$

$$\left| \begin{smallmatrix} \square\square \\ \square \\ \square \\ \square \\ abc \\ \uparrow\uparrow \\ \downarrow \\ 1/2 \\ 1/2 \end{smallmatrix} \right\rangle = \mathbf{P}^{\square\square}_{\begin{smallmatrix} \square\square \\ abc \\ abc \end{smallmatrix}} |\uparrow, \uparrow, \downarrow\rangle \sqrt{\frac{3}{2}} = \left(\frac{2|\uparrow, \uparrow, \downarrow\rangle + (-1)|\uparrow, \downarrow, \uparrow\rangle + (-1)|\downarrow, \uparrow, \uparrow\rangle + (-1)|\uparrow, \downarrow, \uparrow\rangle + (-1)|\downarrow, \uparrow, \uparrow\rangle + 2|\uparrow, \uparrow, \downarrow\rangle}{2\sqrt{6}} \right) = \left(\frac{2|\uparrow, \uparrow, \downarrow\rangle + (-1)|\uparrow, \downarrow, \uparrow\rangle + (-1)|\downarrow, \uparrow, \uparrow\rangle}{\sqrt{6}} \right)$$

$$\left| \begin{smallmatrix} \square\square \\ \square \\ \square \\ \square \\ abc \\ \uparrow\uparrow \\ \downarrow \\ 1/2 \\ 1/2 \end{smallmatrix} \right\rangle = \mathbf{P}^{\square\square}_{\begin{smallmatrix} \square\square \\ abc \\ abc \end{smallmatrix}} |\uparrow, \uparrow, \downarrow\rangle \sqrt{\frac{3}{2}} = \left(\frac{0|\uparrow, \uparrow, \downarrow\rangle + (+1)|\uparrow, \downarrow, \uparrow\rangle + (-1)|\downarrow, \uparrow, \uparrow\rangle + (+1)|\uparrow, \downarrow, \uparrow\rangle + (-1)|\downarrow, \uparrow, \uparrow\rangle + 0|\uparrow, \uparrow, \downarrow\rangle}{2\sqrt{2}} \right) = \left(\frac{(+1)|\uparrow, \downarrow, \uparrow\rangle + (-1)|\downarrow, \uparrow, \uparrow\rangle}{\sqrt{2}} \right)$$

The latter make a permutation doublet.

There are two spin- $S=1/2$ states $\left| \begin{smallmatrix} S=1/2 \\ M=\pm 1/2 \end{smallmatrix} \right\rangle$ but only one spin- $S=3/2$ state $\left| \begin{smallmatrix} S=3/2 \\ M=\pm 1/2 \end{smallmatrix} \right\rangle$ have z-component $M=+1/2$.

All 3 states project from $|\uparrow\uparrow\downarrow\rangle$. The left [j]-labels of the last two make a particle doublet $\left\{ \begin{smallmatrix} \square\square \\ \square \\ abc \\ \uparrow\uparrow \\ \downarrow \\ 1/2 \\ 1/2 \end{smallmatrix} \right\}$.

S_n projection for atomic spin and orbit states: Tableau P-operators on spin

Symmetric $\mathbf{P}^{A_1} = \mathbf{P}^{\square\square\square}$ and para-symmetric $\mathbf{P}^{E_1} = \mathbf{P}^{\square\square}$ projection of $|\uparrow\uparrow\downarrow\rangle$ and $|\uparrow\downarrow\downarrow\rangle$ give $\left| \begin{smallmatrix} S=3/2 \\ M=\pm 1/2 \end{smallmatrix} \right\rangle$ and $\left| \begin{smallmatrix} S=1/2 \\ M=\pm 1/2 \end{smallmatrix} \right\rangle$.

$$\left| \begin{smallmatrix} \square\square\square & 3/2 \\ \uparrow\uparrow\downarrow & 1/2 \end{smallmatrix} \right\rangle = \mathbf{P}^{\square\square\square}_{\begin{smallmatrix} a & b & c \\ a & b & c \end{smallmatrix}} |\uparrow, \uparrow, \downarrow\rangle \sqrt{3} = \left(\frac{|\uparrow, \uparrow, \downarrow\rangle + |\uparrow, \downarrow, \uparrow\rangle + |\downarrow, \uparrow, \uparrow\rangle + |\uparrow, \downarrow, \uparrow\rangle + |\downarrow, \uparrow, \uparrow\rangle + |\uparrow, \uparrow, \downarrow\rangle}{\sqrt{6}} \right) = \left(\frac{|\uparrow, \uparrow, \downarrow\rangle + |\uparrow, \downarrow, \uparrow\rangle + |\downarrow, \uparrow, \uparrow\rangle}{\sqrt{3}} \right)$$

$$\left| \begin{smallmatrix} \square\square & \\ \begin{smallmatrix} a & b \\ c \end{smallmatrix} & \begin{smallmatrix} \uparrow\uparrow \\ \downarrow \end{smallmatrix} & 1/2 \end{smallmatrix} \right\rangle = \mathbf{P}^{\square\square}_{\begin{smallmatrix} a & b \\ c & c \end{smallmatrix}} |\uparrow, \uparrow, \downarrow\rangle \sqrt{\frac{3}{2}} = \left(\frac{2|\uparrow, \uparrow, \downarrow\rangle + (-1)|\uparrow, \downarrow, \uparrow\rangle + (-1)|\downarrow, \uparrow, \uparrow\rangle + (-1)|\uparrow, \downarrow, \uparrow\rangle + (-1)|\downarrow, \uparrow, \uparrow\rangle + 2|\uparrow, \uparrow, \downarrow\rangle}{2\sqrt{6}} \right) = \left(\frac{2|\uparrow, \uparrow, \downarrow\rangle + (-1)|\uparrow, \downarrow, \uparrow\rangle + (-1)|\downarrow, \uparrow, \uparrow\rangle}{\sqrt{6}} \right)$$

$$\left| \begin{smallmatrix} \square\square & \\ \begin{smallmatrix} a & c \\ b \end{smallmatrix} & \begin{smallmatrix} \uparrow\uparrow \\ \downarrow \end{smallmatrix} & 1/2 \end{smallmatrix} \right\rangle = \mathbf{P}^{\square\square}_{\begin{smallmatrix} a & c \\ b & c \end{smallmatrix}} |\uparrow, \uparrow, \downarrow\rangle \sqrt{\frac{3}{2}} = \left(\frac{0|\uparrow, \uparrow, \downarrow\rangle + (+1)|\uparrow, \downarrow, \uparrow\rangle + (-1)|\downarrow, \uparrow, \uparrow\rangle + (+1)|\uparrow, \downarrow, \uparrow\rangle + (-1)|\downarrow, \uparrow, \uparrow\rangle + 0|\uparrow, \uparrow, \downarrow\rangle}{2\sqrt{2}} \right) = \left(\frac{(+1)|\uparrow, \downarrow, \uparrow\rangle + (-1)|\downarrow, \uparrow, \uparrow\rangle}{\sqrt{2}} \right)$$

The latter make a permutation doublet.

There are two spin- $S=1/2$ states $\left| \begin{smallmatrix} S=1/2 \\ M=\pm 1/2 \end{smallmatrix} \right\rangle$ but only one spin- $S=3/2$ state $\left| \begin{smallmatrix} S=3/2 \\ M=\pm 1/2 \end{smallmatrix} \right\rangle$ have z-component $M=+1/2$.

All 3 states project from $|\uparrow\uparrow\downarrow\rangle$. The left [j]-labels of the last two make a particle doublet $\left\{ \begin{smallmatrix} a & b & a & c \\ c & b \end{smallmatrix} \right\}$.

State $|\uparrow\uparrow\downarrow\rangle = \mathbf{P}^{\square\square} |\uparrow\uparrow\downarrow\rangle$ is invariant to symmetric subgroup projector $\mathbf{P}^{\square\square} = [1 + (ab)]/2$ but $\mathbf{P}^{\square\square}$ zeros $\begin{smallmatrix} a & c \\ b \end{smallmatrix}$.

$$\left. \begin{array}{l} (ab)|\uparrow, \uparrow, \downarrow\rangle = |\uparrow, \uparrow, \downarrow\rangle \\ \mathbf{P}^{\square\square}_{\begin{smallmatrix} a & b \\ c & b \end{smallmatrix}} (ab) = -\mathbf{P}^{\square\square}_{\begin{smallmatrix} a & b \\ c & a \end{smallmatrix}} \end{array} \right\} \text{implies: } \mathbf{P}^{\square\square}_{\begin{smallmatrix} a & b \\ c & b \end{smallmatrix}} |\uparrow, \uparrow, \downarrow\rangle = -\mathbf{P}^{\square\square}_{\begin{smallmatrix} a & b \\ c & a \end{smallmatrix}} |\uparrow, \uparrow, \downarrow\rangle = 0$$

S_n projection for atomic spin and orbit states: Tableau P-operators on spin

Symmetric $\mathbf{P}^{A_1} = \mathbf{P}^{\square\square\square}$ and para-symmetric $\mathbf{P}^{E_1} = \mathbf{P}^{\square\square}$ projection of $|\uparrow\uparrow\downarrow\rangle$ and $|\uparrow\downarrow\downarrow\rangle$ give $\left| \begin{smallmatrix} S=3/2 \\ M=\pm 1/2 \end{smallmatrix} \right\rangle$ and $\left| \begin{smallmatrix} S=1/2 \\ M=\pm 1/2 \end{smallmatrix} \right\rangle$.

$$\left| \begin{smallmatrix} \square\square\square & 3/2 \\ \uparrow\uparrow\downarrow & 1/2 \end{smallmatrix} \right\rangle = \mathbf{P}^{\square\square\square}_{\begin{smallmatrix} a|b|c \\ a|b|c \end{smallmatrix}} |\uparrow, \uparrow, \downarrow\rangle \sqrt{3} = \left(\frac{|\uparrow, \uparrow, \downarrow\rangle + |\uparrow, \downarrow, \uparrow\rangle + |\downarrow, \uparrow, \uparrow\rangle + |\uparrow, \downarrow, \uparrow\rangle + |\downarrow, \uparrow, \uparrow\rangle + |\uparrow, \uparrow, \downarrow\rangle}{\sqrt{6}} \right) = \left(\frac{|\uparrow, \uparrow, \downarrow\rangle + |\uparrow, \downarrow, \uparrow\rangle + |\downarrow, \uparrow, \uparrow\rangle}{\sqrt{3}} \right)$$

$$\left| \begin{smallmatrix} \square\square & \\ a|b & \uparrow\uparrow \\ c & \downarrow \end{smallmatrix} \begin{smallmatrix} 1/2 \\ 1/2 \end{smallmatrix} \right\rangle = \mathbf{P}^{\square\square}_{\begin{smallmatrix} a|b \\ a|b \\ c \end{smallmatrix}} |\uparrow, \uparrow, \downarrow\rangle \sqrt{\frac{3}{2}} = \left(\frac{2|\uparrow, \uparrow, \downarrow\rangle + (-1)|\uparrow, \downarrow, \uparrow\rangle + (-1)|\downarrow, \uparrow, \uparrow\rangle + (-1)|\uparrow, \downarrow, \uparrow\rangle + (-1)|\downarrow, \uparrow, \uparrow\rangle + 2|\uparrow, \uparrow, \downarrow\rangle}{2\sqrt{6}} \right) = \left(\frac{2|\uparrow, \uparrow, \downarrow\rangle + (-1)|\uparrow, \downarrow, \uparrow\rangle + (-1)|\downarrow, \uparrow, \uparrow\rangle}{\sqrt{6}} \right)$$

$$\left| \begin{smallmatrix} \square\square & \\ a|c & \uparrow\uparrow \\ b & \downarrow \end{smallmatrix} \begin{smallmatrix} 1/2 \\ 1/2 \end{smallmatrix} \right\rangle = \mathbf{P}^{\square\square}_{\begin{smallmatrix} a|c \\ a|b \\ b \end{smallmatrix}} |\uparrow, \uparrow, \downarrow\rangle \sqrt{\frac{3}{2}} = \left(\frac{0|\uparrow, \uparrow, \downarrow\rangle + (+1)|\uparrow, \downarrow, \uparrow\rangle + (-1)|\downarrow, \uparrow, \uparrow\rangle + (+1)|\uparrow, \downarrow, \uparrow\rangle + (-1)|\downarrow, \uparrow, \uparrow\rangle + 0|\uparrow, \uparrow, \downarrow\rangle}{2\sqrt{2}} \right) = \left(\frac{(+1)|\uparrow, \downarrow, \uparrow\rangle + (-1)|\downarrow, \uparrow, \uparrow\rangle}{\sqrt{2}} \right)$$

The latter make a permutation doublet. Similarly, projections of $|\uparrow\downarrow\downarrow\rangle$ give three $M=-1/2$ states.

$$\left| \begin{smallmatrix} \square\square\square & 3/2 \\ \uparrow\uparrow\uparrow & 1/2 \end{smallmatrix} \right\rangle = \mathbf{P}^{\square\square\square}_{\begin{smallmatrix} a|b|c \\ a|b|c \end{smallmatrix}} |\uparrow, \downarrow, \downarrow\rangle \sqrt{3} = \left(\frac{|\uparrow, \downarrow, \downarrow\rangle + |\downarrow, \downarrow, \uparrow\rangle + |\downarrow, \uparrow, \downarrow\rangle + |\uparrow, \downarrow, \downarrow\rangle + |\downarrow, \downarrow, \uparrow\rangle + |\downarrow, \uparrow, \downarrow\rangle}{2\sqrt{3}} \right) = \left(\frac{|\uparrow, \downarrow, \downarrow\rangle + |\downarrow, \uparrow, \downarrow\rangle + |\uparrow, \downarrow, \downarrow\rangle}{\sqrt{3}} \right)$$

$$\left| \begin{smallmatrix} \square\square & \\ a|b & \uparrow\downarrow \\ c & \downarrow \end{smallmatrix} \begin{smallmatrix} 1/2 \\ -1/2 \end{smallmatrix} \right\rangle = \mathbf{P}^{\square\square}_{\begin{smallmatrix} a|b \\ a|b \\ c \end{smallmatrix}} |\uparrow, \downarrow, \downarrow\rangle \sqrt{6} = \left(\frac{2|\uparrow, \downarrow, \downarrow\rangle + (-1)|\downarrow, \downarrow, \uparrow\rangle + (-1)|\downarrow, \uparrow, \downarrow\rangle + (-1)|\uparrow, \downarrow, \downarrow\rangle + (-1)|\downarrow, \downarrow, \uparrow\rangle + 2|\downarrow, \uparrow, \downarrow\rangle}{\sqrt{6}} \right) = \left(\frac{1|\uparrow, \downarrow, \downarrow\rangle + (+1)|\downarrow, \uparrow, \downarrow\rangle + (-2)|\downarrow, \downarrow, \uparrow\rangle}{\sqrt{6}} \right)$$

$$\left| \begin{smallmatrix} \square\square & \\ a|c & \uparrow\downarrow \\ b & \downarrow \end{smallmatrix} \begin{smallmatrix} 1/2 \\ -1/2 \end{smallmatrix} \right\rangle = \mathbf{P}^{\square\square}_{\begin{smallmatrix} a|c \\ a|b \\ b \end{smallmatrix}} |\uparrow, \downarrow, \downarrow\rangle \sqrt{6} = \left(\frac{0|\uparrow, \downarrow, \downarrow\rangle + (+1)|\downarrow, \downarrow, \uparrow\rangle + (-1)|\downarrow, \uparrow, \downarrow\rangle + (+1)|\uparrow, \downarrow, \downarrow\rangle + (-1)|\downarrow, \downarrow, \uparrow\rangle + 0|\downarrow, \uparrow, \downarrow\rangle}{\sqrt{2}} \right) = \left(\frac{(+1)|\uparrow, \downarrow, \downarrow\rangle + (-1)|\downarrow, \uparrow, \downarrow\rangle}{\sqrt{2}} \right)$$

S_n projection for atomic spin and orbit states: Tableau P-operators on spin

Symmetric $\mathbf{P}^{A_1} = \mathbf{P}^{\square\square\square}$ and para-symmetric $\mathbf{P}^{E_1} = \mathbf{P}^{\square\square}$ projection of $|\uparrow\uparrow\downarrow\rangle$ and $|\uparrow\downarrow\downarrow\rangle$ give $\left| \begin{smallmatrix} S=3/2 \\ M=\pm 1/2 \end{smallmatrix} \right\rangle$ and $\left| \begin{smallmatrix} S=1/2 \\ M=\pm 1/2 \end{smallmatrix} \right\rangle$.

$$\left| \begin{smallmatrix} \square\square\square \\ \uparrow\uparrow\downarrow \end{smallmatrix} \begin{smallmatrix} 3/2 \\ 1/2 \end{smallmatrix} \right\rangle = \mathbf{P}_{\begin{smallmatrix} \square\square\square \\ abc \ abc \ abc \end{smallmatrix}} |\uparrow, \uparrow, \downarrow\rangle \sqrt{3} = \left(\frac{|\uparrow, \uparrow, \downarrow\rangle + |\uparrow, \downarrow, \uparrow\rangle + |\downarrow, \uparrow, \uparrow\rangle + |\uparrow, \downarrow, \uparrow\rangle + |\downarrow, \uparrow, \uparrow\rangle + |\uparrow, \uparrow, \downarrow\rangle}{\sqrt{6}} \right) = \left(\frac{|\uparrow, \uparrow, \downarrow\rangle + |\uparrow, \downarrow, \uparrow\rangle + |\downarrow, \uparrow, \uparrow\rangle}{\sqrt{3}} \right)$$

$$\left| \begin{smallmatrix} \square\square \\ \begin{smallmatrix} \square\square \\ abc \ \uparrow\downarrow \end{smallmatrix} \end{smallmatrix} \begin{smallmatrix} 1/2 \\ 1/2 \end{smallmatrix} \right\rangle = \mathbf{P}_{\begin{smallmatrix} \square\square \\ abc \ abc \end{smallmatrix}} |\uparrow, \uparrow, \downarrow\rangle \sqrt{\frac{3}{2}} = \left(\frac{2|\uparrow, \uparrow, \downarrow\rangle + (-1)|\uparrow, \downarrow, \uparrow\rangle + (-1)|\downarrow, \uparrow, \uparrow\rangle + (-1)|\uparrow, \downarrow, \uparrow\rangle + (-1)|\downarrow, \uparrow, \uparrow\rangle + 2|\uparrow, \uparrow, \downarrow\rangle}{2\sqrt{6}} \right) = \left(\frac{2|\uparrow, \uparrow, \downarrow\rangle + (-1)|\uparrow, \downarrow, \uparrow\rangle + (-1)|\downarrow, \uparrow, \uparrow\rangle}{\sqrt{6}} \right)$$

$$\left| \begin{smallmatrix} \square\square \\ \begin{smallmatrix} \square\square \\ abc \ \uparrow\downarrow \end{smallmatrix} \end{smallmatrix} \begin{smallmatrix} 1/2 \\ 1/2 \end{smallmatrix} \right\rangle = \mathbf{P}_{\begin{smallmatrix} \square\square \\ abc \ abc \end{smallmatrix}} |\uparrow, \uparrow, \downarrow\rangle \sqrt{\frac{3}{2}} = \left(\frac{0|\uparrow, \uparrow, \downarrow\rangle + (+1)|\uparrow, \downarrow, \uparrow\rangle + (-1)|\downarrow, \uparrow, \uparrow\rangle + (+1)|\uparrow, \downarrow, \uparrow\rangle + (-1)|\downarrow, \uparrow, \uparrow\rangle + 0|\uparrow, \uparrow, \downarrow\rangle}{2\sqrt{2}} \right) = \left(\frac{(+1)|\uparrow, \downarrow, \uparrow\rangle + (-1)|\downarrow, \uparrow, \uparrow\rangle}{\sqrt{2}} \right)$$

The latter make a permutation doublet. Similarly, projections of $|\uparrow\downarrow\downarrow\rangle$ give three $M=-1/2$ states.

$$\left| \begin{smallmatrix} \square\square\square \\ \uparrow\downarrow\downarrow \end{smallmatrix} \begin{smallmatrix} 3/2 \\ 1/2 \end{smallmatrix} \right\rangle = \mathbf{P}_{\begin{smallmatrix} \square\square\square \\ abc \ abc \ abc \end{smallmatrix}} |\uparrow, \downarrow, \downarrow\rangle \sqrt{3} = \left(\frac{|\uparrow, \downarrow, \downarrow\rangle + |\downarrow, \downarrow, \uparrow\rangle + |\downarrow, \uparrow, \downarrow\rangle + |\uparrow, \downarrow, \downarrow\rangle + |\downarrow, \downarrow, \uparrow\rangle + |\downarrow, \uparrow, \downarrow\rangle}{2\sqrt{3}} \right) = \left(\frac{|\uparrow, \downarrow, \downarrow\rangle + |\downarrow, \uparrow, \downarrow\rangle + |\uparrow, \downarrow, \downarrow\rangle}{\sqrt{3}} \right)$$

$$\left| \begin{smallmatrix} \square\square \\ \begin{smallmatrix} \square\square \\ abc \ \uparrow\downarrow \end{smallmatrix} \end{smallmatrix} \begin{smallmatrix} 1/2 \\ -1/2 \end{smallmatrix} \right\rangle = \mathbf{P}_{\begin{smallmatrix} \square\square \\ abc \ abc \end{smallmatrix}} |\uparrow, \downarrow, \downarrow\rangle \sqrt{6} = \left(\frac{2|\uparrow, \downarrow, \downarrow\rangle + (-1)|\downarrow, \downarrow, \uparrow\rangle + (-1)|\downarrow, \uparrow, \downarrow\rangle + (-1)|\uparrow, \downarrow, \downarrow\rangle + (-1)|\downarrow, \downarrow, \uparrow\rangle + 2|\downarrow, \uparrow, \downarrow\rangle}{\sqrt{6}} \right) = \left(\frac{1|\uparrow, \downarrow, \downarrow\rangle + (+1)|\downarrow, \uparrow, \downarrow\rangle + (-2)|\downarrow, \downarrow, \uparrow\rangle}{\sqrt{6}} \right)$$

$$\left| \begin{smallmatrix} \square\square \\ \begin{smallmatrix} \square\square \\ abc \ \uparrow\downarrow \end{smallmatrix} \end{smallmatrix} \begin{smallmatrix} 1/2 \\ -1/2 \end{smallmatrix} \right\rangle = \mathbf{P}_{\begin{smallmatrix} \square\square \\ abc \ abc \end{smallmatrix}} |\uparrow, \downarrow, \downarrow\rangle \sqrt{6} = \left(\frac{0|\uparrow, \downarrow, \downarrow\rangle + (+1)|\downarrow, \downarrow, \uparrow\rangle + (-1)|\downarrow, \uparrow, \downarrow\rangle + (+1)|\uparrow, \downarrow, \downarrow\rangle + (-1)|\downarrow, \downarrow, \uparrow\rangle + 0|\downarrow, \uparrow, \downarrow\rangle}{\sqrt{2}} \right) = \left(\frac{(+1)|\uparrow, \downarrow, \downarrow\rangle + (-1)|\downarrow, \uparrow, \downarrow\rangle}{\sqrt{2}} \right)$$

Finally, the fourth state of the spin- $S=3/2$ quartet is the following $M=-3/2$.

$$\left| \begin{smallmatrix} \square\square\square \\ \downarrow\downarrow\downarrow \end{smallmatrix} \begin{smallmatrix} 3/2 \\ -3/2 \end{smallmatrix} \right\rangle = \mathbf{P}_{\begin{smallmatrix} \square\square\square \\ abc \ \downarrow\downarrow\downarrow \end{smallmatrix}} |\downarrow, \downarrow, \downarrow\rangle = |\downarrow, \downarrow, \downarrow\rangle$$

S_n projection for atomic spin and orbit states: Tableau P-operators on spin

Symmetric $\mathbf{P}^{A_1} = \mathbf{P}^{\square\square\square}$ and para-symmetric $\mathbf{P}^{E_1} = \mathbf{P}^{\square\square}$ projection of $|\uparrow\uparrow\downarrow\rangle$ and $|\uparrow\downarrow\downarrow\rangle$ give $\left| \begin{smallmatrix} S=3/2 \\ M=\pm 1/2 \end{smallmatrix} \right\rangle$ and $\left| \begin{smallmatrix} S=1/2 \\ M=\pm 1/2 \end{smallmatrix} \right\rangle$.

$$\left| \begin{smallmatrix} \square\square\square & 3/2 \\ \uparrow\uparrow\downarrow & 1/2 \end{smallmatrix} \right\rangle = \mathbf{P}_{\begin{smallmatrix} \square\square\square \\ a\ b\ c \end{smallmatrix}}^{\begin{smallmatrix} \square\square\square \\ a\ b\ c \end{smallmatrix}} |\uparrow, \uparrow, \downarrow\rangle \sqrt{3} = \left(\frac{|\uparrow, \uparrow, \downarrow\rangle + |\uparrow, \downarrow, \uparrow\rangle + |\downarrow, \uparrow, \uparrow\rangle + |\uparrow, \downarrow, \uparrow\rangle + |\downarrow, \uparrow, \uparrow\rangle + |\uparrow, \uparrow, \downarrow\rangle}{\sqrt{6}} \right) = \left(\frac{|\uparrow, \uparrow, \downarrow\rangle + |\uparrow, \downarrow, \uparrow\rangle + |\downarrow, \uparrow, \uparrow\rangle}{\sqrt{3}} \right)$$

$$\left| \begin{smallmatrix} \square\square & \\ \square & \\ a\ b & \uparrow\downarrow \\ c & \uparrow\downarrow \end{smallmatrix} 1/2 \right\rangle = \mathbf{P}_{\begin{smallmatrix} \square\square \\ a\ b \\ c \end{smallmatrix}}^{\begin{smallmatrix} \square\square \\ a\ b \\ c \end{smallmatrix}} |\uparrow, \uparrow, \downarrow\rangle \sqrt{\frac{3}{2}} = \left(\frac{2|\uparrow, \uparrow, \downarrow\rangle + (-1)|\uparrow, \downarrow, \uparrow\rangle + (-1)|\downarrow, \uparrow, \uparrow\rangle + (-1)|\uparrow, \downarrow, \uparrow\rangle + (-1)|\downarrow, \uparrow, \uparrow\rangle + 2|\uparrow, \uparrow, \downarrow\rangle}{2\sqrt{6}} \right) = \left(\frac{2|\uparrow, \uparrow, \downarrow\rangle + (-1)|\uparrow, \downarrow, \uparrow\rangle + (-1)|\downarrow, \uparrow, \uparrow\rangle}{\sqrt{6}} \right)$$

$$\left| \begin{smallmatrix} \square\square & \\ \square & \\ a\ c & \uparrow\uparrow \\ b & \uparrow\downarrow \end{smallmatrix} 1/2 \right\rangle = \mathbf{P}_{\begin{smallmatrix} \square\square \\ a\ c \\ b \end{smallmatrix}}^{\begin{smallmatrix} \square\square \\ a\ b \\ c \end{smallmatrix}} |\uparrow, \uparrow, \downarrow\rangle \sqrt{\frac{3}{2}} = \left(\frac{0|\uparrow, \uparrow, \downarrow\rangle + (+1)|\uparrow, \downarrow, \uparrow\rangle + (-1)|\downarrow, \uparrow, \uparrow\rangle + (+1)|\uparrow, \downarrow, \uparrow\rangle + (-1)|\downarrow, \uparrow, \uparrow\rangle + 0|\uparrow, \uparrow, \downarrow\rangle}{2\sqrt{2}} \right) = \left(\frac{(+1)|\uparrow, \downarrow, \uparrow\rangle + (-1)|\downarrow, \uparrow, \uparrow\rangle}{\sqrt{2}} \right)$$

The latter make a permutation doublet. Similarly, projections of $|\uparrow\downarrow\downarrow\rangle$ give three $M=-1/2$ states.

$$\left| \begin{smallmatrix} \square\square\square & 3/2 \\ \uparrow\uparrow\uparrow & 1/2 \end{smallmatrix} \right\rangle = \mathbf{P}_{\begin{smallmatrix} \square\square\square \\ a\ b\ c \end{smallmatrix}}^{\begin{smallmatrix} \square\square\square \\ a\ b\ c \end{smallmatrix}} |\uparrow, \downarrow, \downarrow\rangle \sqrt{3} = \left(\frac{|\uparrow, \downarrow, \downarrow\rangle + |\downarrow, \downarrow, \uparrow\rangle + |\downarrow, \uparrow, \downarrow\rangle + |\uparrow, \downarrow, \downarrow\rangle + |\downarrow, \downarrow, \uparrow\rangle + |\downarrow, \uparrow, \downarrow\rangle}{2\sqrt{3}} \right) = \left(\frac{|\uparrow, \downarrow, \downarrow\rangle + |\downarrow, \uparrow, \downarrow\rangle + |\uparrow, \downarrow, \downarrow\rangle}{\sqrt{3}} \right)$$

$$\left| \begin{smallmatrix} \square\square & \\ \square & \\ a\ b & \uparrow\downarrow \\ c & \uparrow\downarrow \end{smallmatrix} 1/2 \right\rangle = \mathbf{P}_{\begin{smallmatrix} \square\square \\ a\ b \\ c \end{smallmatrix}}^{\begin{smallmatrix} \square\square \\ a\ b \\ c \end{smallmatrix}} |\uparrow, \downarrow, \downarrow\rangle \sqrt{6} = \left(\frac{2|\uparrow, \downarrow, \downarrow\rangle + (-1)|\downarrow, \downarrow, \uparrow\rangle + (-1)|\downarrow, \uparrow, \downarrow\rangle + (-1)|\uparrow, \downarrow, \downarrow\rangle + (-1)|\downarrow, \downarrow, \uparrow\rangle + 2|\downarrow, \uparrow, \downarrow\rangle}{\sqrt{6}} \right) = \left(\frac{1|\uparrow, \downarrow, \downarrow\rangle + (+1)|\downarrow, \uparrow, \downarrow\rangle + (-2)|\downarrow, \downarrow, \uparrow\rangle}{\sqrt{6}} \right)$$

$$\left| \begin{smallmatrix} \square\square & \\ \square & \\ a\ c & \uparrow\downarrow \\ b & \uparrow\downarrow \end{smallmatrix} 1/2 \right\rangle = \mathbf{P}_{\begin{smallmatrix} \square\square \\ a\ c \\ b \end{smallmatrix}}^{\begin{smallmatrix} \square\square \\ a\ b \\ c \end{smallmatrix}} |\uparrow, \downarrow, \downarrow\rangle \sqrt{6} = \left(\frac{0|\uparrow, \downarrow, \downarrow\rangle + (+1)|\downarrow, \downarrow, \uparrow\rangle + (-1)|\downarrow, \uparrow, \downarrow\rangle + (+1)|\uparrow, \downarrow, \downarrow\rangle + (-1)|\downarrow, \downarrow, \uparrow\rangle + 0|\downarrow, \uparrow, \downarrow\rangle}{\sqrt{2}} \right) = \left(\frac{(+1)|\uparrow, \downarrow, \downarrow\rangle + (-1)|\downarrow, \uparrow, \downarrow\rangle}{\sqrt{2}} \right)$$

Finally, the fourth state of the spin- $S=3/2$ quartet is the following $M=-3/2$.

$$\left| \begin{smallmatrix} \square\square\square & 3/2 \\ \downarrow\downarrow\downarrow & -3/2 \end{smallmatrix} \right\rangle = \mathbf{P}_{\begin{smallmatrix} \square\square\square \\ a\ b\ c \end{smallmatrix}}^{\begin{smallmatrix} \square\square\square \\ \downarrow\downarrow\downarrow \end{smallmatrix}} |\downarrow, \downarrow, \downarrow\rangle = |\downarrow, \downarrow, \downarrow\rangle$$

Right index correlates *state-permutation*-symmetry, that is, whether two spins are equal.

Left index correlates *particle-permutation*-symmetry, that is, whether two particles are the same or not.

4.16.18 class 23: *Symmetry Principles for
Advanced Atomic-Molecular-Optical-Physics*
William G. Harter - University of Arkansas

$(S_n)^*(U(m))$ shell model of electrostatic quadrupole-quadrupole-e interactions

Marrying spin $s=1/2$ and orbital $\ell=1$ together: $U(3)\times U(2)$

The $\ell=1$ p -shell in a nutshell

$U(6)\supset U(3)\times U(2)$ approach: Coupling spin-orbit ($s=1/2$, $\ell=1$) tableaux

Introducing atomic spin-orbit state assembly formula

Slater determinants

p -shell Spin-orbit calculations (not finished)

Clebsch Gordan coefficients. (Rev. Mod. Phys. annual gift)

S_n projection for atomic spin and orbit states

Review of Mach-Mock (particle-state) principle

Tableau P-operators on orbits (Yamououchi formula)

Tableau P-operators on spin

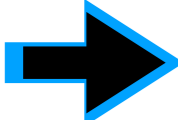
 Fermi-Dirac-Pauli anti-symmetric p^3 -states

Boson operators and symmetric p^2 -states

Connecting to angular momentum

Projecting to angular momentum

Fermi-Dirac-Pauli anti-symmetric p^3 -states

Orbital-tableau states (10 pages above) are combined using S_N -Clebsch-Gordan coefficients (S_N CGC) with spin-tableau states (1 page above) to make Pauli-allowed spin-orbit states.

In the following simplest case the (S_3 CGC) sum is a single term for each state in the 4S quartet.

$$\left| p^3 \ ^4S \begin{array}{ccc|c} \uparrow & \uparrow & \uparrow & 1 \\ \uparrow & \uparrow & \uparrow & 2 \\ \uparrow & \uparrow & \uparrow & 3 \end{array} \begin{array}{l} S=3/2 \\ M_S=3/2 \end{array} \right\rangle = \left| \begin{array}{ccc} \uparrow & \uparrow & \uparrow \\ \uparrow & \uparrow & \uparrow \\ \uparrow & \uparrow & \uparrow \end{array} \right\rangle \left| \begin{array}{c} 1 \\ 2 \\ 3 \end{array} \right\rangle, \quad \left| \begin{array}{l} 3/2 \\ 1/2 \end{array} \right\rangle = \left| \begin{array}{ccc} \uparrow & \uparrow & \downarrow \\ \uparrow & \uparrow & \downarrow \\ \uparrow & \uparrow & \downarrow \end{array} \right\rangle \left| \begin{array}{c} 1 \\ 2 \\ 3 \end{array} \right\rangle, \quad \left| \begin{array}{l} 3/2 \\ -1/2 \end{array} \right\rangle = \left| \begin{array}{ccc} \uparrow & \downarrow & \downarrow \\ \uparrow & \downarrow & \downarrow \\ \uparrow & \downarrow & \downarrow \end{array} \right\rangle \left| \begin{array}{c} 1 \\ 2 \\ 3 \end{array} \right\rangle, \quad \left| \begin{array}{l} 3/2 \\ -3/2 \end{array} \right\rangle = \left| \begin{array}{ccc} \downarrow & \downarrow & \downarrow \\ \downarrow & \downarrow & \downarrow \\ \downarrow & \downarrow & \downarrow \end{array} \right\rangle \left| \begin{array}{c} 1 \\ 2 \\ 3 \end{array} \right\rangle$$

Fermi-Dirac-Pauli anti-symmetric p^3 -states

Orbital-tableau states (10 pages above) are combined using S_N -Clebsch-Gordan coefficients (S_N CGC) with spin-tableau states (1 page above) to make Pauli-allowed spin-orbit states.

In the following simplest case the (S_3 CGC) sum is a single term for each state in the 4S quartet.

$$\left| p^3 \ ^4S \begin{array}{ccc|c} \uparrow & \uparrow & \uparrow & 1 \\ \uparrow & \uparrow & \uparrow & 2 \\ \uparrow & \uparrow & \uparrow & 3 \end{array} M_S=3/2 \right\rangle = \left| \begin{array}{ccc|c} \uparrow & \uparrow & \uparrow & \\ \uparrow & \uparrow & \uparrow & 1 \\ \uparrow & \uparrow & \uparrow & 2 \\ \uparrow & \uparrow & \uparrow & 3 \end{array} \right\rangle, \quad \left| \begin{array}{c} 3/2 \\ 1/2 \end{array} \right\rangle = \left| \begin{array}{ccc|c} \uparrow & \uparrow & \downarrow & \\ \uparrow & \uparrow & \downarrow & 1 \\ \uparrow & \uparrow & \downarrow & 2 \\ \uparrow & \uparrow & \downarrow & 3 \end{array} \right\rangle, \quad \left| \begin{array}{c} 3/2 \\ -1/2 \end{array} \right\rangle = \left| \begin{array}{ccc|c} \uparrow & \downarrow & \downarrow & \\ \uparrow & \downarrow & \downarrow & 1 \\ \uparrow & \downarrow & \downarrow & 2 \\ \uparrow & \downarrow & \downarrow & 3 \end{array} \right\rangle, \quad \left| \begin{array}{c} 3/2 \\ -3/2 \end{array} \right\rangle = \left| \begin{array}{ccc|c} \downarrow & \downarrow & \downarrow & \\ \downarrow & \downarrow & \downarrow & 1 \\ \downarrow & \downarrow & \downarrow & 2 \\ \downarrow & \downarrow & \downarrow & 3 \end{array} \right\rangle$$

The p^3 doublet states 2L , (with L yet to be determined) are each a sum of two terms

They use S_3 coefficients $C_{A B B}^{E_1 E_1 A_2} = 1/\sqrt{2}$ and $C_{B A B}^{E_1 E_1 A_2} = -1/\sqrt{2}$ to give *total Pauli-anti-symmetry* (A_2).

$$\left| p^3 \ ^2L \begin{array}{ccc|c} \uparrow & \uparrow & 1 & 2 \\ \downarrow & \uparrow & 3 & \\ \downarrow & \uparrow & 1 & 2 \\ \downarrow & \uparrow & 3 & \end{array} M_S=1/2 \right\rangle = C_{A B B}^{E_1 E_1 A_2} \left| \begin{array}{cc|} \square & \square \\ a & b \\ c & \end{array} \right\rangle \left| \begin{array}{ccc|c} \square & \square & & \\ a & c & 1 & 2 \\ b & & 3 & \end{array} \right\rangle + C_{B A B}^{E_1 E_1 A_2} \left| \begin{array}{cc|} \square & \square \\ a & c \\ b & \end{array} \right\rangle \left| \begin{array}{ccc|c} \square & \square & & \\ a & b & 1 & 2 \\ c & & 3 & \end{array} \right\rangle$$

$$\left| p^3 \ ^2L \begin{array}{ccc|c} \uparrow & \downarrow & 1 & 2 \\ \downarrow & \uparrow & 3 & \\ \downarrow & \uparrow & 1 & 2 \\ \downarrow & \uparrow & 3 & \end{array} M_S=-1/2 \right\rangle = C_{A B B}^{E_1 E_1 A_2} \left| \begin{array}{cc|} \square & \square \\ a & b \\ c & \end{array} \right\rangle \left| \begin{array}{ccc|c} \square & \square & & \\ a & c & 1 & 2 \\ b & & 3 & \end{array} \right\rangle + C_{B A B}^{E_1 E_1 A_2} \left| \begin{array}{cc|} \square & \square \\ a & c \\ b & \end{array} \right\rangle \left| \begin{array}{ccc|c} \square & \square & & \\ a & b & 1 & 2 \\ c & & 3 & \end{array} \right\rangle$$

$E_1 \otimes E_1$ to A_2
 Clebsch-Gordan coefficients $\pm 1/\sqrt{2}$
 of S_3 (or D_3)

Fermi-Dirac-Pauli anti-symmetric p^3 -states

Orbital-tableau states (10 pages above) are combined using S_N -Clebsch-Gordan coefficients (S_N CGC) with spin-tableau states (1 page above) to make Pauli-allowed spin-orbit states.

In the following simplest case the (S_3 CGC) sum is a single term for each state in the 4S quartet.

$$\left| p^3 \ ^4S \begin{array}{ccc|c} \uparrow & \uparrow & \uparrow & 1 \\ \uparrow & \uparrow & \uparrow & 2 \\ \uparrow & \uparrow & \uparrow & 3 \end{array} M_S=3/2 \right\rangle = \left| \begin{array}{ccc|c} \uparrow & \uparrow & \uparrow & \\ \uparrow & \uparrow & \uparrow & 1 \\ \uparrow & \uparrow & \uparrow & 2 \\ \uparrow & \uparrow & \uparrow & 3 \end{array} \right\rangle, \left| \begin{array}{c} 3/2 \\ 1/2 \end{array} \right\rangle = \left| \begin{array}{ccc|c} \uparrow & \uparrow & \downarrow & \\ \uparrow & \uparrow & \downarrow & 1 \\ \uparrow & \uparrow & \downarrow & 2 \\ \uparrow & \uparrow & \downarrow & 3 \end{array} \right\rangle, \left| \begin{array}{c} 3/2 \\ -1/2 \end{array} \right\rangle = \left| \begin{array}{ccc|c} \uparrow & \downarrow & \downarrow & \\ \uparrow & \downarrow & \downarrow & 1 \\ \uparrow & \downarrow & \downarrow & 2 \\ \uparrow & \downarrow & \downarrow & 3 \end{array} \right\rangle, \left| \begin{array}{c} 3/2 \\ -3/2 \end{array} \right\rangle = \left| \begin{array}{ccc|c} \downarrow & \downarrow & \downarrow & \\ \downarrow & \downarrow & \downarrow & 1 \\ \downarrow & \downarrow & \downarrow & 2 \\ \downarrow & \downarrow & \downarrow & 3 \end{array} \right\rangle$$

The p^3 doublet states 2L , (with L yet to be determined) are each a sum of two terms

They use S_3 coefficients $C_{A B B}^{E_1 E_1 A_2} = 1/\sqrt{2}$ and $C_{B A B}^{E_1 E_1 A_2} = -1/\sqrt{2}$ to give *total Pauli-anti-symmetry* (A_2).

$$\left| p^3 \ ^2L \begin{array}{ccc|c} \uparrow & \uparrow & 1 & 2 \\ \downarrow & \uparrow & 3 & \\ \downarrow & \uparrow & 1 & 2 \\ \downarrow & \uparrow & 3 & \end{array} M_S=1/2 \right\rangle = C_{A B B}^{E_1 E_1 A_2} \left| \begin{array}{cc|} \square & \square \\ a & b \\ c & \end{array} \right\rangle \left| \begin{array}{ccc|c} \square & \square & & \\ a & c & 1 & 2 \\ b & & 3 & \end{array} \right\rangle + C_{B A B}^{E_1 E_1 A_2} \left| \begin{array}{cc|} \square & \square \\ a & c \\ b & \end{array} \right\rangle \left| \begin{array}{ccc|c} \square & \square & & \\ a & b & 1 & 2 \\ c & & 3 & \end{array} \right\rangle$$

$$\left| p^3 \ ^2L \begin{array}{ccc|c} \uparrow & \downarrow & 1 & 2 \\ \downarrow & \uparrow & 3 & \\ \downarrow & \uparrow & 1 & 2 \\ \downarrow & \uparrow & 3 & \end{array} M_S=-1/2 \right\rangle = C_{A B B}^{E_1 E_1 A_2} \left| \begin{array}{cc|} \square & \square \\ a & b \\ c & \end{array} \right\rangle \left| \begin{array}{ccc|c} \square & \square & & \\ a & c & 1 & 2 \\ b & & 3 & \end{array} \right\rangle + C_{B A B}^{E_1 E_1 A_2} \left| \begin{array}{cc|} \square & \square \\ a & c \\ b & \end{array} \right\rangle \left| \begin{array}{ccc|c} \square & \square & & \\ a & b & 1 & 2 \\ c & & 3 & \end{array} \right\rangle$$

$E_1 \otimes E_1$ to A_2
Clebsch-Gordan coefficients $\pm 1/\sqrt{2}$ of S_3 (or D_3)

This is how permutation multiplicity and (abc) labels disappear, killed by Pauli!

Fermi-Dirac-Pauli anti-symmetric p^3 -states

Orbital-tableau states (10 pages above) are combined using S_N -Clebsch-Gordan coefficients (S_N CGC) with spin-tableau states (1 page above) to make Pauli-allowed spin-orbit states.

In the following simplest case the (S_3 CGC) sum is a single term for each state in the 4S quartet.

$$\left| p^3 \ ^4S \begin{array}{ccc|c} \uparrow & \uparrow & \uparrow & 1 \\ \uparrow & \uparrow & \uparrow & 2 \\ \uparrow & \uparrow & \uparrow & 3 \end{array} M_S=3/2 \right\rangle = \left| \begin{array}{ccc|c} \uparrow & \uparrow & \uparrow & \\ \uparrow & \uparrow & \uparrow & 1 \\ \uparrow & \uparrow & \uparrow & 2 \\ \uparrow & \uparrow & \uparrow & 3 \end{array} \right\rangle, \quad \left| \begin{array}{c} 3/2 \\ 1/2 \end{array} \right\rangle = \left| \begin{array}{ccc|c} \uparrow & \uparrow & \downarrow & \\ \uparrow & \uparrow & \downarrow & 1 \\ \uparrow & \uparrow & \downarrow & 2 \\ \uparrow & \uparrow & \downarrow & 3 \end{array} \right\rangle, \quad \left| \begin{array}{c} 3/2 \\ -1/2 \end{array} \right\rangle = \left| \begin{array}{ccc|c} \uparrow & \downarrow & \downarrow & \\ \uparrow & \downarrow & \downarrow & 1 \\ \uparrow & \downarrow & \downarrow & 2 \\ \uparrow & \downarrow & \downarrow & 3 \end{array} \right\rangle, \quad \left| \begin{array}{c} 3/2 \\ -3/2 \end{array} \right\rangle = \left| \begin{array}{ccc|c} \downarrow & \downarrow & \downarrow & \\ \downarrow & \downarrow & \downarrow & 1 \\ \downarrow & \downarrow & \downarrow & 2 \\ \downarrow & \downarrow & \downarrow & 3 \end{array} \right\rangle$$

The p^3 doublet states 2L , (with L yet to be determined) are each a sum of two terms

They use S_3 coefficients $C_{A B B}^{E_1 E_1 A_2} = 1/\sqrt{2}$ and $C_{B A B}^{E_1 E_1 A_2} = -1/\sqrt{2}$ to give *total Pauli-anti-symmetry* (A_2).

$$\left| p^3 \ ^2L \begin{array}{ccc|c} \uparrow & \uparrow & 1 & 2 \\ \downarrow & \uparrow & 3 & \\ \downarrow & \uparrow & 3 & \end{array} M_S=1/2 \right\rangle = C_{A B B}^{E_1 E_1 A_2} \left| \begin{array}{cc|} \square & \square \\ a & b \end{array} \right\rangle \left| \begin{array}{ccc|c} \uparrow & \uparrow & & \\ a & c & 1 & 2 \\ b & & 3 & \end{array} \right\rangle + C_{B A B}^{E_1 E_1 A_2} \left| \begin{array}{cc|} \square & \square \\ a & c \end{array} \right\rangle \left| \begin{array}{ccc|c} \uparrow & \uparrow & & \\ a & b & 1 & 2 \\ c & & 3 & \end{array} \right\rangle$$

$$\left| p^3 \ ^2L \begin{array}{ccc|c} \uparrow & \downarrow & 1 & 2 \\ \downarrow & \uparrow & 3 & \\ \downarrow & \uparrow & 3 & \end{array} M_S=-1/2 \right\rangle = C_{A B B}^{E_1 E_1 A_2} \left| \begin{array}{cc|} \square & \square \\ a & b \end{array} \right\rangle \left| \begin{array}{ccc|c} \uparrow & \downarrow & & \\ a & c & 1 & 2 \\ c & & 3 & \end{array} \right\rangle + C_{B A B}^{E_1 E_1 A_2} \left| \begin{array}{cc|} \square & \square \\ a & c \end{array} \right\rangle \left| \begin{array}{ccc|c} \uparrow & \downarrow & & \\ a & b & 1 & 2 \\ c & & 3 & \end{array} \right\rangle$$

$E_1 \otimes E_1$ to A_2
 Clebsch-Gordan coefficients $\pm 1/\sqrt{2}$ of S_3 (or D_3)

This is how permutation multiplicity and (abc) labels disappear, killed by Pauli!

But, spin degeneracy of 4 quartet-states and 2 doublet-states is still here.

Fermi-Dirac-Pauli anti-symmetric p^3 -states

Orbital-tableau states (10 pages above) are combined using S_N -Clebsch-Gordan coefficients (S_N CGC) with spin-tableau states (1 page above) to make Pauli-allowed spin-orbit states.

In the following simplest case the (S_3 CGC) sum is a single term for each state in the 4S quartet.

$$\left| p^3 \ ^4S \begin{array}{ccc|c} \uparrow & \uparrow & \uparrow & 1 \\ \uparrow & \uparrow & \uparrow & 2 \\ \uparrow & \uparrow & \uparrow & 3 \end{array} M_S=3/2 \right\rangle = \left| \begin{array}{ccc|c} \uparrow & \uparrow & \uparrow & \\ \uparrow & \uparrow & \uparrow & 1 \\ \uparrow & \uparrow & \uparrow & 2 \\ \uparrow & \uparrow & \uparrow & 3 \end{array} \right\rangle, \left| \begin{array}{c} 3/2 \\ 1/2 \end{array} \right\rangle = \left| \begin{array}{ccc|c} \uparrow & \uparrow & \downarrow & \\ \uparrow & \uparrow & \downarrow & 1 \\ \uparrow & \uparrow & \downarrow & 2 \\ \uparrow & \uparrow & \downarrow & 3 \end{array} \right\rangle, \left| \begin{array}{c} 3/2 \\ -1/2 \end{array} \right\rangle = \left| \begin{array}{ccc|c} \uparrow & \downarrow & \downarrow & \\ \uparrow & \downarrow & \downarrow & 1 \\ \uparrow & \downarrow & \downarrow & 2 \\ \uparrow & \downarrow & \downarrow & 3 \end{array} \right\rangle, \left| \begin{array}{c} 3/2 \\ -3/2 \end{array} \right\rangle = \left| \begin{array}{ccc|c} \downarrow & \downarrow & \downarrow & \\ \downarrow & \downarrow & \downarrow & 1 \\ \downarrow & \downarrow & \downarrow & 2 \\ \downarrow & \downarrow & \downarrow & 3 \end{array} \right\rangle$$

The p^3 doublet states 2L , (with L yet to be determined) are each a sum of two terms

They use S_3 coefficients $C_{A B B}^{E_1 E_1 A_2} = 1/\sqrt{2}$ and $C_{B A B}^{E_1 E_1 A_2} = -1/\sqrt{2}$ to give *total Pauli-anti-symmetry* (A_2).

$$\left| p^3 \ ^2L \begin{array}{ccc|c} \uparrow & \uparrow & 1 & 2 \\ \downarrow & \uparrow & 3 & \\ \downarrow & \uparrow & 3 & \end{array} M_S=1/2 \right\rangle = C_{A B B}^{E_1 E_1 A_2} \left| \begin{array}{cc|} \square & \square \\ a & b \\ c & \end{array} \right\rangle \left| \begin{array}{ccc|c} \square & \square & \uparrow & \uparrow \\ a & c & 1 & 2 \\ b & & 3 & \end{array} \right\rangle + C_{B A B}^{E_1 E_1 A_2} \left| \begin{array}{cc|} \square & \square \\ a & c \\ b & \end{array} \right\rangle \left| \begin{array}{ccc|c} \square & \square & \downarrow & \uparrow \\ a & b & 1 & 2 \\ c & & 3 & \end{array} \right\rangle$$

$$\left| p^3 \ ^2L \begin{array}{ccc|c} \uparrow & \downarrow & 1 & 2 \\ \downarrow & \downarrow & 3 & \\ \downarrow & \downarrow & 3 & \end{array} M_S=-1/2 \right\rangle = C_{A B B}^{E_1 E_1 A_2} \left| \begin{array}{cc|} \square & \square \\ a & b \\ c & \end{array} \right\rangle \left| \begin{array}{ccc|c} \square & \square & \uparrow & \downarrow \\ a & c & 1 & 2 \\ b & & 3 & \end{array} \right\rangle + C_{B A B}^{E_1 E_1 A_2} \left| \begin{array}{cc|} \square & \square \\ a & c \\ b & \end{array} \right\rangle \left| \begin{array}{ccc|c} \square & \square & \downarrow & \downarrow \\ a & b & 1 & 2 \\ c & & 3 & \end{array} \right\rangle$$

$E_1 \otimes E_1$ to A_2
Clebsch-Gordan coefficients $\pm 1/\sqrt{2}$ of S_3 (or D_3)

This is how permutation multiplicity and (abc) labels disappear, killed by Pauli!

But, spin degeneracy of 4 quartet-states and 2 doublet-states is still here.

So are *eight* orbital doublet pairs: a *tableau octet* of Pauli-ok unitary $U(3)$ $e^{E_1}=8$ multiplicity E_1 -orbitals.

$$U(3) \text{ octet tableau basis: } \left\{ \begin{array}{c} \begin{array}{|c|c|} \hline 1 & 1 \\ \hline 2 & \end{array}, \begin{array}{|c|c|} \hline 1 & 2 \\ \hline 2 & \end{array}, \begin{array}{|c|c|} \hline 1 & 2 \\ \hline 3 & \end{array}, \begin{array}{|c|c|} \hline 1 & 3 \\ \hline 2 & \end{array}, \begin{array}{|c|c|} \hline 1 & 1 \\ \hline 3 & \end{array}, \begin{array}{|c|c|} \hline 1 & 3 \\ \hline 3 & \end{array}, \begin{array}{|c|c|} \hline 2 & 2 \\ \hline 3 & \end{array}, \begin{array}{|c|c|} \hline 2 & 2 \\ \hline 3 & \end{array}, \begin{array}{|c|c|} \hline 2 & 3 \\ \hline 3 & \end{array} \right\}$$

4.16.18 class 23: *Symmetry Principles for
Advanced Atomic-Molecular-Optical-Physics*
William G. Harter - University of Arkansas

$(S_n)^*(U(m))$ shell model of electrostatic quadrupole-quadrupole-e interactions

Marrying spin $s=1/2$ and orbital $\ell=1$ together: $U(3)\times U(2)$

The $\ell=1$ p -shell in a nutshell

$U(6)\supset U(3)\times U(2)$ approach: Coupling spin-orbit ($s=1/2$, $\ell=1$) tableaux

Introducing atomic spin-orbit state assembly formula

Slater determinants

p -shell Spin-orbit calculations (not finished)

Clebsch Gordan coefficients. (Rev. Mod. Phys. annual gift)

S_n projection for atomic spin and orbit states

Review of Mach-Mock (particle-state) principle

Tableau P-operators on orbits (Yamououchi formula)

Tableau P-operators on spin

Fermi-Dirac-Pauli anti-symmetric p^3 -states

 Boson operators and symmetric p^2 -states

Connecting to angular momentum

Projecting to angular momentum

Boson operators and symmetric p^2 -states

First non-trivial application of elementary creation-destruction pairs is to the [2,0] sextet states

$$\left\{ \left| \begin{array}{|c|c|} \hline 1 & 1 \\ \hline \end{array} \right\rangle, \left| \begin{array}{|c|c|} \hline 1 & 2 \\ \hline \end{array} \right\rangle, \left| \begin{array}{|c|c|} \hline 1 & 3 \\ \hline \end{array} \right\rangle, \left| \begin{array}{|c|c|} \hline 2 & 2 \\ \hline \end{array} \right\rangle, \left| \begin{array}{|c|c|} \hline 2 & 3 \\ \hline \end{array} \right\rangle, \left| \begin{array}{|c|c|} \hline 3 & 3 \\ \hline \end{array} \right\rangle, \right\}$$

Boson operators and symmetric p^2 -states

First non-trivial application of elementary creation-destruction pairs is to the [2,0] sextet states

$$\left\{ \left| \begin{array}{|c|c|} \hline 1 & 1 \\ \hline \end{array} \right\rangle, \left| \begin{array}{|c|c|} \hline 1 & 2 \\ \hline \end{array} \right\rangle, \left| \begin{array}{|c|c|} \hline 1 & 3 \\ \hline \end{array} \right\rangle, \left| \begin{array}{|c|c|} \hline 2 & 2 \\ \hline \end{array} \right\rangle, \left| \begin{array}{|c|c|} \hline 2 & 3 \\ \hline \end{array} \right\rangle, \left| \begin{array}{|c|c|} \hline 3 & 3 \\ \hline \end{array} \right\rangle, \right\}$$

$$E_{12} \left| n_1, n_2 \right\rangle = a_1 \bar{a}_2 \left| n_1, n_2 \right\rangle = a_1 \sqrt{n_2} \left| n_1, n_2 - 1 \right\rangle = \sqrt{n_1 + 1} \sqrt{n_2} \left| n_1 + 1, n_2 - 1 \right\rangle$$

$$E_{23} \left| n_1, n_2, n_3 \right\rangle = a_2 \bar{a}_3 \left| n_1, n_2, n_3 \right\rangle = a_2 \sqrt{n_3} \left| n_1, n_2, n_3 - 1 \right\rangle = \sqrt{n_2 + 1} \sqrt{n_3} \left| n_1, n_2 + 1, n_3 - 1 \right\rangle$$

Boson operators and symmetric p^2 -states

First non-trivial application of elementary creation-destruction pairs is to the $[2,0]$ sextet states

$$\left\{ \left| \begin{array}{|c|} \hline 1 \\ \hline 1 \\ \hline \end{array} \right\rangle, \left| \begin{array}{|c|} \hline 1 \\ \hline 2 \\ \hline \end{array} \right\rangle, \left| \begin{array}{|c|} \hline 1 \\ \hline 3 \\ \hline \end{array} \right\rangle, \left| \begin{array}{|c|} \hline 2 \\ \hline 2 \\ \hline \end{array} \right\rangle, \left| \begin{array}{|c|} \hline 2 \\ \hline 3 \\ \hline \end{array} \right\rangle, \left| \begin{array}{|c|} \hline 3 \\ \hline 3 \\ \hline \end{array} \right\rangle, \right\}$$

$$E_{12} |n_1, n_2\rangle = a_1 \bar{a}_2 |n_1, n_2\rangle = a_1 \sqrt{n_2} |n_1, n_2 - 1\rangle = \sqrt{n_1 + 1} \sqrt{n_2} |n_1 + 1, n_2 - 1\rangle$$

$$E_{23} |n_1, n_2, n_3\rangle = a_2 \bar{a}_3 |n_1, n_2, n_3\rangle = a_2 \sqrt{n_3} |n_1, n_2, n_3 - 1\rangle = \sqrt{n_2 + 1} \sqrt{n_3} |n_1, n_2 + 1, n_3 - 1\rangle$$

Elementary operations e_{jk} apply to each particle a, b, c , and so forth in turn.

$$E_{23} |3_a 3_b 3_c\rangle = |2_a 3_b 3_c\rangle + |3_a 2_b 3_c\rangle + |3_a 3_b 2_c\rangle = \sqrt{3} \frac{|2_a 3_b 3_c\rangle + |3_a 2_b 3_c\rangle + |3_a 3_b 2_c\rangle}{\sqrt{3}} = \sqrt{3} \left| \begin{array}{|c|} \hline 2 \\ \hline 3 \\ \hline 3 \\ \hline \end{array} \right\rangle$$

$$a_2 \bar{a}_3 |n_1 = 0, n_2 = 0, n_3 = 3\rangle = a_2 \sqrt{3} |0, 0, 2\rangle = \sqrt{1} \sqrt{3} |0, 1, 2\rangle = E_{23} \left| \begin{array}{|c|} \hline 3 \\ \hline 3 \\ \hline 3 \\ \hline \end{array} \right\rangle = \sqrt{3} \left| \begin{array}{|c|} \hline 2 \\ \hline 3 \\ \hline 3 \\ \hline \end{array} \right\rangle$$

Boson operators and symmetric p^2 -states

First non-trivial application of elementary creation-destruction pairs is to the $[2,0]$ sextet states

$$\left\{ \left| \begin{array}{|c|} \hline 1 \\ \hline 1 \\ \hline \end{array} \right\rangle, \left| \begin{array}{|c|} \hline 1 \\ \hline 2 \\ \hline \end{array} \right\rangle, \left| \begin{array}{|c|} \hline 1 \\ \hline 3 \\ \hline \end{array} \right\rangle, \left| \begin{array}{|c|} \hline 2 \\ \hline 2 \\ \hline \end{array} \right\rangle, \left| \begin{array}{|c|} \hline 2 \\ \hline 3 \\ \hline \end{array} \right\rangle, \left| \begin{array}{|c|} \hline 3 \\ \hline 3 \\ \hline \end{array} \right\rangle, \right\}$$

$$E_{12} |n_1, n_2\rangle = a_1 \bar{a}_2 |n_1, n_2\rangle = a_1 \sqrt{n_2} |n_1, n_2 - 1\rangle = \sqrt{n_1 + 1} \sqrt{n_2} |n_1 + 1, n_2 - 1\rangle$$

$$E_{23} |n_1, n_2, n_3\rangle = a_2 \bar{a}_3 |n_1, n_2, n_3\rangle = a_2 \sqrt{n_3} |n_1, n_2, n_3 - 1\rangle = \sqrt{n_2 + 1} \sqrt{n_3} |n_1, n_2 + 1, n_3 - 1\rangle$$

Elementary operations e_{jk} apply to each particle a, b, c , and so forth in turn.

$$E_{23} |3_a 3_b 3_c\rangle = |2_a 3_b 3_c\rangle + |3_a 2_b 3_c\rangle + |3_a 3_b 2_c\rangle = \sqrt{3} \frac{|2_a 3_b 3_c\rangle + |3_a 2_b 3_c\rangle + |3_a 3_b 2_c\rangle}{\sqrt{3}} = \sqrt{3} \left| \begin{array}{|c|} \hline 2 \\ \hline 3 \\ \hline 3 \\ \hline \end{array} \right\rangle$$

$$a_2 \bar{a}_3 |n_1 = 0, n_2 = 0, n_3 = 3\rangle = a_2 \sqrt{3} |0, 0, 2\rangle = \sqrt{1} \sqrt{3} |0, 1, 2\rangle = E_{23} \left| \begin{array}{|c|} \hline 3 \\ \hline 3 \\ \hline 3 \\ \hline \end{array} \right\rangle = \sqrt{3} \left| \begin{array}{|c|} \hline 2 \\ \hline 3 \\ \hline 3 \\ \hline \end{array} \right\rangle$$

The e_{jk} procedure shows $a = \mathbf{a}^\dagger$ or $\bar{a} = \mathbf{a}$ factors $\sqrt{n_k}$ or $\sqrt{n_k + 1}$ arise by adjusting norms

Boson operators and symmetric p^2 -states

First non-trivial application of elementary creation-destruction pairs is to the [2,0] sextet states

$$\left\{ \left| \begin{array}{|c|} \hline 1 \\ \hline \end{array} \right| \right\rangle, \left| \begin{array}{|c|} \hline 1 \\ \hline 2 \\ \hline \end{array} \right\rangle, \left| \begin{array}{|c|} \hline 1 \\ \hline 3 \\ \hline \end{array} \right\rangle, \left| \begin{array}{|c|} \hline 2 \\ \hline 2 \\ \hline \end{array} \right\rangle, \left| \begin{array}{|c|} \hline 2 \\ \hline 3 \\ \hline \end{array} \right\rangle, \left| \begin{array}{|c|} \hline 3 \\ \hline 3 \\ \hline \end{array} \right\rangle, \right\}$$

$$E_{12} |n_1, n_2\rangle = a_1 \bar{a}_2 |n_1, n_2\rangle = a_1 \sqrt{n_2} |n_1, n_2 - 1\rangle = \sqrt{n_1 + 1} \sqrt{n_2} |n_1 + 1, n_2 - 1\rangle$$

$$E_{23} |n_1, n_2, n_3\rangle = a_2 \bar{a}_3 |n_1, n_2, n_3\rangle = a_2 \sqrt{n_3} |n_1, n_2, n_3 - 1\rangle = \sqrt{n_2 + 1} \sqrt{n_3} |n_1, n_2 + 1, n_3 - 1\rangle$$

Elementary operations e_{jk} apply to each particle a, b, c , and so forth in turn.

$$E_{23} |3_a 3_b 3_c\rangle = |2_a 3_b 3_c\rangle + |3_a 2_b 3_c\rangle + |3_a 3_b 2_c\rangle = \sqrt{3} \frac{|2_a 3_b 3_c\rangle + |3_a 2_b 3_c\rangle + |3_a 3_b 2_c\rangle}{\sqrt{3}} = \sqrt{3} \left| \begin{array}{|c|} \hline 2 \\ \hline 3 \\ \hline 3 \\ \hline \end{array} \right\rangle$$

$$a_2 \bar{a}_3 |n_1 = 0, n_2 = 0, n_3 = 3\rangle = a_2 \sqrt{3} |0, 0, 2\rangle = \sqrt{1} \sqrt{3} |0, 1, 2\rangle = E_{23} \left| \begin{array}{|c|} \hline 3 \\ \hline 3 \\ \hline 3 \\ \hline \end{array} \right\rangle = \sqrt{3} \left| \begin{array}{|c|} \hline 2 \\ \hline 3 \\ \hline 3 \\ \hline \end{array} \right\rangle$$

The e_{jk} procedure shows $a = \mathbf{a}^\dagger$ or $\bar{a} = \mathbf{a}$ factors $\sqrt{n_k}$ or $\sqrt{n_k + 1}$ arise by adjusting norms

$$\begin{aligned} E_{23} \frac{|2_a 3_b 3_c 3_d\rangle + |3_a 2_b 3_c 3_d\rangle + |3_a 3_b 2_c 3_d\rangle + |3_a 3_b 3_c 2_d\rangle}{2} &= E_{23} \left| \begin{array}{|c|} \hline 2 \\ \hline 3 \\ \hline 3 \\ \hline 3 \\ \hline \end{array} \right\rangle \\ = \frac{|2_a 2_b 3_c 3_d\rangle + |2_a 2_b 3_c 3_d\rangle + |2_a 3_b 2_c 3_d\rangle + |2_a 3_b 3_c 2_d\rangle}{2} &= \sqrt{6} \left[\frac{|2_a 2_b 3_c 3_d\rangle + |2_a 3_b 2_c 3_d\rangle + |2_a 3_b 3_c 2_d\rangle}{\sqrt{6}} \right. \\ + \frac{|2_a 3_b 2_c 3_d\rangle + |3_a 2_b 2_c 3_d\rangle + |3_a 2_b 2_c 3_d\rangle + |3_a 2_b 3_c 2_d\rangle}{2} &+ \left. \frac{|3_a 2_b 2_c 3_d\rangle + |3_a 2_b 3_c 2_d\rangle + |3_a 3_b 2_c 2_d\rangle}{\sqrt{6}} \right] \\ + \frac{|2_a 3_b 3_c 2_d\rangle + |3_a 2_b 3_c 2_d\rangle + |3_a 3_b 2_c 2_d\rangle + |3_a 3_b 2_c 2_d\rangle}{2} &= \sqrt{6} \left| \begin{array}{|c|} \hline 2 \\ \hline 2 \\ \hline 3 \\ \hline 3 \\ \hline \end{array} \right\rangle \end{aligned}$$

4.16.18 class 23: *Symmetry Principles for
Advanced Atomic-Molecular-Optical-Physics*
William G. Harter - University of Arkansas

$(S_n)^*(U(m))$ shell model of electrostatic quadrupole-quadrupole-e interactions

Marrying spin $s=1/2$ and orbital $\ell=1$ together: $U(3)\times U(2)$

The $\ell=1$ p -shell in a nutshell

$U(6)\supset U(3)\times U(2)$ approach: Coupling spin-orbit ($s=1/2$, $\ell=1$) tableaus

Introducing atomic spin-orbit state assembly formula

Slater determinants

p -shell Spin-orbit calculations (not finished)

Clebsch Gordan coefficients. (Rev. Mod. Phys. annual gift)

S_n projection for atomic spin and orbit states

Review of Mach-Mock (particle-state) principle

Tableau P-operators on orbits (Yamououchi formula)

Tableau P-operators on spin

Fermi-Dirac-Pauli anti-symmetric p^3 -states

Boson operators and symmetric p^2 -states

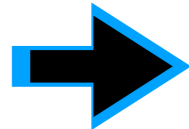

Connecting to angular momentum

Projecting to angular momentum

Boson operators and symmetric p^2 -states: Connecting to angular momentum

Creation operator $(a\bar{a})$ formulas give the same result in more compact notation.

$$E_{23} \left| \begin{array}{|c|c|c|c|} \hline 2 & 3 & 3 & 3 \\ \hline \end{array} \right\rangle = a_2 \bar{a}_3 |n_1 = 0, n_2 = 1, n_3 = 3\rangle = a_2 \sqrt{3} |0, 1, 2\rangle = \sqrt{2} \sqrt{3} |0, 2, 2\rangle = \sqrt{6} \left| \begin{array}{|c|c|c|c|} \hline 2 & 2 & 3 & 3 \\ \hline \end{array} \right\rangle$$

Boson operators and symmetric p^2 -states: Connecting to angular momentum

Creation operator $(a\bar{a})$ formulas give the same result in more compact notation.

$$E_{23} \left| \begin{array}{|c|c|c|c|} \hline 2 & 3 & 3 & 3 \\ \hline \end{array} \right\rangle = a_2 \bar{a}_3 |n_1=0, n_2=1, n_3=3\rangle = a_2 \sqrt{3} |0,1,2\rangle = \sqrt{2} \sqrt{3} |0,2,2\rangle = \sqrt{6} \left| \begin{array}{|c|c|c|c|} \hline 2 & 2 & 3 & 3 \\ \hline \end{array} \right\rangle$$

Matrix elements for $[2,0]$ sextet states involve the following forms.

$$E_{11} \left| \begin{array}{|c|c|} \hline 1 & 1 \\ \hline \end{array} \right\rangle = 2 \left| \begin{array}{|c|c|} \hline 1 & 1 \\ \hline \end{array} \right\rangle, \quad E_{21} \left| \begin{array}{|c|c|} \hline 1 & 1 \\ \hline \end{array} \right\rangle = \sqrt{2} \left| \begin{array}{|c|c|} \hline 1 & 2 \\ \hline \end{array} \right\rangle, \quad E_{21} \left| \begin{array}{|c|c|} \hline 1 & 2 \\ \hline \end{array} \right\rangle = \sqrt{2} \left| \begin{array}{|c|c|} \hline 2 & 2 \\ \hline \end{array} \right\rangle, \quad E_{21} \left| \begin{array}{|c|c|} \hline 1 & 3 \\ \hline \end{array} \right\rangle = \left| \begin{array}{|c|c|} \hline 2 & 3 \\ \hline \end{array} \right\rangle, \quad E_{21} \left| \begin{array}{|c|c|} \hline 2 & 3 \\ \hline \end{array} \right\rangle = 0$$

Boson operators and symmetric p^2 -states: Connecting to angular momentum

Creation operator $(a\bar{a})$ formulas give the same result in more compact notation.

$$E_{23} \left| \begin{array}{|c|c|c|c|} \hline 2 & 3 & 3 & 3 \\ \hline \end{array} \right\rangle = a_2 \bar{a}_3 |n_1=0, n_2=1, n_3=3\rangle = a_2 \sqrt{3} |0,1,2\rangle = \sqrt{2} \sqrt{3} |0,2,2\rangle = \sqrt{6} \left| \begin{array}{|c|c|c|c|} \hline 2 & 2 & 3 & 3 \\ \hline \end{array} \right\rangle$$

Matrix elements for $[2,0]$ sextet states involve the following forms.

$$E_{11} \left| \begin{array}{|c|c|} \hline 1 & 1 \\ \hline \end{array} \right\rangle = 2 \left| \begin{array}{|c|c|} \hline 1 & 1 \\ \hline \end{array} \right\rangle, \quad E_{21} \left| \begin{array}{|c|c|} \hline 1 & 1 \\ \hline \end{array} \right\rangle = \sqrt{2} \left| \begin{array}{|c|c|} \hline 1 & 2 \\ \hline \end{array} \right\rangle, \quad E_{21} \left| \begin{array}{|c|c|} \hline 1 & 2 \\ \hline \end{array} \right\rangle = \sqrt{2} \left| \begin{array}{|c|c|} \hline 2 & 2 \\ \hline \end{array} \right\rangle, \quad E_{21} \left| \begin{array}{|c|c|} \hline 1 & 3 \\ \hline \end{array} \right\rangle = \left| \begin{array}{|c|c|} \hline 2 & 3 \\ \hline \end{array} \right\rangle, \quad E_{21} \left| \begin{array}{|c|c|} \hline 2 & 3 \\ \hline \end{array} \right\rangle = 0$$

Elementary operator representations are then found. (same as earlier cases by other means)

$E_{12} = E_{21}^\dagger =$	<table style="border-collapse: collapse; width: 100%; text-align: center;"> <tr><th style="border-right: 1px solid black; border-bottom: 1px solid black;">11</th><th style="border-bottom: 1px solid black;">12</th><th style="border-bottom: 1px solid black;">22</th><th style="border-bottom: 1px solid black;">13</th><th style="border-bottom: 1px solid black;">23</th><th style="border-bottom: 1px solid black;">33</th></tr> <tr><th style="border-right: 1px solid black;">11</th><td>·</td><td>$\sqrt{2}$</td><td>·</td><td>·</td><td>·</td></tr> <tr><th style="border-right: 1px solid black;">12</th><td>·</td><td>·</td><td>$\sqrt{2}$</td><td>·</td><td>·</td></tr> <tr><th style="border-right: 1px solid black;">22</th><td>·</td><td>·</td><td>·</td><td>·</td><td>·</td></tr> <tr><th style="border-right: 1px solid black;">13</th><td>·</td><td>·</td><td>·</td><td>1</td><td>·</td></tr> <tr><th style="border-right: 1px solid black;">23</th><td>·</td><td>·</td><td>·</td><td>·</td><td>·</td></tr> <tr><th style="border-right: 1px solid black;">33</th><td>·</td><td>·</td><td>·</td><td>·</td><td>·</td></tr> </table>	11	12	22	13	23	33	11	·	$\sqrt{2}$	·	·	·	12	·	·	$\sqrt{2}$	·	·	22	·	·	·	·	·	13	·	·	·	1	·	23	·	·	·	·	·	33	·	·	·	·	·	$E_{23} = E_{32}^\dagger =$	<table style="border-collapse: collapse; width: 100%; text-align: center;"> <tr><th style="border-right: 1px solid black; border-bottom: 1px solid black;">11</th><th style="border-bottom: 1px solid black;">12</th><th style="border-bottom: 1px solid black;">22</th><th style="border-bottom: 1px solid black;">13</th><th style="border-bottom: 1px solid black;">23</th><th style="border-bottom: 1px solid black;">33</th></tr> <tr><th style="border-right: 1px solid black;">11</th><td>·</td><td>·</td><td>·</td><td>·</td><td>·</td></tr> <tr><th style="border-right: 1px solid black;">12</th><td>·</td><td>·</td><td>1</td><td>·</td><td>·</td></tr> <tr><th style="border-right: 1px solid black;">22</th><td>·</td><td>·</td><td>·</td><td>$\sqrt{2}$</td><td>·</td></tr> <tr><th style="border-right: 1px solid black;">13</th><td>·</td><td>·</td><td>·</td><td>·</td><td>·</td></tr> <tr><th style="border-right: 1px solid black;">23</th><td>·</td><td>·</td><td>·</td><td>·</td><td>$\sqrt{2}$</td></tr> <tr><th style="border-right: 1px solid black;">33</th><td>·</td><td>·</td><td>·</td><td>·</td><td>·</td></tr> </table>	11	12	22	13	23	33	11	·	·	·	·	·	12	·	·	1	·	·	22	·	·	·	$\sqrt{2}$	·	13	·	·	·	·	·	23	·	·	·	·	$\sqrt{2}$	33	·	·	·	·	·	$E_{13} = E_{31}^\dagger =$	<table style="border-collapse: collapse; width: 100%; text-align: center;"> <tr><th style="border-right: 1px solid black; border-bottom: 1px solid black;">11</th><th style="border-bottom: 1px solid black;">12</th><th style="border-bottom: 1px solid black;">22</th><th style="border-bottom: 1px solid black;">13</th><th style="border-bottom: 1px solid black;">23</th><th style="border-bottom: 1px solid black;">33</th></tr> <tr><th style="border-right: 1px solid black;">11</th><td>·</td><td>·</td><td>·</td><td>$\sqrt{2}$</td><td>·</td></tr> <tr><th style="border-right: 1px solid black;">12</th><td>·</td><td>·</td><td>·</td><td>·</td><td>1</td></tr> <tr><th style="border-right: 1px solid black;">22</th><td>·</td><td>·</td><td>·</td><td>·</td><td>·</td></tr> <tr><th style="border-right: 1px solid black;">13</th><td>·</td><td>·</td><td>·</td><td>·</td><td>$\sqrt{2}$</td></tr> <tr><th style="border-right: 1px solid black;">23</th><td>·</td><td>·</td><td>·</td><td>·</td><td>·</td></tr> <tr><th style="border-right: 1px solid black;">33</th><td>·</td><td>·</td><td>·</td><td>·</td><td>·</td></tr> </table>	11	12	22	13	23	33	11	·	·	·	$\sqrt{2}$	·	12	·	·	·	·	1	22	·	·	·	·	·	13	·	·	·	·	$\sqrt{2}$	23	·	·	·	·	·	33	·	·	·	·	·
11	12	22	13	23	33																																																																																																																														
11	·	$\sqrt{2}$	·	·	·																																																																																																																														
12	·	·	$\sqrt{2}$	·	·																																																																																																																														
22	·	·	·	·	·																																																																																																																														
13	·	·	·	1	·																																																																																																																														
23	·	·	·	·	·																																																																																																																														
33	·	·	·	·	·																																																																																																																														
11	12	22	13	23	33																																																																																																																														
11	·	·	·	·	·																																																																																																																														
12	·	·	1	·	·																																																																																																																														
22	·	·	·	$\sqrt{2}$	·																																																																																																																														
13	·	·	·	·	·																																																																																																																														
23	·	·	·	·	$\sqrt{2}$																																																																																																																														
33	·	·	·	·	·																																																																																																																														
11	12	22	13	23	33																																																																																																																														
11	·	·	·	$\sqrt{2}$	·																																																																																																																														
12	·	·	·	·	1																																																																																																																														
22	·	·	·	·	·																																																																																																																														
13	·	·	·	·	$\sqrt{2}$																																																																																																																														
23	·	·	·	·	·																																																																																																																														
33	·	·	·	·	·																																																																																																																														

...earlier cases in [Lect.22p17-26](#).

Boson operators and symmetric p^2 -states: Connecting to angular momentum

Creation operator $(a\bar{a})$ formulas give the same result in more compact notation.

$$E_{23} \left| \begin{array}{|c|c|c|c|} \hline 2 & 3 & 3 & 3 \\ \hline \end{array} \right\rangle = a_2 \bar{a}_3 |n_1=0, n_2=1, n_3=3\rangle = a_2 \sqrt{3} |0,1,2\rangle = \sqrt{2}\sqrt{3} |0,2,2\rangle = \sqrt{6} \left| \begin{array}{|c|c|c|c|} \hline 2 & 2 & 3 & 3 \\ \hline \end{array} \right\rangle$$

Matrix elements for $[2,0]$ sextet states involve the following forms.

$$E_{11} \left| \begin{array}{|c|c|} \hline 1 & 1 \\ \hline \end{array} \right\rangle = 2 \left| \begin{array}{|c|c|} \hline 1 & 1 \\ \hline \end{array} \right\rangle, \quad E_{21} \left| \begin{array}{|c|c|} \hline 1 & 1 \\ \hline \end{array} \right\rangle = \sqrt{2} \left| \begin{array}{|c|c|} \hline 1 & 2 \\ \hline \end{array} \right\rangle, \quad E_{21} \left| \begin{array}{|c|c|} \hline 1 & 2 \\ \hline \end{array} \right\rangle = \sqrt{2} \left| \begin{array}{|c|c|} \hline 2 & 2 \\ \hline \end{array} \right\rangle, \quad E_{21} \left| \begin{array}{|c|c|} \hline 1 & 3 \\ \hline \end{array} \right\rangle = \left| \begin{array}{|c|c|} \hline 2 & 3 \\ \hline \end{array} \right\rangle, \quad E_{21} \left| \begin{array}{|c|c|} \hline 2 & 3 \\ \hline \end{array} \right\rangle = 0$$

Elementary operator representations are then found. (same as earlier cases by other means)

$E_{12} = E_{21}^\dagger =$	$E_{23} = E_{32}^\dagger =$	$E_{13} = E_{31}^\dagger =$																																																																																																																																																				
<table style="width:100%; border-collapse: collapse;"> <tr><th></th><th>11</th><th>12</th><th>22</th><th>13</th><th>23</th><th>33</th></tr> <tr><th>11</th><td>.</td><td>$\sqrt{2}$</td><td>.</td><td>.</td><td>.</td><td>.</td></tr> <tr><th>12</th><td>.</td><td>.</td><td>$\sqrt{2}$</td><td>.</td><td>.</td><td>.</td></tr> <tr><th>22</th><td>.</td><td>.</td><td>.</td><td>.</td><td>.</td><td>.</td></tr> <tr><th>13</th><td>.</td><td>.</td><td>.</td><td>.</td><td>1</td><td>.</td></tr> <tr><th>23</th><td>.</td><td>.</td><td>.</td><td>.</td><td>.</td><td>.</td></tr> <tr><th>33</th><td>.</td><td>.</td><td>.</td><td>.</td><td>.</td><td>.</td></tr> </table>		11	12	22	13	23	33	11	.	$\sqrt{2}$	12	.	.	$\sqrt{2}$.	.	.	22	13	1	.	23	33	<table style="width:100%; border-collapse: collapse;"> <tr><th></th><th>11</th><th>12</th><th>22</th><th>13</th><th>23</th><th>33</th></tr> <tr><th>11</th><td>.</td><td>.</td><td>.</td><td>.</td><td>.</td><td>.</td></tr> <tr><th>12</th><td>.</td><td>.</td><td>.</td><td>1</td><td>.</td><td>.</td></tr> <tr><th>22</th><td>.</td><td>.</td><td>.</td><td>.</td><td>$\sqrt{2}$</td><td>.</td></tr> <tr><th>13</th><td>.</td><td>.</td><td>.</td><td>.</td><td>.</td><td>.</td></tr> <tr><th>23</th><td>.</td><td>.</td><td>.</td><td>.</td><td>.</td><td>$\sqrt{2}$</td></tr> <tr><th>33</th><td>.</td><td>.</td><td>.</td><td>.</td><td>.</td><td>.</td></tr> </table>		11	12	22	13	23	33	11	12	.	.	.	1	.	.	22	$\sqrt{2}$.	13	23	$\sqrt{2}$	33	<table style="width:100%; border-collapse: collapse;"> <tr><th></th><th>11</th><th>12</th><th>22</th><th>13</th><th>23</th><th>33</th></tr> <tr><th>11</th><td>.</td><td>.</td><td>.</td><td>$\sqrt{2}$</td><td>.</td><td>.</td></tr> <tr><th>12</th><td>.</td><td>.</td><td>.</td><td>.</td><td>1</td><td>.</td></tr> <tr><th>22</th><td>.</td><td>.</td><td>.</td><td>.</td><td>.</td><td>.</td></tr> <tr><th>13</th><td>.</td><td>.</td><td>.</td><td>.</td><td>.</td><td>$\sqrt{2}$</td></tr> <tr><th>23</th><td>.</td><td>.</td><td>.</td><td>.</td><td>.</td><td>.</td></tr> <tr><th>33</th><td>.</td><td>.</td><td>.</td><td>.</td><td>.</td><td>.</td></tr> </table>		11	12	22	13	23	33	11	.	.	.	$\sqrt{2}$.	.	12	1	.	22	13	$\sqrt{2}$	23	33	<p>...earlier cases in Lect.22p17-26.</p>
	11	12	22	13	23	33																																																																																																																																																
11	.	$\sqrt{2}$																																																																																																																																																
12	.	.	$\sqrt{2}$.	.	.																																																																																																																																																
22																																																																																																																																																
13	1	.																																																																																																																																																
23																																																																																																																																																
33																																																																																																																																																
	11	12	22	13	23	33																																																																																																																																																
11																																																																																																																																																
12	.	.	.	1	.	.																																																																																																																																																
22	$\sqrt{2}$.																																																																																																																																																
13																																																																																																																																																
23	$\sqrt{2}$																																																																																																																																																
33																																																																																																																																																
	11	12	22	13	23	33																																																																																																																																																
11	.	.	.	$\sqrt{2}$.	.																																																																																																																																																
12	1	.																																																																																																																																																
22																																																																																																																																																
13	$\sqrt{2}$																																																																																																																																																
23																																																																																																																																																
33																																																																																																																																																

36 “super-elementary” operators made by products of E_{23} and E_{12} and conjugates $E_{21} = E_{12}^\dagger$ and $E_{32} = E_{23}^\dagger$

$L_+ = L_x + iL_y = \sqrt{2}(E_{12} + E_{23})$	$L_- = L_x - iL_y =$	$L^2 = L_+L_- + L_z(L_z - 1)$	$E_{13} = [E_{12}, E_{23}]$																																																																																																																																																			
<table style="width:100%; border-collapse: collapse;"> <tr><th></th><th>11</th><th>12</th><th>22</th><th>13</th><th>23</th><th>33</th></tr> <tr><th>11</th><td>.</td><td>2</td><td>.</td><td>.</td><td>.</td><td>.</td></tr> <tr><th>12</th><td>.</td><td>.</td><td>2</td><td>$\sqrt{2}$</td><td>.</td><td>.</td></tr> <tr><th>22</th><td>.</td><td>.</td><td>.</td><td>.</td><td>2</td><td>.</td></tr> <tr><th>13</th><td>.</td><td>.</td><td>.</td><td>.</td><td>$\sqrt{2}$</td><td>.</td></tr> <tr><th>23</th><td>.</td><td>.</td><td>.</td><td>.</td><td>.</td><td>2</td></tr> <tr><th>33</th><td>.</td><td>.</td><td>.</td><td>.</td><td>.</td><td>.</td></tr> </table>		11	12	22	13	23	33	11	.	2	12	.	.	2	$\sqrt{2}$.	.	22	2	.	13	$\sqrt{2}$.	23	2	33	<table style="width:100%; border-collapse: collapse;"> <tr><th></th><th>11</th><th>12</th><th>22</th><th>13</th><th>23</th><th>33</th></tr> <tr><th>11</th><td>.</td><td>.</td><td>.</td><td>.</td><td>.</td><td>.</td></tr> <tr><th>12</th><td>2</td><td>.</td><td>.</td><td>.</td><td>.</td><td>.</td></tr> <tr><th>22</th><td>.</td><td>2</td><td>.</td><td>.</td><td>.</td><td>.</td></tr> <tr><th>13</th><td>.</td><td>$\sqrt{2}$</td><td>.</td><td>.</td><td>.</td><td>.</td></tr> <tr><th>23</th><td>.</td><td>.</td><td>2</td><td>$\sqrt{2}$</td><td>.</td><td>.</td></tr> <tr><th>33</th><td>.</td><td>.</td><td>.</td><td>.</td><td>2</td><td>.</td></tr> </table>		11	12	22	13	23	33	11	12	2	22	.	2	13	.	$\sqrt{2}$	23	.	.	2	$\sqrt{2}$.	.	33	2	.	<table style="width:100%; border-collapse: collapse;"> <tr><th></th><th>11</th><th>12</th><th>22</th><th>13</th><th>23</th><th>33</th></tr> <tr><th>11</th><td>4+2</td><td>.</td><td>.</td><td>.</td><td>.</td><td>.</td></tr> <tr><th>12</th><td>.</td><td>6</td><td>.</td><td>.</td><td>.</td><td>.</td></tr> <tr><th>22</th><td>.</td><td>.</td><td>4</td><td>$2\sqrt{2}$</td><td>.</td><td>.</td></tr> <tr><th>13</th><td>.</td><td>.</td><td>$2\sqrt{2}$</td><td>2</td><td>.</td><td>.</td></tr> <tr><th>23</th><td>.</td><td>.</td><td>.</td><td>.</td><td>4+2</td><td>.</td></tr> <tr><th>33</th><td>.</td><td>.</td><td>.</td><td>.</td><td>.</td><td>0+6</td></tr> </table>		11	12	22	13	23	33	11	4+2	12	.	6	22	.	.	4	$2\sqrt{2}$.	.	13	.	.	$2\sqrt{2}$	2	.	.	23	4+2	.	33	0+6	
	11	12	22	13	23	33																																																																																																																																																
11	.	2																																																																																																																																																
12	.	.	2	$\sqrt{2}$.	.																																																																																																																																																
22	2	.																																																																																																																																																
13	$\sqrt{2}$.																																																																																																																																																
23	2																																																																																																																																																
33																																																																																																																																																
	11	12	22	13	23	33																																																																																																																																																
11																																																																																																																																																
12	2																																																																																																																																																
22	.	2																																																																																																																																																
13	.	$\sqrt{2}$																																																																																																																																																
23	.	.	2	$\sqrt{2}$.	.																																																																																																																																																
33	2	.																																																																																																																																																
	11	12	22	13	23	33																																																																																																																																																
11	4+2																																																																																																																																																
12	.	6																																																																																																																																																
22	.	.	4	$2\sqrt{2}$.	.																																																																																																																																																
13	.	.	$2\sqrt{2}$	2	.	.																																																																																																																																																
23	4+2	.																																																																																																																																																
33	0+6																																																																																																																																																

4.16.18 class 23: *Symmetry Principles for
Advanced Atomic-Molecular-Optical-Physics*
William G. Harter - University of Arkansas

$(S_n)^*(U(m))$ shell model of electrostatic quadrupole-quadrupole-e interactions

Marrying spin $s=1/2$ and orbital $\ell=1$ together: $U(3)\times U(2)$

The $\ell=1$ p -shell in a nutshell

$U(6)\supset U(3)\times U(2)$ approach: Coupling spin-orbit ($s=1/2$, $\ell=1$) tableaux

Introducing atomic spin-orbit state assembly formula

Slater determinants

p -shell Spin-orbit calculations (not finished)

Clebsch Gordan coefficients. (Rev. Mod. Phys. annual gift)

S_n projection for atomic spin and orbit states

Review of Mach-Mock (particle-state) principle

Tableau P-operators on orbits (Yamououchi formula)

Tableau P-operators on spin

Fermi-Dirac-Pauli anti-symmetric p^3 -states

Boson operators and symmetric p^2 -states

Connecting to angular momentum

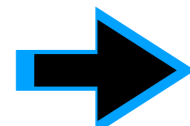
 Projecting to angular momentum

Boson operators and symmetric p^2 -states: Projecting to angular momentum

36 “super-elementary” operators made by products of E_{23} and E_{12} and conjugates $E_{21} = E_{12}^\dagger$ and $E_{32} = E_{23}^\dagger$

$$E_{13} = [E_{12}, E_{23}]$$

$L_+ = L_x + iL_y = \sqrt{2}(E_{12} + E_{23})$	$L_- = L_x^\dagger =$	$L^2 = L_+L_- + L_z(L_z - 1)$																																																																																																																																																			
<table style="border-collapse: collapse; width: 100%; border-top: 1px solid black; border-bottom: 1px solid black;"> <tr> <th style="border-right: 1px solid black; padding: 2px 5px;"></th> <th style="padding: 2px 5px;">11</th> <th style="padding: 2px 5px;">12</th> <th style="padding: 2px 5px;">22</th> <th style="padding: 2px 5px;">13</th> <th style="padding: 2px 5px;">23</th> <th style="padding: 2px 5px;">33</th> </tr> <tr> <th style="border-right: 1px solid black; padding: 2px 5px;">11</th> <td style="padding: 2px 5px;">·</td> <td style="padding: 2px 5px;">2</td> <td style="padding: 2px 5px;">·</td> <td style="padding: 2px 5px;">·</td> <td style="padding: 2px 5px;">·</td> <td style="padding: 2px 5px;">·</td> </tr> <tr> <th style="border-right: 1px solid black; padding: 2px 5px;">12</th> <td style="padding: 2px 5px;">·</td> <td style="padding: 2px 5px;">·</td> <td style="padding: 2px 5px;">2</td> <td style="padding: 2px 5px;">$\sqrt{2}$</td> <td style="padding: 2px 5px;">·</td> <td style="padding: 2px 5px;">·</td> </tr> <tr> <th style="border-right: 1px solid black; padding: 2px 5px;">22</th> <td style="padding: 2px 5px;">·</td> <td style="padding: 2px 5px;">·</td> <td style="padding: 2px 5px;">·</td> <td style="padding: 2px 5px;">·</td> <td style="padding: 2px 5px;">2</td> <td style="padding: 2px 5px;">·</td> </tr> <tr> <th style="border-right: 1px solid black; padding: 2px 5px;">13</th> <td style="padding: 2px 5px;">·</td> <td style="padding: 2px 5px;">·</td> <td style="padding: 2px 5px;">·</td> <td style="padding: 2px 5px;">·</td> <td style="padding: 2px 5px;">$\sqrt{2}$</td> <td style="padding: 2px 5px;">·</td> </tr> <tr> <th style="border-right: 1px solid black; padding: 2px 5px;">23</th> <td style="padding: 2px 5px;">·</td> <td style="padding: 2px 5px;">·</td> <td style="padding: 2px 5px;">·</td> <td style="padding: 2px 5px;">·</td> <td style="padding: 2px 5px;">·</td> <td style="padding: 2px 5px;">2</td> </tr> <tr> <th style="border-right: 1px solid black; padding: 2px 5px;">33</th> <td style="padding: 2px 5px;">·</td> <td style="padding: 2px 5px;">·</td> <td style="padding: 2px 5px;">·</td> <td style="padding: 2px 5px;">·</td> <td style="padding: 2px 5px;">·</td> <td style="padding: 2px 5px;">·</td> </tr> </table>		11	12	22	13	23	33	11	·	2	·	·	·	·	12	·	·	2	$\sqrt{2}$	·	·	22	·	·	·	·	2	·	13	·	·	·	·	$\sqrt{2}$	·	23	·	·	·	·	·	2	33	·	·	·	·	·	·	<table style="border-collapse: collapse; width: 100%; border-top: 1px solid black; border-bottom: 1px solid black;"> <tr> <th style="border-right: 1px solid black; padding: 2px 5px;"></th> <th style="padding: 2px 5px;">11</th> <th style="padding: 2px 5px;">12</th> <th style="padding: 2px 5px;">22</th> <th style="padding: 2px 5px;">13</th> <th style="padding: 2px 5px;">23</th> <th style="padding: 2px 5px;">33</th> </tr> <tr> <th style="border-right: 1px solid black; padding: 2px 5px;">11</th> <td style="padding: 2px 5px;">·</td> <td style="padding: 2px 5px;">·</td> <td style="padding: 2px 5px;">·</td> <td style="padding: 2px 5px;">·</td> <td style="padding: 2px 5px;">·</td> <td style="padding: 2px 5px;">·</td> </tr> <tr> <th style="border-right: 1px solid black; padding: 2px 5px;">12</th> <td style="padding: 2px 5px;">2</td> <td style="padding: 2px 5px;">·</td> <td style="padding: 2px 5px;">·</td> <td style="padding: 2px 5px;">·</td> <td style="padding: 2px 5px;">·</td> <td style="padding: 2px 5px;">·</td> </tr> <tr> <th style="border-right: 1px solid black; padding: 2px 5px;">22</th> <td style="padding: 2px 5px;">·</td> <td style="padding: 2px 5px;">2</td> <td style="padding: 2px 5px;">·</td> <td style="padding: 2px 5px;">·</td> <td style="padding: 2px 5px;">·</td> <td style="padding: 2px 5px;">·</td> </tr> <tr> <th style="border-right: 1px solid black; padding: 2px 5px;">13</th> <td style="padding: 2px 5px;">·</td> <td style="padding: 2px 5px;">$\sqrt{2}$</td> <td style="padding: 2px 5px;">·</td> <td style="padding: 2px 5px;">·</td> <td style="padding: 2px 5px;">·</td> <td style="padding: 2px 5px;">·</td> </tr> <tr> <th style="border-right: 1px solid black; padding: 2px 5px;">23</th> <td style="padding: 2px 5px;">·</td> <td style="padding: 2px 5px;">·</td> <td style="padding: 2px 5px;">2</td> <td style="padding: 2px 5px;">$\sqrt{2}$</td> <td style="padding: 2px 5px;">·</td> <td style="padding: 2px 5px;">·</td> </tr> <tr> <th style="border-right: 1px solid black; padding: 2px 5px;">33</th> <td style="padding: 2px 5px;">·</td> <td style="padding: 2px 5px;">·</td> <td style="padding: 2px 5px;">·</td> <td style="padding: 2px 5px;">·</td> <td style="padding: 2px 5px;">2</td> <td style="padding: 2px 5px;">·</td> </tr> </table>		11	12	22	13	23	33	11	·	·	·	·	·	·	12	2	·	·	·	·	·	22	·	2	·	·	·	·	13	·	$\sqrt{2}$	·	·	·	·	23	·	·	2	$\sqrt{2}$	·	·	33	·	·	·	·	2	·	<table style="border-collapse: collapse; width: 100%; border-top: 1px solid black; border-bottom: 1px solid black;"> <tr> <th style="border-right: 1px solid black; padding: 2px 5px;"></th> <th style="padding: 2px 5px;">11</th> <th style="padding: 2px 5px;">12</th> <th style="padding: 2px 5px;">22</th> <th style="padding: 2px 5px;">13</th> <th style="padding: 2px 5px;">23</th> <th style="padding: 2px 5px;">33</th> </tr> <tr> <th style="border-right: 1px solid black; padding: 2px 5px;">11</th> <td style="padding: 2px 5px;">4+2</td> <td style="padding: 2px 5px;">·</td> <td style="padding: 2px 5px;">·</td> <td style="padding: 2px 5px;">·</td> <td style="padding: 2px 5px;">·</td> <td style="padding: 2px 5px;">·</td> </tr> <tr> <th style="border-right: 1px solid black; padding: 2px 5px;">12</th> <td style="padding: 2px 5px;">·</td> <td style="padding: 2px 5px;">6</td> <td style="padding: 2px 5px;">·</td> <td style="padding: 2px 5px;">·</td> <td style="padding: 2px 5px;">·</td> <td style="padding: 2px 5px;">·</td> </tr> <tr> <th style="border-right: 1px solid black; padding: 2px 5px;">22</th> <td style="padding: 2px 5px;">·</td> <td style="padding: 2px 5px;">·</td> <td style="padding: 2px 5px;">4</td> <td style="padding: 2px 5px;">$2\sqrt{2}$</td> <td style="padding: 2px 5px;">·</td> <td style="padding: 2px 5px;">·</td> </tr> <tr> <th style="border-right: 1px solid black; padding: 2px 5px;">13</th> <td style="padding: 2px 5px;">·</td> <td style="padding: 2px 5px;">·</td> <td style="padding: 2px 5px;">$2\sqrt{2}$</td> <td style="padding: 2px 5px;">2</td> <td style="padding: 2px 5px;">·</td> <td style="padding: 2px 5px;">·</td> </tr> <tr> <th style="border-right: 1px solid black; padding: 2px 5px;">23</th> <td style="padding: 2px 5px;">·</td> <td style="padding: 2px 5px;">·</td> <td style="padding: 2px 5px;">·</td> <td style="padding: 2px 5px;">·</td> <td style="padding: 2px 5px;">4+2</td> <td style="padding: 2px 5px;">·</td> </tr> <tr> <th style="border-right: 1px solid black; padding: 2px 5px;">33</th> <td style="padding: 2px 5px;">·</td> <td style="padding: 2px 5px;">·</td> <td style="padding: 2px 5px;">·</td> <td style="padding: 2px 5px;">·</td> <td style="padding: 2px 5px;">·</td> <td style="padding: 2px 5px;">0+6</td> </tr> </table>		11	12	22	13	23	33	11	4+2	·	·	·	·	·	12	·	6	·	·	·	·	22	·	·	4	$2\sqrt{2}$	·	·	13	·	·	$2\sqrt{2}$	2	·	·	23	·	·	·	·	4+2	·	33	·	·	·	·	·	0+6
	11	12	22	13	23	33																																																																																																																																															
11	·	2	·	·	·	·																																																																																																																																															
12	·	·	2	$\sqrt{2}$	·	·																																																																																																																																															
22	·	·	·	·	2	·																																																																																																																																															
13	·	·	·	·	$\sqrt{2}$	·																																																																																																																																															
23	·	·	·	·	·	2																																																																																																																																															
33	·	·	·	·	·	·																																																																																																																																															
	11	12	22	13	23	33																																																																																																																																															
11	·	·	·	·	·	·																																																																																																																																															
12	2	·	·	·	·	·																																																																																																																																															
22	·	2	·	·	·	·																																																																																																																																															
13	·	$\sqrt{2}$	·	·	·	·																																																																																																																																															
23	·	·	2	$\sqrt{2}$	·	·																																																																																																																																															
33	·	·	·	·	2	·																																																																																																																																															
	11	12	22	13	23	33																																																																																																																																															
11	4+2	·	·	·	·	·																																																																																																																																															
12	·	6	·	·	·	·																																																																																																																																															
22	·	·	4	$2\sqrt{2}$	·	·																																																																																																																																															
13	·	·	$2\sqrt{2}$	2	·	·																																																																																																																																															
23	·	·	·	·	4+2	·																																																																																																																																															
33	·	·	·	·	·	0+6																																																																																																																																															

Angular-momentum-squared operator $\langle L^2 \rangle = L(L+1)$ tells what L -values are present

$$L_+L_- = (L_x + iL_y)(L_x - iL_y) = L_x^2 + L_y^2 - iL_xL_y + iL_yL_x = L_x^2 + L_y^2 + L_z$$

$$L_x^2 + L_y^2 + L_z^2 = L_+L_- + L_z^2 - L_z$$

Boson operators and symmetric p^2 -states: Projecting to angular momentum

36 “super-elementary” operators made by products of E_{23} and E_{12} and conjugates $E_{21} = E_{12}^\dagger$ and $E_{32} = E_{23}^\dagger$

$$E_{13} = [E_{12}, E_{23}]$$

$L_+ = L_x + iL_y = \sqrt{2}(E_{12} + E_{23})$							$L_- = L_x^\dagger =$							$L^2 = L_+L_- + L_z(L_z - 1)$						
	11	12	22	13	23	33		11	12	22	13	23	33		11	12	22	13	23	33
11	.	2	11	11	4+2
12	.	.	2	$\sqrt{2}$.	.	12	2	12	.	6
22	2	.	22	.	2	22	.	.	4	$2\sqrt{2}$.	.
13	$\sqrt{2}$.	13	.	$\sqrt{2}$	13	.	.	$2\sqrt{2}$	2	.	.
23	2	23	.	.	2	$\sqrt{2}$.	.	23	4+2	.
33	33	2	.	33	0+6

Angular-momentum-squared operator $\langle L^2 \rangle = L(L+1)$ tells what L -values are present

$$L_+L_- = (L_x + iL_y)(L_x - iL_y) = L_x^2 + L_y^2 - iL_xL_y + iL_yL_x = L_x^2 + L_y^2 + L_z$$

$$L_x^2 + L_y^2 + L_z^2 = L_+L_- + L_z^2 - L_z$$

Commutation $[L_x, L_y] = L_xL_y - L_yL_x = iL_z$ helps find L^2 matrices. Of 6 e-values, 5 are $L(L+1) = 6$
 The 6th L -value ($L=0$) implies an S-orbital. Both are projected. ($L=2$) or D-orbital)

$$P(L=0) = \frac{\begin{pmatrix} 4-2(2+1) & 2\sqrt{2} \\ 2\sqrt{2} & 2-2(2+1) \end{pmatrix}}{0(0+1)-2(2+1)} = \frac{1}{3} \begin{pmatrix} 1 & -\sqrt{2} \\ -\sqrt{2} & 2 \end{pmatrix}$$

$$P(L=2) = \frac{1}{3} \begin{pmatrix} 2 & \sqrt{2} \\ \sqrt{2} & 1 \end{pmatrix}$$

Boson operators and symmetric p^2 -states: Projecting to angular momentum

36 “super-elementary” operators made by products of E_{23} and E_{12} and conjugates $E_{21} = E_{12}^\dagger$ and $E_{32} = E_{23}^\dagger$

$$E_{13} = [E_{12}, E_{23}]$$

$L_+ = L_x + iL_y = \sqrt{2}(E_{12} + E_{23})$							$L_- = L_x - iL_y =$							$L^2 = L_+L_- + L_z(L_z - 1)$						
	11	12	22	13	23	33		11	12	22	13	23	33		11	12	22	13	23	33
11	.	2	11	11	4+2
12	.	.	2	$\sqrt{2}$.	.	12	2	12	.	6
22	2	.	22	.	2	22	.	.	4	$2\sqrt{2}$.	.
13	$\sqrt{2}$.	13	.	$\sqrt{2}$	13	.	.	$2\sqrt{2}$	2	.	.
23	2	23	.	.	2	$\sqrt{2}$.	.	23	4+2	.
33	33	2	.	33	0+6

Angular-momentum-squared operator $\langle L^2 \rangle = L(L+1)$ tells what L -values are present

$$L_+L_- = (L_x + iL_y)(L_x - iL_y) = L_x^2 + L_y^2 - iL_xL_y + iL_yL_x = L_x^2 + L_y^2 + L_z$$

$$L_x^2 + L_y^2 + L_z^2 = L_+L_- + L_z^2 - L_z$$

Commutation $[L_x, L_y] = L_xL_y - L_yL_x = iL_z$ helps find L^2 matrices. Of 6 e-values, 5 are $L(L+1) = 6$
 The 6th L -value ($L=0$) implies an S-orbital. Both are projected. ($(L=2)$ or D-orbital)

$$P(L=0) = \frac{\begin{pmatrix} 4-2(2+1) & 2\sqrt{2} \\ 2\sqrt{2} & 2-2(2+1) \end{pmatrix}}{0(0+1) - 2(2+1)} = \frac{1}{3} \begin{pmatrix} 1 & -\sqrt{2} \\ -\sqrt{2} & 2 \end{pmatrix}$$

$$P(L=2) = \frac{1}{3} \begin{pmatrix} 2 & \sqrt{2} \\ \sqrt{2} & 1 \end{pmatrix}$$

Resulting transformation results for sextet tableau $\begin{bmatrix} 2 & 2 \end{bmatrix}$ and $\begin{bmatrix} 1 & 3 \end{bmatrix}$ to L -orbitals with $M=0$.

$$\begin{pmatrix} \langle \begin{bmatrix} 2 & 2 \end{bmatrix} |_{M=0}^{L=0} \rangle & \langle \begin{bmatrix} 2 & 2 \end{bmatrix} |_{M=0}^{L=2} \rangle \\ \langle \begin{bmatrix} 1 & 3 \end{bmatrix} |_{M=0}^{L=0} \rangle & \langle \begin{bmatrix} 1 & 3 \end{bmatrix} |_{M=0}^{L=2} \rangle \end{pmatrix} = \begin{pmatrix} \langle \begin{bmatrix} 0 & 0 \end{bmatrix} |_{0}^0 \rangle & \langle \begin{bmatrix} 0 & 0 \end{bmatrix} |_{0}^2 \rangle \\ \langle \begin{bmatrix} +1 & -1 \end{bmatrix} |_{0}^0 \rangle & \langle \begin{bmatrix} +1 & -1 \end{bmatrix} |_{0}^2 \rangle \end{pmatrix} = \begin{pmatrix} \frac{1}{\sqrt{3}} & \frac{\sqrt{2}}{\sqrt{3}} \\ -\frac{\sqrt{2}}{\sqrt{3}} & \frac{1}{\sqrt{3}} \end{pmatrix}$$

(push-to-top)

Boson operators and symmetric p^2 -states: Projecting to angular momentum

Commutation $[L_x, L_y] = L_x L_y - L_y L_x = i L_z$ helps find matrices.

The 6th L -value ($L=0$) implies an S-orbital. Both are projected.

$$P(L=0) = \frac{\begin{pmatrix} 4-2(2+1) & 2\sqrt{2} \\ 2\sqrt{2} & 2-2(2+1) \end{pmatrix}}{0(0+1)-2(2+1)} = \frac{1}{3} \begin{pmatrix} 1 & -\sqrt{2} \\ -\sqrt{2} & 2 \end{pmatrix}$$

Resulting transformation results for sextet tableau $|\begin{smallmatrix} 2 & 2 \end{smallmatrix}\rangle$ and $|\begin{smallmatrix} 1 & 3 \end{smallmatrix}\rangle$ to L -orbitals with $M=0$.

$$\begin{pmatrix} \langle \begin{smallmatrix} 2 & 2 \\ M=0 \end{smallmatrix} | L=0 \rangle & \langle \begin{smallmatrix} 2 & 2 \\ M=0 \end{smallmatrix} | L=2 \rangle \\ \langle \begin{smallmatrix} 1 & 3 \\ M=0 \end{smallmatrix} | L=0 \rangle & \langle \begin{smallmatrix} 1 & 3 \\ M=0 \end{smallmatrix} | L=2 \rangle \end{pmatrix} = \begin{pmatrix} \langle \begin{smallmatrix} 0 & 0 \\ 0 \end{smallmatrix} | 0 \rangle & \langle \begin{smallmatrix} 0 & 0 \\ 0 \end{smallmatrix} | 2 \rangle \\ \langle \begin{smallmatrix} +1 & -1 \\ 0 \end{smallmatrix} | 0 \rangle & \langle \begin{smallmatrix} +1 & -1 \\ 0 \end{smallmatrix} | 2 \rangle \end{pmatrix} = \begin{pmatrix} \sqrt{\frac{1}{3}} & \sqrt{\frac{2}{3}} \\ -\sqrt{\frac{2}{3}} & \sqrt{\frac{1}{3}} \end{pmatrix}$$

(pushed-to-top)

Boson operators and symmetric p^2 -states: Projecting to angular momentum

Commutation $[L_x, L_y] = L_x L_y - L_y L_x = i L_z$ helps find matrices.

The 6th L -value ($L=0$) implies an S-orbital. Both are projected.

$$P(L=0) = \frac{\begin{pmatrix} 4-2(2+1) & 2\sqrt{2} \\ 2\sqrt{2} & 2-2(2+1) \end{pmatrix}}{0(0+1)-2(2+1)} = \frac{1}{3} \begin{pmatrix} 1 & -\sqrt{2} \\ -\sqrt{2} & 2 \end{pmatrix}$$

Resulting transformation results for sextet tableau $\begin{bmatrix} 2 & 2 \end{bmatrix}$ and $\begin{bmatrix} 1 & 3 \end{bmatrix}$ to L -orbitals with $M=0$.

$$\begin{pmatrix} \langle \begin{bmatrix} 2 & 2 \end{bmatrix} |_{M=0}^{L=0} \rangle & \langle \begin{bmatrix} 2 & 2 \end{bmatrix} |_{M=0}^{L=2} \rangle \\ \langle \begin{bmatrix} 1 & 3 \end{bmatrix} |_{M=0}^{L=0} \rangle & \langle \begin{bmatrix} 1 & 3 \end{bmatrix} |_{M=0}^{L=2} \rangle \end{pmatrix} = \begin{pmatrix} \langle \begin{bmatrix} 0 & 0 \end{bmatrix} |_{0}^0 \rangle & \langle \begin{bmatrix} 0 & 0 \end{bmatrix} |_{0}^2 \rangle \\ \langle \begin{bmatrix} +1 & -1 \end{bmatrix} |_{0}^0 \rangle & \langle \begin{bmatrix} +1 & -1 \end{bmatrix} |_{0}^2 \rangle \end{pmatrix} = \begin{pmatrix} \sqrt{\frac{1}{3}} & \sqrt{\frac{2}{3}} \\ -\sqrt{\frac{2}{3}} & \sqrt{\frac{1}{3}} \end{pmatrix}$$

Compare this to ($M=0$)-Clebsch-Gordan coefficients under $\begin{bmatrix} 2 \\ 0 \end{bmatrix}$ and $\begin{bmatrix} 0 \\ 0 \end{bmatrix}$ columns:

$$\begin{aligned} |1 \otimes 1 \rangle_{M=0}^{L=0} &= \sum C_{mm'0}^{110} |1 \rangle_0 |1 \rangle_0 \\ &= C_{000}^{110} |1 \rangle_0 |1 \rangle_0 + C_{+1-1 0}^{110} |1 \rangle_{+1} |1 \rangle_{-1} + C_{-1+1 0}^{110} |1 \rangle_{-1} |1 \rangle_{+1} \\ &= -\sqrt{\frac{1}{3}} |1 \rangle_0 |1 \rangle_0 + \sqrt{\frac{1}{3}} |1 \rangle_{+1} |1 \rangle_{-1} + \sqrt{\frac{1}{3}} |1 \rangle_{-1} |1 \rangle_{+1} \\ &= -\sqrt{\frac{1}{3}} \begin{bmatrix} 0 & 0 \end{bmatrix} + \sqrt{\frac{2}{3}} \begin{bmatrix} +1 & -1 \end{bmatrix} \end{aligned}$$

$$\begin{aligned} |1 \otimes 1 \rangle_{M=0}^{L=2} &= \sum C_{mm'0}^{112} |1 \rangle_0 |1 \rangle_0 \\ &= C_{000}^{112} |1 \rangle_0 |1 \rangle_0 + C_{+1-1 0}^{112} |1 \rangle_{+1} |1 \rangle_{-1} + C_{-1+1 0}^{112} |1 \rangle_{-1} |1 \rangle_{+1} \\ &= \sqrt{\frac{2}{3}} |1 \rangle_0 |1 \rangle_0 + \sqrt{\frac{1}{6}} |1 \rangle_{+1} |1 \rangle_{-1} + \sqrt{\frac{1}{6}} |1 \rangle_{-1} |1 \rangle_{+1} \\ &= \sqrt{\frac{2}{3}} \begin{bmatrix} 0 & 0 \end{bmatrix} + \sqrt{\frac{1}{3}} \begin{bmatrix} +1 & -1 \end{bmatrix} \end{aligned}$$

(end for 4.18)

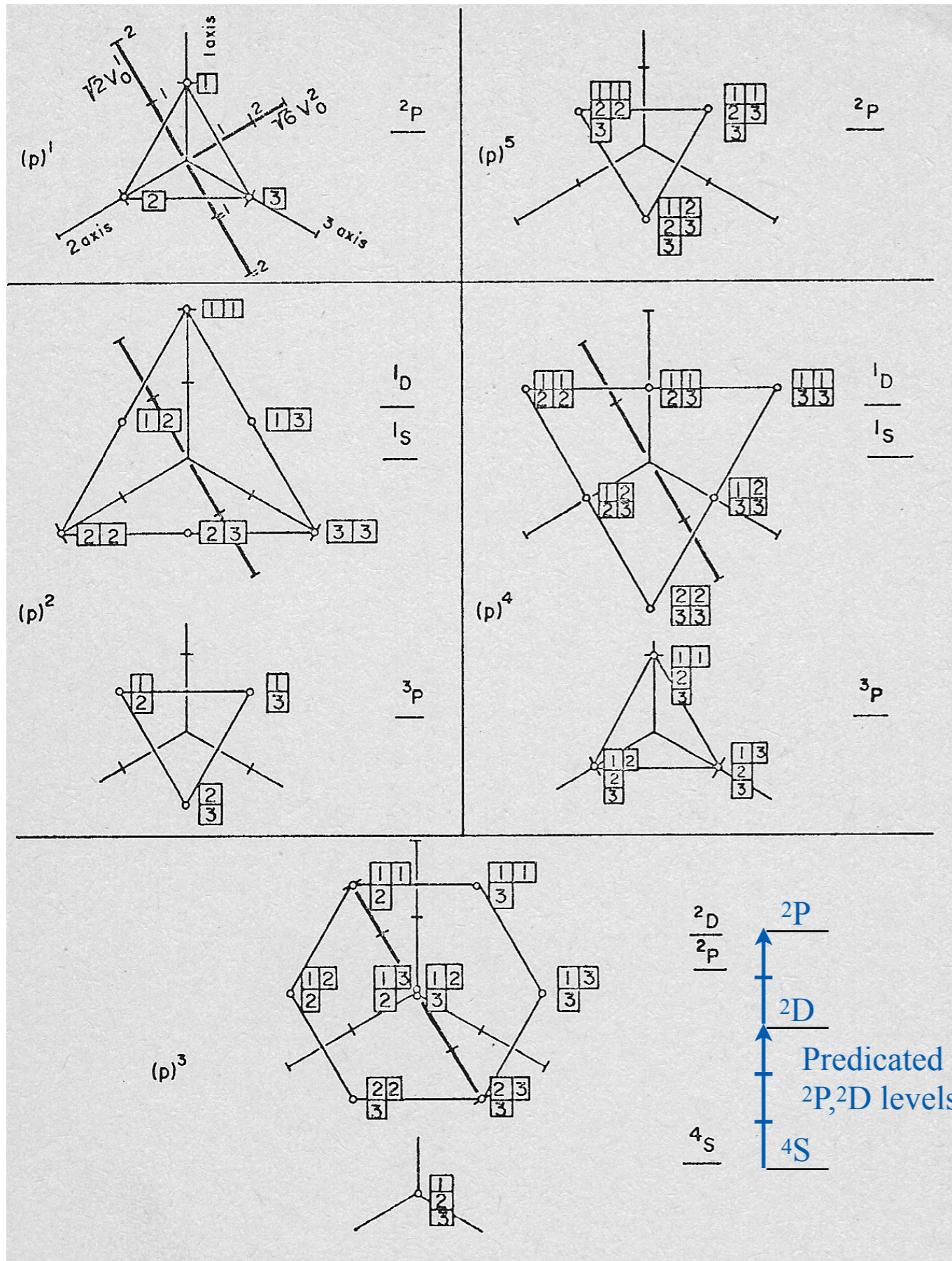

Fig.8 Weight or Moment Diagrams of Atomic $(p)^n$ States
 Each tableau is located at point $(x_1 \ x_2 \ x_3)$ in a cartesian co-ordinate system for which x_n is the number of n's in the tableau. An alternative co-ordinate system is (v_0^2, v_0^1, v_0^0) defined by Eq.16 which gives the zz -quadrupole moment, z -magnetic dipole moment, and number of particles, respectively. The last axis (v_0^0) would be pointing straight out of the figure, and each family of states lies in a plane perpendicular to it.

A Unitary Calculus for Electronic Orbitals
 William G. Harter and Christopher W. Patterson
 Springer-Verlag Lectures in Physics 49 1976

Alternative basis for the theory of complex spectra I
 William G. Harter
 Physical Review A 8 3 p2819 (1973)

Alternative basis for the theory of complex spectra II
 William G. Harter and Christopher W. Patterson
 Physical Review A 13 3 p1076-1082 (1976)

Alternative basis for the theory of complex spectra III
 William G. Harter and Christopher W. Patterson
 Physical Review A ??

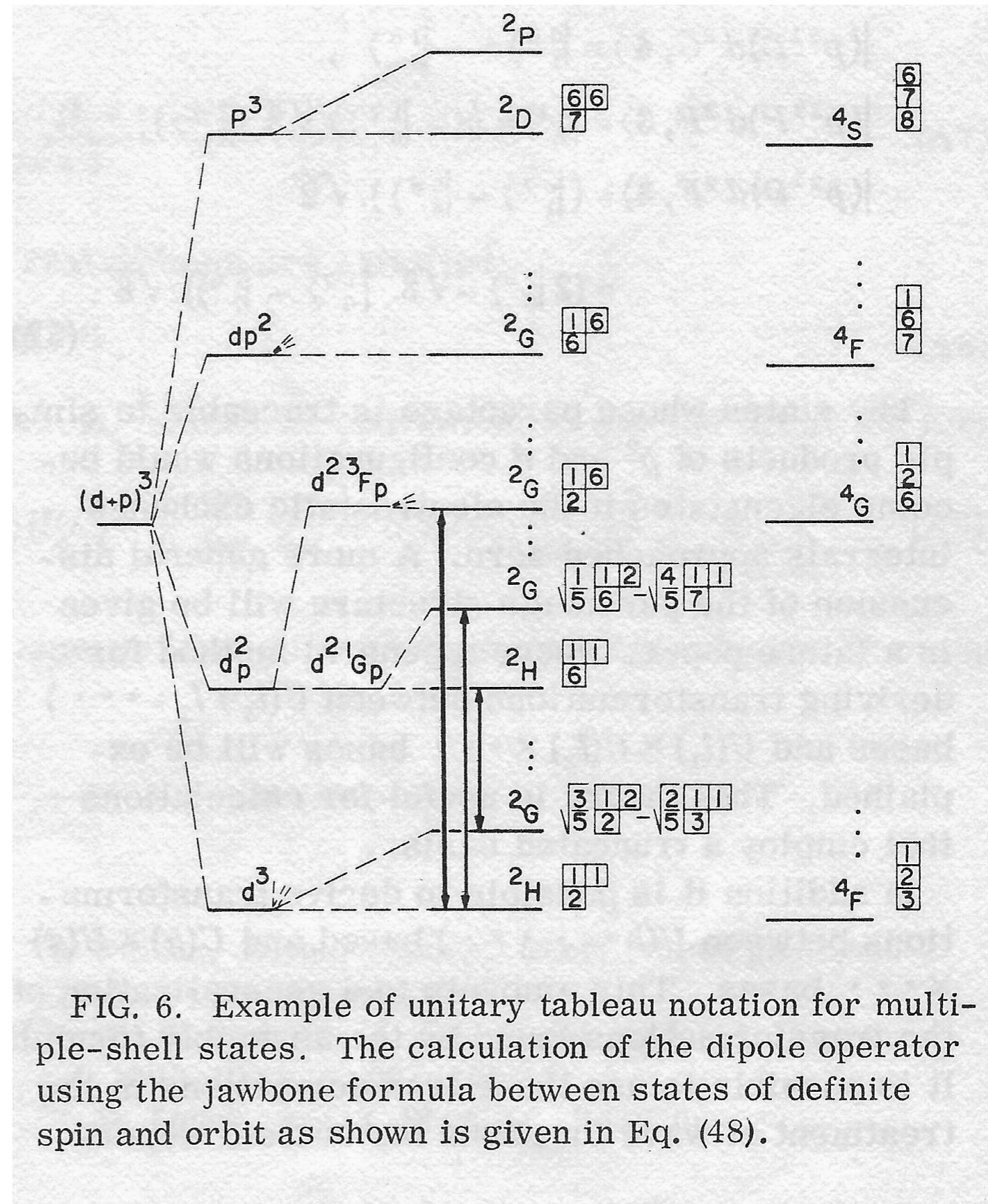
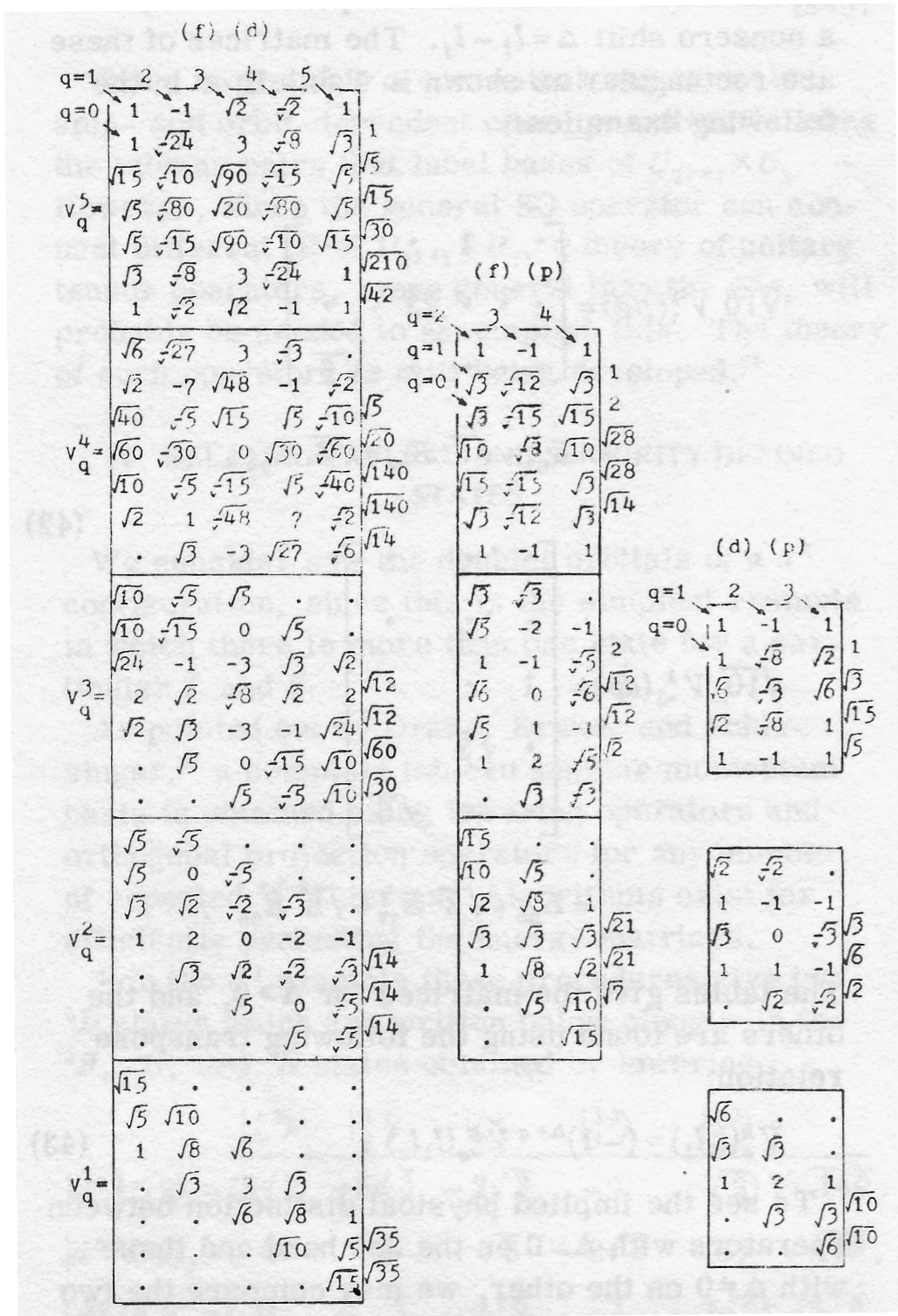
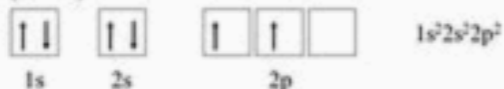

FIG. 6. Example of unitary tableau notation for multiple-shell states. The calculation of the dipole operator using the jawbone formula between states of definite spin and orbit as shown is given in Eq. (48).



The Aufbau Principal (cont.)

• Carbon (Z = 6)



Hund's Rule: Lowest energy configuration is the one in which the maximum number of unpaired electrons are distributed amongst a set of degenerate orbitals.

• Nitrogen (Z = 7)

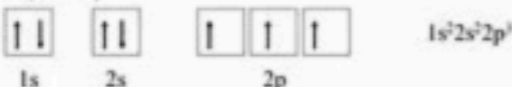

Hund's Rule

- Within a sublevel, place one electron per orbital before pairing them.
- "Empty Bus Seat Rule"



Hund's Rule and the Aufbau Principle

- **Aufbau principle** - when filling orbitals, start with the lowest energy and proceed to the next highest energy level.
- **Hund's rule** - within a subshell, electrons occupy the maximum number of orbitals possible.
- Electron configurations are sometimes depicted using boxes to represent orbitals. This depiction shows paired and unpaired electrons explicitly.

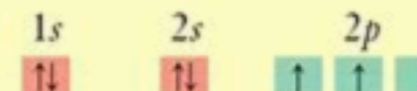

Hund's rule of maximum multiplicity

- The three rules are:
- For a given electron configuration, the term with maximum multiplicity has the lowest energy. The multiplicity is equal to $2S + 1$, where S is the total spin angular momentum for all electrons.
- For a given multiplicity, the term with the largest value of the total orbital angular momentum quantum number has the lowest energy.

Yay! (for the Googley internet)

Hund's Rule of maximum Multiplicity

- The above rules: not give idea abt filling the e- in to degenerate orbitals.
- For e.g., p-orbitals
- "when more than one orbitals of equal energies are available, then the e- will first occupy these orbitals separately with parallel spins. the pairing of e- will start only after all the orbitals of a given sub-level are singly occupied."
- Analogy: Students could fill each seat of a school bus, one person at a time, before doubling up.

Hund's Rule

In a set of orbitals, the electrons will fill the orbitals in a way that would give the maximum number of parallel spins (maximum number of unpaired electrons)

Analogy: Students could fill each seat of a school bus, one person at a time, before doubling up.

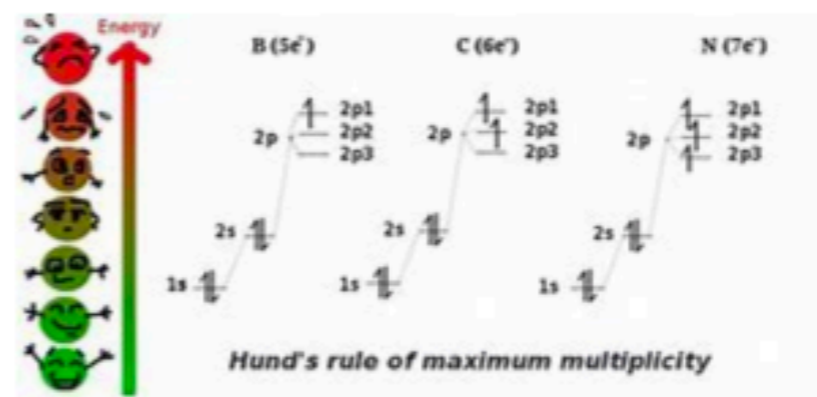
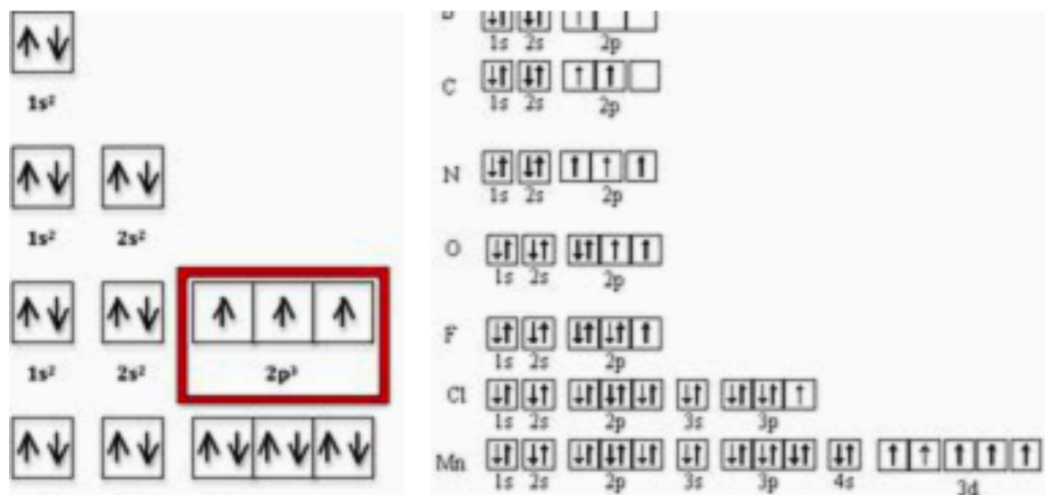

Complete set of E_{jk} matrix elements for the doublet (spin- $1/2$) p^3 orbits

	$ \frac{1}{2}^1\rangle$:	$ \frac{1}{2}^2\rangle$		$ \frac{1}{3}^1\rangle$:	$ \frac{1}{3}^2\rangle$		$ \frac{1}{2}^3\rangle$:	$ \frac{1}{3}^3\rangle$		$ \frac{2}{3}^2\rangle$:	$ \frac{2}{3}^3\rangle$
	$M = 2$		$M = 1$		$M = 0$		$M = -1$		$M = -1$		$M = -1$		$M = -1$		$M = -2$
$\langle \frac{1}{2}^1 $	$2^{(11)} + 1^{(22)}$		$1^{(12)}$		$1^{(23)}$		$-\sqrt{\frac{1}{2}}^{(13)}$		$\sqrt{\frac{3}{2}}^{(13)}$						
$\langle \frac{1}{2}^2 $			$1^{(11)} + 2^{(22)}$				$\sqrt{\frac{1}{2}}^{(23)}$		$\sqrt{\frac{3}{2}}^{(23)}$						$-1^{(13)}$
$\langle \frac{1}{3}^1 $					$2^{(11)} + 1^{(33)}$		$\sqrt{2}^{(12)}$								$1^{(13)}$
$\langle \frac{1}{3}^2 $							$1^{(11)} + 1^{(22)} + 1^{(33)}$						$\sqrt{\frac{1}{2}}^{(23)}$	$\sqrt{2}^{(12)}$	$\sqrt{\frac{1}{2}}^{(13)} = \langle E_{ij} \rangle$
$\langle \frac{1}{2}^3 $									$1^{(11)} + 1^{(22)} + 1^{(33)}$				$\sqrt{\frac{3}{2}}^{(23)}$		$\sqrt{\frac{3}{2}}^{(13)}$
$\langle \frac{1}{3}^3 $													$1^{(11)} + 2^{(33)}$		$1^{(12)}$
$\langle \frac{2}{3}^2 $														$2^{(22)} + 1^{(33)}$	$1^{(23)}$
$\langle \frac{2}{3}^3 $															$1^{(22)} + 2^{(33)}$

notation:
 (jk) numbers tell
 which E_{jk} gave that entry

Diagonal examples in n -particle notation:

$$\sqrt{3}\mathbf{V}_0^0 = E_{11} + E_{22} + E_{33}$$

$$\sqrt{2}\mathbf{V}_0^1 = E_{11} - E_{33} \equiv L_z$$

$$\sqrt{6}\mathbf{V}_0^2 = E_{11} - 2E_{22} + E_{33}$$

Off-Diagonal examples in n -particle notation:

$$\begin{aligned} \mathbf{V}_2^2 = E_{13} , \quad -2\mathbf{V}_1^2 = \sqrt{2}(E_{12} - E_{23}) , \quad 2\mathbf{V}_{-1}^2 = \sqrt{2}(E_{21} - E_{32}) , \quad 2\mathbf{V}_{-2}^2 = E_{31} , \\ -2\mathbf{V}_1^1 = \sqrt{2}(E_{12} + E_{23}) \equiv L_+ , \quad 2\mathbf{V}_{-1}^1 = \sqrt{2}(E_{21} + E_{32}) \equiv L_- . \end{aligned}$$

Tableau calculation of 3-electron $\ell=1$ orbital p^3 -states and their V^k_q matrices

Start with highest angular momentum ($L=2$) p^3 state: $|^2D_{M=2}^{L=2}\rangle = \begin{array}{|c|c|} \hline 1 & 1 \\ \hline 2 & \\ \hline \end{array}$ (Fermi spin-mate $\begin{array}{|c|c|} \hline \uparrow & \uparrow \\ \hline \downarrow & \\ \hline \end{array}$)

Then apply lowering operator $L_- \equiv \sqrt{2}(E_{21} + E_{32})$ $|^2D_{M=1}^{L=2}\rangle = \frac{1}{2}L_-|^2D_{M=2}^{L=2}\rangle = \frac{1}{2}\sqrt{2}(E_{21} + E_{32}) \begin{array}{|c|c|} \hline 1 & 1 \\ \hline 2 & \\ \hline \end{array}$

Here this is done using Tableau "Jawbone" formula. $= \frac{1}{\sqrt{2}} \left(\begin{array}{|c|c|} \hline 1 & 2 \\ \hline 2 & \\ \hline \end{array} + \begin{array}{|c|c|} \hline 1 & 1 \\ \hline 3 & \\ \hline \end{array} \right)$

Orthogonal to this is a 2P ($M=1$) state

$$|^2P_{M=1}^{L=1}\rangle = \frac{1}{\sqrt{2}} \left(\begin{array}{|c|c|} \hline 1 & 2 \\ \hline 2 & \\ \hline \end{array} - \begin{array}{|c|c|} \hline 1 & 1 \\ \hline 3 & \\ \hline \end{array} \right)$$

Next we calculate 2^n -pole moments the pair:

$$\begin{aligned} \langle ^2P_{M=1}^{L=1} | V_0^k | ^2D_{M=1}^{L=2} \rangle &= \\ \frac{1}{\sqrt{2}} \left(\begin{array}{|c|c|} \hline 1 & 2 \\ \hline 2 & \\ \hline \end{array} + \begin{array}{|c|c|} \hline 1 & 1 \\ \hline 3 & \\ \hline \end{array} \right) \left[\binom{k}{11} E_{11} + \binom{k}{22} E_{22} + \binom{k}{33} E_{33} \right] \left(\begin{array}{|c|c|} \hline 1 & 2 \\ \hline 2 & \\ \hline \end{array} - \begin{array}{|c|c|} \hline 1 & 1 \\ \hline 3 & \\ \hline \end{array} \right) \\ &= \frac{1}{2} \left[-\binom{2}{11} E_{11} + 2\binom{2}{22} E_{22} - \binom{2}{33} \right] = -\sqrt{\frac{3}{2}} \quad \text{for : } k=2 \\ &= \frac{1}{2} \left[-\binom{1}{11} E_{11} + 2\binom{1}{22} E_{22} - \binom{1}{33} \right] = 0 \quad \text{for : } k=1 \\ &= \frac{1}{2} \left[-\binom{0}{11} E_{11} + 2\binom{0}{22} E_{22} - \binom{0}{33} \right] = 0 \quad \text{for : } k=0 \end{aligned}$$

(a) $\langle T | E_{ii} | T \rangle = \delta_{T,T} (\text{number of } i\text{'s})$ (b) $\langle T | E_{ij} | T \rangle = \langle T | E_{ji} | T \rangle$

(c) $\begin{array}{|c|} \hline i-1 \\ \hline i \\ \hline \end{array} \begin{array}{|c|} \hline i \\ \hline i-1 \\ \hline \end{array} \xrightarrow{E_{i-1,i}} \begin{array}{|c|} \hline i \\ \hline i \\ \hline \end{array} = \sqrt{\frac{d+1}{d}} \begin{array}{|c|} \hline i \\ \hline i-1 \\ \hline \end{array} \begin{array}{|c|} \hline i \\ \hline i \\ \hline \end{array}$

(d) $\begin{array}{|c|} \hline i \\ \hline i-1 \\ \hline \end{array} \begin{array}{|c|} \hline i \\ \hline i \\ \hline \end{array} \xrightarrow{E_{i-1,i}} \begin{array}{|c|} \hline i-1 \\ \hline i \\ \hline \end{array} = \sqrt{\frac{d-1}{d}} \begin{array}{|c|} \hline i-1 \\ \hline i-1 \\ \hline \end{array} \begin{array}{|c|} \hline i \\ \hline i \\ \hline \end{array}$

(e) $E_{23} \begin{array}{|c|c|} \hline 1 & 3 \\ \hline 3 & \\ \hline \end{array} = \frac{1}{\sqrt{2}} \begin{array}{|c|c|} \hline 1 & 2 \\ \hline 3 & \\ \hline \end{array} + \frac{1}{\sqrt{2}} \begin{array}{|c|c|} \hline 1 & 3 \\ \hline 2 & \\ \hline \end{array}$

(f) $E_{12} \begin{array}{|c|c|} \hline 1 & 2 \\ \hline 1 & \\ \hline \end{array} = \sqrt{2} \begin{array}{|c|c|} \hline 1 & 1 \\ \hline 1 & \\ \hline \end{array}$

(g) $\begin{array}{|c|} \hline i-1 \\ \hline i \\ \hline \end{array} \begin{array}{|c|} \hline i \\ \hline i \\ \hline \end{array} \xrightarrow{E_{i-1,i}} \begin{array}{|c|} \hline i-1 \\ \hline i-1 \\ \hline \end{array} = 1 \begin{array}{|c|} \hline i-1 \\ \hline i \\ \hline \end{array} \begin{array}{|c|} \hline i \\ \hline i \\ \hline \end{array}$

(h) $\begin{array}{|c|} \hline i-1 \\ \hline i \\ \hline \end{array} \begin{array}{|c|} \hline i \\ \hline i-1 \\ \hline \end{array} \xrightarrow{E_{i-1,i}} \begin{array}{|c|} \hline i-1 \\ \hline i-1 \\ \hline \end{array} = 1 \begin{array}{|c|} \hline i-1 \\ \hline i-1 \\ \hline \end{array} \begin{array}{|c|} \hline i \\ \hline i \\ \hline \end{array}$

$$|1,2,3\rangle \equiv |1\rangle_{\text{particle-a}} |2\rangle_{\text{particle-b}} |3\rangle_{\text{particle-c}} \equiv |1\rangle_a |2\rangle_b |3\rangle_c$$

Single particle p^1 -orbitals: $U(3)$ triplet $|p^1 \square\rangle$

$$e_{11} = \begin{pmatrix} 1 & \cdot & \cdot \\ \cdot & \cdot & \cdot \\ \cdot & \cdot & \cdot \end{pmatrix}, e_{12} = \begin{pmatrix} \cdot & 1 & \cdot \\ \cdot & \cdot & \cdot \\ \cdot & \cdot & \cdot \end{pmatrix}, e_{13} = \begin{pmatrix} \cdot & \cdot & 1 \\ \cdot & \cdot & \cdot \\ \cdot & \cdot & \cdot \end{pmatrix}, e_{21} = \begin{pmatrix} \cdot & \cdot & \cdot \\ 1 & \cdot & \cdot \\ \cdot & \cdot & \cdot \end{pmatrix}, \dots e_{33} = \begin{pmatrix} \cdot & \cdot & \cdot \\ \cdot & \cdot & \cdot \\ 1 & \cdot & \cdot \end{pmatrix}.$$

$$\begin{aligned} e_{12}e_{21} &= e_{11} & |1\rangle\langle 2||2\rangle\langle 1| &= |1\rangle\langle 1| \\ e_{12}e_{22} &= e_{12} & |1\rangle\langle 2||2\rangle\langle 2| &= |1\rangle\langle 2| \\ & & \vdots & \\ e_{jk}e_{pq} &= \delta_{pk}e_{jq} & |j\rangle\langle k||p\rangle\langle q| &= \delta_{pk}|j\rangle\langle q| \end{aligned}$$

Elementary matrix algebra

General elementary operator commutation $[E_{jk}, E_{pq}] = \delta_{kp}E_{jq} - \delta_{qj}E_{pk}$
has same form as 1-particle commutation: $[e_{jk}, e_{pq}] = \delta_{kp}e_{jq} - \delta_{qj}e_{pk}$

*Elementary-elementary
operator commutation algebra*

This applies to all of multi-particle representations of E_{jk} and to momentum operators L_x , L_y , and L_z .

Single particle p -orbit ($\ell=1$) representation of L_x , L_y , and L_z

$$D_{mn}^1(L_x) = \frac{1}{\sqrt{2}} \begin{pmatrix} \cdot & 1 & \cdot \\ 1 & \cdot & 1 \\ \cdot & 1 & \cdot \end{pmatrix}, \quad D_{mn}^1(L_y) = \frac{-i}{\sqrt{2}} \begin{pmatrix} \cdot & 1 & \cdot \\ -1 & \cdot & 1 \\ \cdot & -1 & \cdot \end{pmatrix}, \quad D_{mn}^1(L_z) = \begin{pmatrix} 1 & \cdot & \cdot \\ \cdot & 0 & \cdot \\ \cdot & \cdot & -1 \end{pmatrix}$$

Elementary operator form of L_x , L_y , and L_z

$$L_x = (E_{12} + E_{23} + E_{21} + E_{32}) / \sqrt{2}, \quad L_y = -i(E_{12} + E_{23} - E_{21} - E_{32}) / \sqrt{2}, \quad L_z = E_{11} - E_{33}$$

...and of raise-lower operators L_+ and L_- .

$$L_+ = L_x + iL_y = \sqrt{2}(E_{12} + E_{23}), \quad L_- = L_x - iL_y = \sqrt{2}(E_{21} + E_{32}) = L_+^\dagger, \quad L_z = [L_+, L_-]$$